

STANLEY®

BR45 HYDRAULIC BREAKER



USER MANUAL Safety, Operation and Maintenance



© 2014 Stanley Black & Decker, Inc.
New Britain, CT 06053
U.S.A.
62388 2/2015 Ver 7

DECLARATION OF CONFORMITY

DECLARATION OF CONFORMITY
 ÜBEREINSTIMMUNGS-ERKLÄRUNG
 DECLARATION DE CONFORMITE CEE
 DECLARACION DE CONFORMIDAD
 DICHIARAZIONE DI CONFORMITA



I, the undersigned:
 Ich, der Unterzeichnende:
 Je soussigné:
 El abajo firmante:
 Io sottoscritto:

Weisbeck, Andy

Surname and First names/Familiennamen und Vornamen/Nom et prénom/Nombre y apellido/Cognome e nome

hereby declare that the equipment specified hereunder:
 bestätige hiermit, daß erklaren Produkt genannten Werk oder Gerät:
 déclare que l'équipement visé ci-dessous:
 Por la presente declaro que el equipo se especifica a continuación:
 Dichiaro che le apparecchiature specificate di seguito:

- Category: **Hydraulic Hand Held Concrete Breaker**
 Kategorie:
 Catégorie:
 Categoría:
 Categoria:
- Make/Marke/Marque/Marca/Marca **Stanley**
- Type/Typ/Type/Tipo/Tipo: **BR4514801, BR4516801, BR45350, BR4516807, BR4516807A
BR4514801A**
- Serial number of equipment:
 Seriennummer des Geräts:
 Numéro de série de l'équipement:
 Numero de serie del equipo:
 Matricola dell'attrezzatura:

BR4514801	All
BR4514801A	All
BR4516801	All
BR4516807	All
BR4516807A	All
BR45350	Serial # 030612029 and above

5. Mass/Masse/Masse/Masa/Massa 23 kg
Has been manufactured in conformity with
Wurde hergestellt in Übereinstimmung mit
Est fabriqué conformément
Ha sido fabricado de acuerdo con
E' stata costruita in conformità con

Directive/Standards Richtlinie/Standards Directives/Normes Directriz/Los Normas Direttiva/Norme	No. Nr Numéro No n.	Approved body Prüfung durch Organisme agréé Aprobado Collaudato
ISO Noise Directive	11148-4:2010 2000/14/EC:2005	Self AkustikNet (Notified body ID 1585) Bagsvard Hovedgade 141, 2880 Bagsvard, Denmark Certificate #863/2011/002
Machinery Directive ISO	2006/42/EC:2006 28927-10:2011	Self Self

- Special Provisions: **None**
 Spezielle Bestimmungen:
 Dispositions particulières:
 Provisiones especiales:
 Disposizioni speciali:
- Measurements: **Measured Sound Power Level 105 LwA**
Guaranteed Sound Power Level 107 LwA
 Measured in accordance to Directive 2000/14/EC,
 Annex III, Part B, No 10, 15 kg<m< 30 kg
 Messungen
 Mesures
 Mediciones
 Misurazioni

8. Representative in the Union: **Patrick Vervier, Stanley Dubuis 17-19, rue Jules Berthonneau-BP 3406 41034 Blois Cedex, France.**
 Vertreter in der Union/Représentant dans l'union/Representante en la Union/Rappresentante presso l'Unione

Done at/Ort/Fait à/Dado en/Fatto a Stanley Hydraulic Tools, Milwaukie, Oregon USA Date/Datum/le/Fecha/Data 1-30-12

Signature/Unterschrift/Signature/Firma/Firma 
 Position/Position/Fonction/Cargo/Posizione Director of Product Development

TABLE OF CONTENTS

DECLARATION OF CONFORMITY	2
SAFETY SYMBOLS	4
SAFETY PRECAUTIONS.....	5
TOOL STICKERS & TAGS	7
HOSE TYPES.....	8
HOSE RECOMMENDATIONS	9
FIGURE 1. TYPICAL HOSE CONNECTIONS	9
HTMA REQUIREMENTS.....	10
OPERATION.....	11
TOOL PROTECTION & CARE	12
TROUBLESHOOTING	13
CHARGING THE ACCUMULATOR.....	14
FIGURE 2. CHARGING THE ACCUMULATOR.....	15
UNDERWATER TOOLS DEPTH GUIDELINE.....	16
SPECIFICATIONS.....	17
ACCESSORIES.....	18
BR45 T-HANDLE PARTS ILLUSTRATION.....	19
BR45 T-HANDLE PARTS LIST.....	20
BR45 ANTI-VIBRATION HANDLE PARTS ILLUSTRATION	21
BR45 ANTI-VIBRATION HANDLE PARTS LIST	22
BREAKER FOOT ASSEMBLIES.....	23 THRU 27

IMPORTANT

To fill out a Product Warranty Validation form, and for information on your warranty, visit Stanleyhydraulics.com and select the Company tab, Warranty.
(NOTE: The warranty Validation record must be submitted to validate the warranty).

SERVICING: This manual contains safety, operation, and routine maintenance instructions. Stanley Hydraulic Tools recommends that servicing of hydraulic tools, other than routine maintenance, must be performed by an authorized and certified dealer. Please read the following warning.

⚠ WARNING

SERIOUS INJURY OR DEATH COULD RESULT FROM THE IMPROPER REPAIR OR SERVICE OF THIS TOOL.

REPAIRS AND / OR SERVICE TO THIS TOOL MUST ONLY BE DONE BY AN AUTHORIZED AND CERTIFIED DEALER.

For the nearest authorized and certified dealer, call Stanley Hydraulic Tools at the number listed on the back of this manual and ask for a Customer Service Representative.

SAFETY PRECAUTIONS

Tool operators and maintenance personnel must always comply with the safety precautions given in this manual and on the stickers and tags attached to the tool and hose.

These safety precautions are given for your safety. Review them carefully before operating the tool and before performing general maintenance or repairs.

Supervising personnel should develop additional precautions relating to the specific work area and local safety regulations. If so, place the added precautions in the space provided in this manual.

The BR45 Hydraulic Breaker will provide safe and dependable service if operated in accordance with the instructions given in this manual. Read and understand this manual and any stickers and tags attached to the tool and hoses before operation. Failure to do so could result in personal injury or equipment damage.



- Operator must start in a work area without bystanders. The operator must be familiar with all prohibited work areas such as excessive slopes and dangerous terrain conditions.
- Establish a training program for all operators to ensure safe operation.
- Do not operate the tool unless thoroughly trained or under the supervision of an instructor.
- Always wear safety equipment such as goggles, gloves, ear, head, and breathing protection, and safety shoes at all times when operating the tool.
- Do not inspect, carry or clean the tool while the hydraulic power source is connected. Accidental engagement of the tool can cause serious injury.
- Supply hoses must have a minimum working pressure rating of 2500 psi/175 bar.
- Be sure all hose connections are tight.
- The hydraulic circuit control valve must be in the "OFF" position when coupling or uncoupling the tool. Wipe all couplers clean before connecting. Use only lint-free cloths. Failure to do so may result in damage to the quick couplers and cause overheating of the hydraulic system.
- Do not operate the tool at oil temperatures above 140 °F/60 °C. Operation at higher oil temperatures can cause operator discomfort and may damage the tool. Never come in contact with the tool bit, the bit can get hot.
- Do not operate a damaged, improperly adjusted, or incompletely assembled tool.
- Do not weld, cut with an acetylene torch, or hard-face the tool bit.
- To avoid personal injury or equipment damage, all tool repair, maintenance and service must only be performed by authorized and properly trained personnel.
- Do not exceed the rated limits of the tool or use the tool for applications beyond its design capacity.
- Always keep critical tool markings, such as labels and warning stickers legible.
- Always replace parts with replacement parts recommended by Stanley Hydraulic Tools.
- Check fastener tightness often and before each use daily.
- Never operate the tool if you cannot be sure that underground utilities are not present.
- Do not wear loose fitting clothing when operating the tool.
- **Warning:** Use of this tool on certain materials during demolition could generate dust potentially containing a variety of hazardous substances such as asbestos, silica or lead. Inhalation of dust containing these or other hazardous substances could result in serious injury, cancer or death. Protect yourself and those around you. Research and understand the materials you are cutting. Follow correct safety procedures and comply with all applicable national, state or provisional health and safety regulations relating to them, including, if appropriate arranging for the safe disposal of the materials by a qualified person.

SAFETY PRECAUTIONS

- **Warning:** Hydraulic fluid under pressure could cause skin injection injury. If you are injured by hydraulic fluid, get medical attention immediately.
- Keep all body parts away from the working tool.
- When handling material or the tool bit, wear your (PPE) Personal Protection Equipment.
- Be observant of the hydraulic hoses lying about the work area, they can be a tripping hazard.
- Always de-energize the hydraulic system when changing a tool bit.
- Take caution when changing a tool bit, tool bits can get very hot.
- Never use the tool in an explosive atmosphere, sparks from the breaking process could ignite explosive gas.
- Use proper lifting techniques when handling the tool, get help from a co-worker and do not over-reach.
- Use proper protection from falling or flying debris, keep bystanders at a safe distance.
- Do not exceed the rated flow and pressure. See Specifications in this manual for correct flow rate and pressure rating. Rapid failure of the internal seals may result.

TOOL STICKERS & TAGS

Please refer to the Parts Illustration for location of stickers.

STANLEY
3810 S.E. Naef Road
Milwaukie, Oregon 97267 U.S.A. 72921

BR45 BREAKER

WEIGHT: 51lb/23kg
FLOW: 4-6gpm/15-23lpm
MAX PRESS: 2500psi/172bar
NOM PRESS: 1500psi/103bar
ACCUMULATOR CHARGE: 600psi/41bar NITROGEN

72921 5-gpm T-Handle Sticker

STANLEY
3810 S.E. Naef Road
Milwaukie, Oregon 97267 U.S.A. 72920

BR45 BREAKER

WEIGHT: 55lb/25kg
FLOW: 4-6gpm/15-23lpm
MAX PRESS: 2500psi/172bar
NOM PRESS: 1500psi/103bar
ACCUMULATOR CHARGE: 600psi/41bar NITROGEN

72920 5-gpm Anti-Vib Sticker



58601 Sound Level Sticker (CE Only)



11207 Circuit Type C Sticker (CE Only)



28322 CE Sticker (CE Only)

STANLEY
3810 S.E. Naef Road
Milwaukie, Oregon 97267 U.S.A. 72928

BR45 BREAKER

WEIGHT: 51lb/23kg
FLOW: 7-9gpm/26-34lpm
MAX PRESS: 2500psi/172bar
NOM PRESS: 1500psi/103bar
ACCUMULATOR CHARGE: 600psi/41bar NITROGEN

72928 8-gpm T-Handle Sticker

STANLEY
3810 S.E. Naef Road
Milwaukie, Oregon 97267 U.S.A. 72927

BR45 BREAKER

WEIGHT: 55lb/25kg
FLOW: 7-9gpm/26-34lpm
MAX PRESS: 2500psi/172bar
NOM PRESS: 1500psi/103bar
ACCUMULATOR CHARGE: 600psi/41bar NITROGEN

72927 8-gpm Anti-Vib Sticker



28409 Composite Sticker (CE Only)

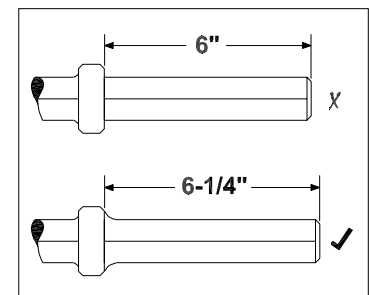

11208 Hex Shank Length Sticker



10180 Caution Sticker

The safety tag (P/N 15875) at right is attached to the tool when shipped from the factory. Read and understand the safety instructions listed on this tag before removal. We suggest you retain this tag and attach it to the tool when not in use.

DANGER

- FAILURE TO USE HYDRAULIC HOSE LABELED AND CERTIFIED AS NON-CONDUCTIVE WHEN USING HYDRAULIC TOOLS ON OR NEAR ELECTRICAL LINES MAY RESULT IN DEATH OR SERIOUS INJURY.
BEFORE USING HOSE LABELED AND CERTIFIED AS NON-CONDUCTIVE ON OR NEAR ELECTRICAL LINES BE SURE THE HOSE IS MAINTAINED AS NON-CONDUCTIVE. THE HOSE SHOULD BE REGULARLY TESTED FOR ELECTRIC CURRENT LEAKAGE IN ACCORDANCE WITH YOUR SAFETY DEPARTMENT INSTRUCTIONS.
- A HYDRAULIC LEAK OR BURST MAY CAUSE OIL INJECTION INTO THE BODY OR CAUSE OTHER SEVERE PERSONAL INJURY.
 - DO NOT EXCEED SPECIFIED FLOW AND PRESSURE FOR THIS TOOL. EXCESS FLOW OR PRESSURE MAY CAUSE A LEAK OR BURST.
 - DO NOT EXCEED RATED WORKING PRESSURE OF HYDRAULIC HOSE USED WITH THIS TOOL. EXCESS PRESSURE MAY CAUSE A LEAK OR BURST.
 - CHECK TOOL HOSE COUPLERS AND CONNECTORS DAILY FOR LEAKS. DO NOT FEEL FOR LEAKS WITH YOUR HANDS. CONTACT WITH A LEAK MAY RESULT IN SEVERE PERSONAL INJURY.

IMPORTANT

READ OPERATION MANUAL AND SAFETY INSTRUCTIONS FOR THIS TOOL BEFORE USING IT.

USE ONLY PARTS AND REPAIR PROCEDURES APPROVED BY STANLEY AND DESCRIBED IN THE OPERATION MANUAL.

TAG TO BE REMOVED ONLY BY TOOL OPERATOR.

SEE OTHER SIDE

DANGER

- DO NOT LIFT OR CARRY TOOL BY THE HOSES. DO NOT ABUSE HOSE. DO NOT USE KINKED, TORN OR DAMAGED HOSE.
- MAKE SURE HYDRAULIC HOSES ARE PROPERLY CONNECTED TO THE TOOL BEFORE PRESSURING SYSTEM. SYSTEM PRESSURE HOSE MUST ALWAYS BE CONNECTED TO TOOL "IN" PORT. SYSTEM RETURN HOSE MUST ALWAYS BE CONNECTED TO TOOL "OUT" PORT. REVERSING CONNECTIONS MAY CAUSE REVERSE TOOL OPERATION WHICH CAN RESULT IN SEVERE PERSONAL INJURY.
- DO NOT CONNECT OPEN-CENTER TOOLS TO CLOSED-CENTER HYDRAULIC SYSTEMS. THIS MAY RESULT IN LOSS OF OTHER HYDRAULIC FUNCTIONS POWERED BY THE SAME SYSTEM AND/OR SEVERE PERSONAL INJURY.
- BYSTANDERS MAY BE INJURED IN YOUR WORK AREA. KEEP BYSTANDERS CLEAR OF YOUR WORK AREA.
- WEAR HEARING, EYE, FOOT, HAND AND HEAD PROTECTION.
- TO AVOID PERSONAL INJURY OR EQUIPMENT DAMAGE, ALL TOOL REPAIR MAINTENANCE AND SERVICE MUST ONLY BE PERFORMED BY AUTHORIZED AND PROPERLY TRAINED PERSONNEL.

IMPORTANT

READ OPERATION MANUAL AND SAFETY INSTRUCTIONS FOR THIS TOOL BEFORE USING IT.

USE ONLY PARTS AND REPAIR PROCEDURES APPROVED BY STANLEY AND DESCRIBED IN THE OPERATION MANUAL.

TAG TO BE REMOVED ONLY BY TOOL OPERATOR.

SEE OTHER SIDE

SAFETY TAG P/N 15875 (Shown smaller than actual size)

HOSE TYPES

The rated working pressure of the hydraulic hose must be equal to or higher than the relief valve setting on the hydraulic system. There are three types of hydraulic hose that meet this requirement and are authorized for use with Stanley Hydraulic Tools. They are:

Certified non-conductive — constructed of thermoplastic or synthetic rubber inner tube, synthetic fiber braid reinforcement, and weather resistant thermoplastic or synthetic rubber cover. *Hose labeled **certified non-conductive** is the only hose authorized for use near electrical conductors.*

Wire-braided (conductive) — constructed of synthetic rubber inner tube, single or double wire braid reinforcement, and weather resistant synthetic rubber cover. *This hose is **conductive** and must never be used near electrical conductors.*

Fabric-braided (not certified or labeled non-conductive) — constructed of thermoplastic or synthetic rubber inner tube, synthetic fiber braid reinforcement, and weather resistant thermoplastic or synthetic rubber cover. *This hose is **not certified non-conductive** and must never be used near electrical conductors.*

HOSE SAFETY TAGS

To help ensure your safety, the following DANGER tags are attached to all hose purchased from Stanley Hydraulic Tools. DO NOT REMOVE THESE TAGS.

If the information on a tag is illegible because of wear or damage, replace the tag immediately. A new tag may be obtained from your Stanley Distributor.

THE TAG SHOWN BELOW IS ATTACHED TO “CERTIFIED NON-CONDUCTIVE” HOSE

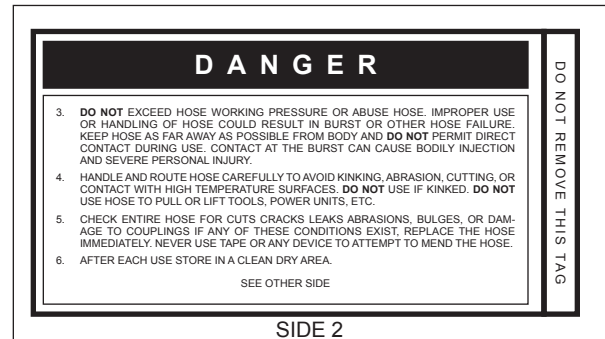
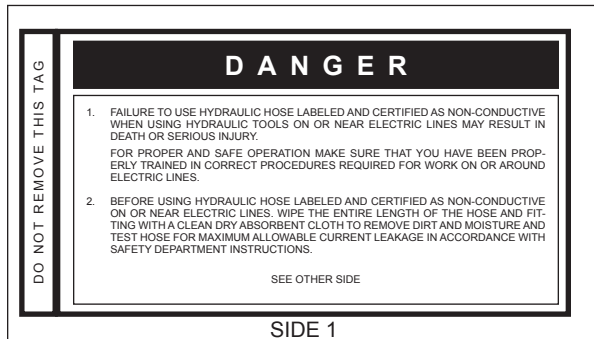

(Shown smaller than actual size)

THE TAG SHOWN BELOW IS ATTACHED TO “CONDUCTIVE” HOSE.

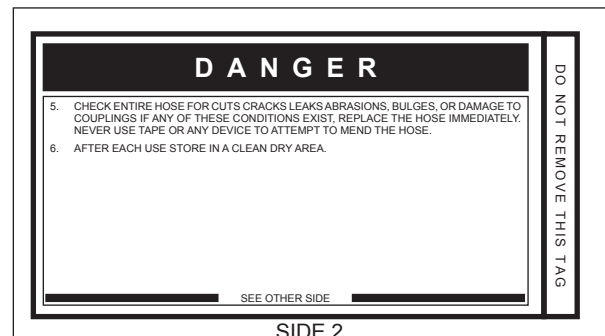
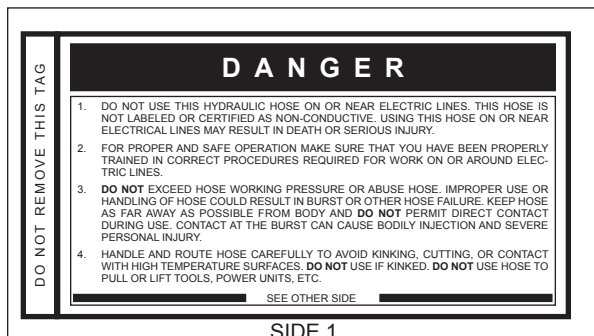

(Shown smaller than actual size)

HOSE RECOMMENDATIONS

Tool to Hydraulic Circuit Hose Recommendations

The chart to the right shows recommended minimum hose diameters for various hose lengths based on gallons per minute (gpm)/liters per minute (lpm). These recommendations are intended to keep return line pressure (back pressure) to a minimum acceptable level to ensure maximum tool performance.

This chart is intended to be used for hydraulic tool applications only based on Stanley Hydraulic Tools tool operating requirements and should not be used for any other applications.

All hydraulic hose must have at least a rated minimum working pressure equal to the maximum hydraulic system relief valve setting.

All hydraulic hose must meet or exceed specifications as set forth by SAE J517.

Oil Flow		Hose Lengths		Inside Diameter		USE (Press/Return)	Min. Working Pressure	
GPM	LPM	FEET	METERS	INCH	MM		PSI	BAR
Certified Non-Conductive Hose - Fiber Braid - for Utility Bucket Trucks								
4-9	15-34	up to 10	up to 3	3/8	10	Both	2250	155
Conductive Hose - Wire Braid or Fiber Braid -DO NOT USE NEAR ELECTRICAL CONDUCTORS								
4-6	15-23	up to 25	up to 7.5	3/8	10	Both	2500	175
4-6	15-23	26-100	7.5-30	1/2	13	Both	2500	175
5-10.5	19-40	up to 50	up to 15	1/2	13	Both	2500	175
5-10.5	19-40	51-100	15-30	5/8	16	Both	2500	175
5-10.5	19-40	100-300	30-90	5/8	16	Pressure	2500	175
10-13	38-49	up to 50	up to 15	3/4	19	Return	2500	175
10-13	38-49	51-100	15-30	5/8	16	Both	2500	175
10-13	38-49	100-200	30-60	3/4	19	Pressure	2500	175
13-16	49-60	up to 25	up to 8	1	25.4	Return	2500	175
13-16	49-60	26-100	8-30	5/8	16	Pressure	2500	175
				3/4	19	Return	2500	175
				3/4	19	Pressure	2500	175
				1	25.4	Return	2500	175

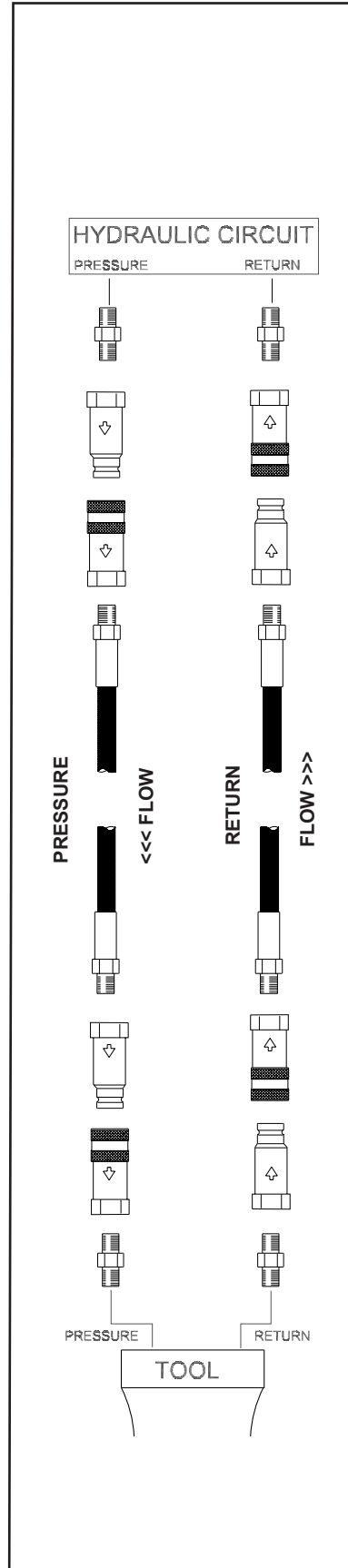

Figure 1. Typical Hose Connections

HTMA / EHTMA REQUIREMENTS

HTMA / EHTMA REQUIREMENTS

HTMA

HYDRAULIC SYSTEM REQUIREMENTS

TOOL TYPE

TYPE I

TYPE II

TYPE RR

TYPE III

Flow Range	4-6 gpm (15-23 lpm)	7-9 gpm (26-34 lpm)	9-10.5 gpm (34-40 lpm)	11-13 gpm (42-49 lpm)
Nominal Operating Pressure (at the power supply outlet)	1500 psi (103 bar)	1500 psi (103 bar)	1500 psi (103 bar)	1500 psi (103 bar)
System relief valve setting (at the power supply outlet)	2100-2250 psi (145-155 bar)	2100-2250 psi (145-155 bar)	2200-2300 psi (152-159 bar)	2100-2250 psi (145-155 bar)
Maximum back pressure (at tool end of the return hose)	250 psi (17 bar)	250 psi (17 bar)	250 psi (17 bar)	250 psi (17 bar)
Measured at a max. fluid viscosity of: (at min. operating temperature)	400 ssu* (82 centistokes)	400 ssu* (82 centistokes)	400 ssu* (82 centistokes)	400 ssu* (82 centistokes)
Temperature: Sufficient heat rejection capacity to limit max. fluid temperature to: (at max. expected ambient temperature)	140° F (60° C)	140° F (60° C)	140° F (60° C)	140° F (60° C)
Min. cooling capacity at a temperature difference of between ambient and fluid temps	3 hp (2.24 kW) 40° F (22° C)	5 hp (3.73 kW) 40° F (22° C)	6 hp (5.22 kW) 40° F (22° C)	7 hp (4.47 kW) 40° F (22° C)
NOTE: Do not operate the tool at oil temperatures above 140° F (60° C). Operation at higher temperatures can cause operator discomfort at the tool.				
Filter Min. full-flow filtration Sized for flow of at least: (For cold temp. startup and max. dirt-holding capacity)	25 microns 30 gpm (114 lpm)	25 microns 30 gpm (114 lpm)	25 microns 30 gpm (114 lpm)	25 microns 30 gpm (114 lpm)
Hydraulic fluid Petroleum based (premium grade, anti-wear, non-conductive) Viscosity (at min. and max. operating temps)	100-400 ssu*	100-400 ssu* (20-82 centistokes)	100-400 ssu*	100-400 ssu*
NOTE: When choosing hydraulic fluid, the expected oil temperature extremes that will be experienced in service determine the most suitable temperature viscosity characteristics. Hydraulic fluids with a viscosity index over 140 will meet the requirements over a wide range of operating temperatures.				
*SSU = Saybolt Seconds Universal				

EHTMA HYDRAULIC SYSTEM REQUIREMENTS

CLASSIFICATION



Flow Range	3.5-4.3 gpm (13.5-16.5 lpm)	4.7-5.8 gpm (18-22 lpm)	7.1-8.7 gpm (27-33 lpm)	9.5-11.6 gpm (36-44 lpm)	11.8-14.5 gpm (45-55 lpm)
Nominal Operating Pressure (at the power supply outlet)	1870 psi (129 bar)	1500 psi (103 bar)	1500 psi (103 bar)	1500 psi (103 bar)	1500 psi (103 bar)
System relief valve setting (at the power supply outlet)	2495 psi (172 bar)	2000 psi (138 bar)	2000 psi (138 bar)	2000 psi (138 bar)	2000 psi (138 bar)

NOTE: These are general hydraulic system requirements. See tool specification page for tool specific requirements

OPERATION

The recommended hose size is .500 inch/12 mm I.D. up to 50 ft/15 m long and .625 inch/16 mm I.D. minimum up to 100 ft/30 m.

PRE-OPERATION PROCEDURES

CHECK POWER SOURCE

1. Using a calibrated flowmeter and pressure gauge, check that the hydraulic power source develops a flow of 7–9 gpm/26–34 lpm at 1500–2000 psi/105–140 bar or 5–6 gpm /18–22 lpm at 1500–2000 psi /105–140 bar.
2. Make certain the hydraulic power source is equipped with a relief valve set to open at 2250 psi/155 bar maximum.

INSTALL TOOL BIT

1. Rotate the latch on the breaker foot downward (pointing away from the tool).
2. Insert the tool bit into the foot and pull the latch up to lock the tool bit in place.

CONNECT HOSES

1. Wipe all hose couplers with a clean, lint-free cloth before making connections.
2. Connect the hoses from the hydraulic power source to the tool fittings or quick disconnects. It is a good practice to connect return hoses first and disconnect them last to minimize or avoid trapped pressure within the tool.
3. Observe flow indicators stamped on hose couplers to ensure that fluid flow is in the proper direction. The female coupler on the tool hose is the inlet coupler.
4. Move the hydraulic circuit control valve to the ON position to operate the tool.

NOTE:

If uncoupled hoses are left in the sun, pressure increase within the hoses may make them difficult to connect. When possible, connect the free ends of the hoses together.

OPERATION PROCEDURES

1. Observe all safety precautions.
2. Install the appropriate tool bit for the job.
3. Place the bit firmly on the surface to be broken.
4. Squeeze the trigger to start the breaker. Adequate down pressure is very important. When the tool bit breaks through the obstruction or becomes bound,

release the trigger and reposition the tool bit.

NOTE:

Partially depressing the trigger allows the tool to run at slow speed. Slow-speed operation permits easier starting of the tool bit into the work surface.

5. To start, break an opening (hole) in the center of the surface. After making a hole, break portions of the material into the original opening. For best productivity, the breaking should be done around the original hole.

The size of the broken material will vary with the strength and thickness of the base material and the amount of any reinforcement wire or rebar.

Harder material or more reinforcing wire or rebar will require taking smaller bites. To determine the most effective bite, start with 2 in. / 50 mm or smaller bites.

Bites can then be gradually increased until the broken piece becomes too large, requiring increased time to break off the piece.

Sticking of the tool bit occurs when too large a bite is being taken and the tool bit hammers into the material without the material fracturing. This causes the tool bit to become trapped in the surrounding material.

COLD WEATHER OPERATION

If the breaker is to be used during cold weather, preheat the hydraulic fluid at low engine speed. When using the normally recommended fluid, fluid temperature should be at or above 50 °F/10 °C (400 ssu/82 centistokes) before use.

Damage to the hydraulic system or breaker can result from use with fluid that is too viscous or thick.

TOOL PROTECTION & CARE

NOTICE

In addition to the Safety Precautions found in this manual, observe the following for equipment protection and care.

- Make sure all couplers are wiped clean before connection.
- The hydraulic circuit control valve must be in the “OFF” position when coupling or uncoupling hydraulic tools. Failure to do so may result in damage to the quick couplers and cause overheating of the hydraulic system.
- Always store the tool in a clean dry space, safe from damage or pilferage.
- Make sure the circuit PRESSURE hose (with male quick disconnect) is connected to the “IN” port. The circuit RETURN hose (with female quick disconnect) is connected to the opposite port. Do not reverse circuit flow. This can cause damage to internal seals.
- Always replace hoses, couplings and other parts with replacement parts recommended by Stanley Hydraulic Tools. Supply hoses must have a minimum working pressure rating of 2500 psi/172 bar.
- Do not exceed the rated flow and pressure. See Specifications in this manual for correct flow rate and pressure rating. Rapid failure of the internal seals may result.
- Always keep critical tool markings, such as warning stickers and tags legible.
- Do not force a small breaker to do the job of a large breaker.
- Keep tool bit sharp for maximum breaker performance. Make sure that tool bits are not chipped or rounded on the striking end.
- Never operate a breaker without a tool bit or without holding it against the work surface. This puts excessive strain on the breaker foot.
- Tool repair should be performed by experienced personnel only.
- Make certain that the recommended relief valves are installed in the pressure side of the system.
- Do not use the tool for applications for which it was not intended.

TROUBLESHOOTING

PROBLEM	CAUSE	REMEDY
Tool does not run.	Power unit not functioning.	Check power unit for power flow and pressure (7–9 gpm/26–34 lpm, 1500–2000 psi/105–140 bar or 5–6 gpm /18–22 lpm at 1500–2000 psi /105–140 bar.
	Couplers or hoses blocked.	Remove restriction.
	Pressure and return line hoses reversed at ports.	Be sure hoses are connected to their proper ports.
	Mechanical failure of piston or automatic valve.	Disassemble breaker and inspect for damaged parts.
Tool does not hit effectively.	Power unit not functioning.	Check power unit for power flow and pressure (7–9 gpm/26–34 lpm, 1500–2000 psi/105–140 bar or 5–6 gpm /18–22 lpm at 1500–2000 psi /105–140 bar.
	Couplers or hoses blocked.	Remove restriction.
	Low accumulator charge (pressure hose will pulse more than normal).	Recharge accumulator. Replace diaphragm if charge loss continues.
	Fluid too hot (above 140 °F/60 °C).	Provide cooler to maintain proper fluid temperature (130 °F/55 °C).
Tool operates slow.	Low gpm supply from power unit.	Check power unit for proper flow (7–9 gpm/26–34 lpm) or 5–6 gpm /18–22 lpm.
	High back-pressure.	Check hydraulic system for excessive back-pressure (over 200 psi/14 bar).
	Couplers or hoses blocked.	Remove restriction.
	Orifice plug blocked.	Remove restriction.
	Fluid too hot (above 140 °F/60 °C) or too cold (below 60 °F/16 °C).	Check power unit for proper fluid temperature. Bypass cooler to warm the fluid or provide cooler to maintain proper temperature.
	Relief valve set too low.	Adjust relief valve to 2100–2250 psi/145–155 bar.
Tool gets hot.	Hot fluid going through tool.	Check power unit. Be sure flow rate is not too high causing part of the fluid to go through the relief valve. Provide cooler to maintain proper fluid temperature (140 °F/60 °C max). Check the relief valve setting. Eliminate flow control devices.
Fluid leakage on tool bit.	Lower piston seal failure.	Replace seal.
Fluid leakage around trigger.	Valve spool seal failure.	Replace seals.

CHARGING THE ACCUMULATOR

ACCUMULATOR TESTING PROCEDURE

To check or charge the accumulator the following equipment is required.

- 31254 Charge Kit, which includes the following:
 - Accumulator Tester (Part Number 02835).
 - Charging Assembly (P/N 15304) (15304 includes a liquid filled gauge with snub valve, hose and fittings).
- NITROGEN bottle with an 800 psi/55 bar minimum charge.(Not included in 31254 kit)

CAUTION

This assembly contains nitrogen under pressure

1. Remove the plug from the handle or handle pivot.
2. Holding the chuck end of Accumulator Tester (P/N 02835) turn the gauge fully counterclockwise to ensure that the stem inside the chuck is completely retracted.
3. Thread the tester onto the accumulator charging valve. Do not advance the gauge-end into the chuck-end. Turn as a unit. Seat the chuck on the accumulator charging valve and hand tighten only.
4. Advance the valve stem of the tester by turning the gauge-end clockwise until a pressure is read on the gauge (charge pressure should be 500-700 psi/34-48 bar).
5. If pressure is OK unscrew the gauge-end from the chuck to retract the stem, then unscrew the entire tester assembly from the accumulator charging valve. If pressure is low, charge the accumulator as described in the following paragraph.
6. Install the plug.

ACCUMULATOR CHARGING

1. Perform steps 1 through 4 of the accumulator testing procedure above.
2. Connect the chuck of the charging assembly to the charging valve on the accumulator tester or, if preferred, remove the tester from the charging valve and connect the charging assembly chuck directly to the charging valve.
3. Adjust the snub valve to a charging pressure of 600 psi/42 bar. Note: While watching the pressure gauge, open snub valve slowly until it reaches the proper charge pressure (600-700 psi).

NOTE:

It may be necessary to set the gauge at 650-700 psi/45-48 bar to overcome any pressure drop through the charging system.

4. When the accumulator is fully charged close the snub valve on the charging assembly hose and remove the charging assembly chuck from the accumulator tester or tool charging valve.
5. If the accumulator tester has been used, be sure to turn the gauge-end fully counterclockwise before removing the tester from the charging valve of the tool. Install the valve cap.

UNDERWATER MODEL PREVENTATIVE MAINTENANCE

After each use, the movable portions of the tool that were exposed to water should be flushed with a water displacing oil such as WD40™. Remove any remaining water and debris as follows:

1. Turn the tool upside down (without the tool bit) and spray oil through the drive hex and side holes in the breaker foot assembly to displace any remaining water in the lower piston cavity.
2. Spray oil into the On/Off valve trigger slot area.
3. Dip or spray the entire tool.
4. Cycle the tool hydraulically several times before storing away.

CHARGING THE ACCUMULATOR

Charging the Accumulator (BR45 with Anti-Vibration Handles)

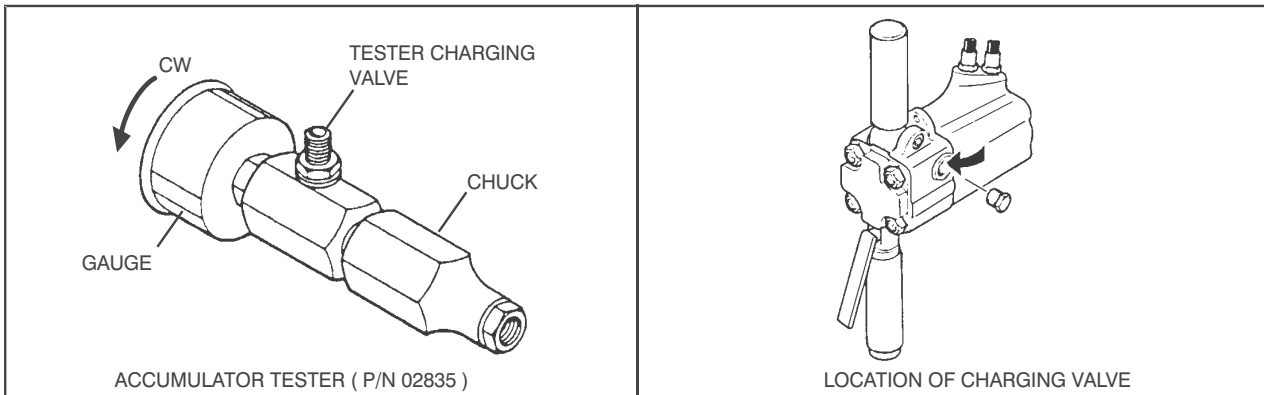
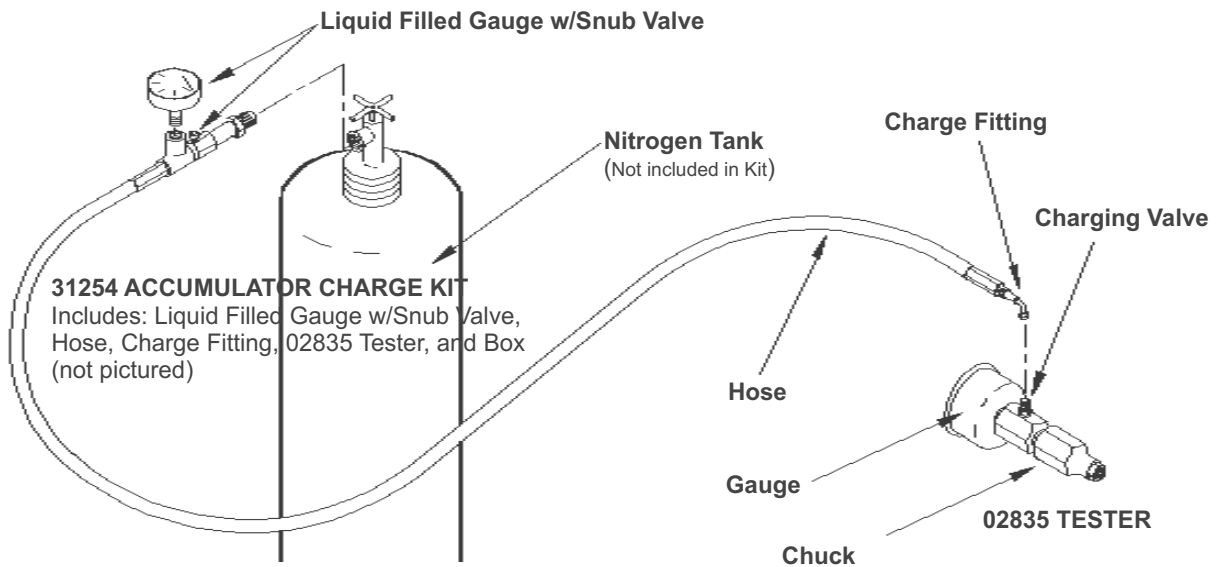

Figure 2



Charging the Accumulator (BR45 with T-Handles)

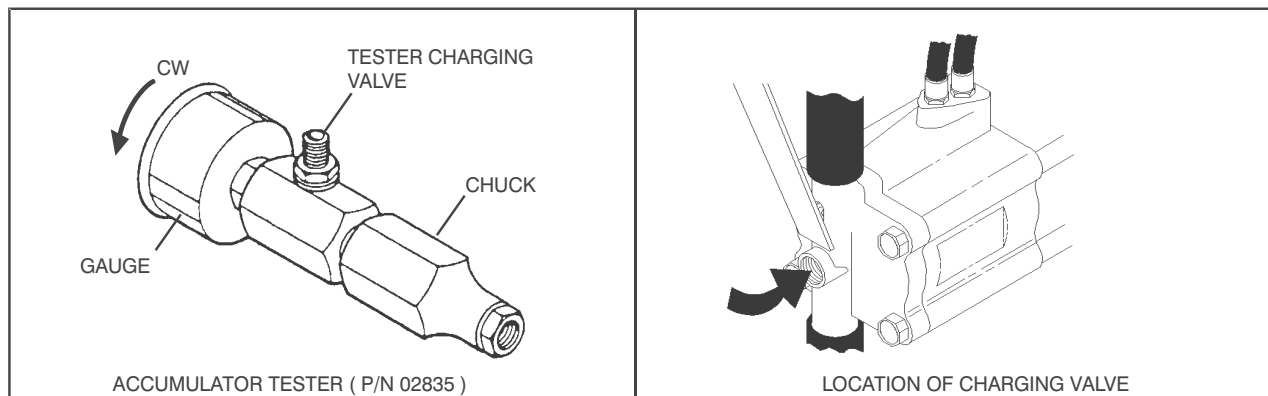

Figure 2. Charging the Accumulator

UNDERWATER TOOLS DEPTH GUIDELINE

UNDERWATER MODELS ONLY BR45350

⚠ CAUTION

DO NOT USE HYDRAULIC TOOLS THAT ARE NOT DESIGNATED AS AN “UNDERWATER” MODEL, OR THIS WILL RESULT IN DAMAGE TO THE TOOL.

For underwater hydraulic tools the applications are broken down into four quadrants depending on type of tool and method of operation.

The types of tools are percussive and rotational, each with different characteristics allowing for different depth operation. With percussive tools, the nitrogen accumulator PSI must counter the increase in ambient pressure found at lower depths. Since there is a maximum PSI for percussive tools they are limited to certain depths. Rotational tools do not have accumulators and thus capable of deeper depths.

The methods are broken into diver operated or remote operated vehicle (ROV). ROV's can reach lower depths and with an on-board hydraulic power source that is depth compensated, can operate hydraulic tools at depths of thousands of feet. ROV operation is still limited to the tool, for example a percussive tool has the same depth limitation whether ROV or diver operated.



Operation Overview

	Percussive	Rotational
Diver	Tools: Breakers, Hammer Drills and Chipping Hammers Max Depth: 500' - limitations due to accumulator PSI max (increase 40 PSI for every 100')	Tools: Grinders, Saws, Chain Saws Max Depth: 1000' - Reference hose sizing guide below
ROV	Tools: Breakers, Hammer Drills and Chipping Hammers Max Depth: 500' - limitations due to accumulator PSI max (increase 40 PSI for every 100')	Tools: Grinders, Saws, Chain Saws Max Depth: 1000' - Reference hose sizing guide below

Recommended Hose Diameters

Depth (ft)	8 GPM	12 GPM
100	5/8"	5/8"
300	3/4"	1"
600	1"	1"
1000	1"	1-1/4"



SPECIFICATIONS

Pressure Range.....	1500–2000 psi/105–140 bar
Flow Range	7–9 gpm / 26–34 lpm 4–6 gpm /15–22 lpm
Nominal Flow.....	8 gpm / 30 lpm or 5 gpm / 19 lpm
Maximum Back Pressure.....	250 Psi/17 bar
Couplers	HTMA Flush Face
Connect Size & Type	3/8 in. Male Pipe Hose Ends
Weight	T-Handle 51 lbs / 23 kg Anti-Vibration Handle 55 lbs / 25 kg
Overall Length	T-Handle 25.5 in. / 65 cm Anti-Vibration Handle 28.25 in. / 72 cm
Overall Width at Handles.....	T-Handle 14 in. / 35 cm Anti-Vibration Handle 17.5 in. / 44.5 cm
Max. Fluid Temperature.....	140 °F / 60 °C
System Type.....	Open or Closed Center
Port Size.....	SAE 8 O-ring
HTMA/EHTMA Category	Type 2
Nominal Pressure	1500 psi/103 bar
Max Pressure	2500 psi/138 bar
Max Relief Pressure	2150 psi/148 bar

BR45 ANTI-VIBE SOUND AND VIBRATION DECLARATION

Test conducted on BR4516801, operated at standard 8 gpm input

Measured A-weighted sound power level, Lwa (ref. 1pW) in decibels	105 dBA
Uncertainty, Kwa, in decibels.....	1.7 dBA
Guaranteed sound power level.....	107 dBA
Measured A-weighted sound pressure level, Lpa (ref. 20 µPa) at operator's position, in decibels	98 dBA
Uncertainty, Kpa, in decibels	3 dBA

Values determined according to noise test code given in ISO 15744, using the basic standard ISO3744

Test conducted by independent notified body to comply with 2000/14/EC:2005 requirements.

NOTE- The sum of a measured noise emission value and its associated uncertainty represents an upper boundary of the range of values which is likely to occur in measurements.

Declared vibration emission value in accordance with EN 12096	
Measured vibration emission value: 3-Axis	5.8 m/sec ²
Uncertainty: K.....	0.8 m/sec ²
Measured vibration emission value: 3-Axis with uncertainty	6.6 m/sec ²
Measured vibration emission value: Z-Axis	3.6 m/sec ²
Uncertainty: K.....	0.6 m/sec ²
Measured vibration emission value: Z-Axis with uncertainty	4.2 m/sec ²
Values determined according to ISO 28927-10:2011	

BR45 T-HANDLE VIBRATION DECLARATION

Declared vibration emission value in accordance with EN 12096	
Measured vibration emission value: 3-Axis	17.6 m/sec ²
Uncertainty: K.....	1.2 m/sec ²
Measured vibration emission value: 3-Axis with uncertainty	18.8 m/sec ²
Values determined according to ISO 28927-10:2011	

ACCESSORIES

7/8 IN. HEX × 3-1/4 IN. SHANK

Clay Spade 16 in./40.6 cm U/C 7/8" Hex.....	02328
3 in./76 mm Wide Chisel 14 in./35.6 cm U/C 7/8" Hex.....	02330
Asphalt Cutter 5 in./12.7 cm Wide Blade × 11 in./27.9 cm U/C 7/8" Hex.....	02341
Moil Point 18 in./45.7 cm U/C 7/8" Hex.....	04401
Moil Point 14 in./35.6 cm U/C 7/8" Hex Heavy Duty.....	04961
Rod Driver 3/4 in./19 mm Cup - 7/8" Hex.....	05255

1 IN. HEX × 4-1/4 IN. SHANK

Moil Point – 14 in. Long UC.....	07702
Narrow Chisel Point – 14 in. Long UC.....	07703
3-inch Chisel – 14 in. Long UC.....	07704
Clay Spade – 5-1/2 in. Blade.....	07705
Asphalt Wedge – 3 in. Wide.....	07706
Lagbolt Driver 1"x4-1/4" Shank 5" Clearance.....	208001
Lagbolt Driver 1"x4-1/4" Shank 9" Clearance.....	73355
Spike Driver Bit Assy.....	38709
Tie Tamper Steel 5".....	29431

1-1/8 IN. HEX × 6 IN. SHANK

Moil Point – 14 in. Long UC.....	02333
Chisel Point – 14 in. Long UC.....	03990
3-inch Chisel – 14 in. Long UC.....	02334
Clay Spade – 5-1/2 in. Blade.....	02331
Asphalt Wedge – 12 in.....	08106
Asphalt Cutter – 5 in. Wide.....	02332
Ground Rod Driver – 1 in. Rod.....	04176

1-1/4 IN. HEX × 6 IN. SHANK

Moil Point – 14 in. Long UC.....	02336
3-inch Chisel – 14 in. Long UC.....	02337
Clay Spade – 5-1/2 in. Blade.....	09262
Asphalt Cutter – 5 in. Wide.....	02335
Ground Rod Driver – 1 in. Rod.....	04367
Heavy Duty Chisel – 1 in.....	02338
Heavy Duty Moil Point – 18 in.....	04404
Clay Spade – 8 in.....	04405
Detachable Shank (Requires 17783).....	17782
Tamping Pad – 6 in. (Requires 17782).....	17783

UC Denotes the under collar dimension measured from bottom tip of tool to bottom surface of collar.

TEST EQUIPMENT

Accumulator Tester.....	02835
Flow and Pressure Tester.....	04182
Accumulator Charge Assembly (Includes Liquid Filled Gauge w/ Valve, Hose, & Charge Fitting).....	15304
Accumulator Charge Kit (Includes 02835 Tester, 15304 Charge Assy. and 372047 Charge Kit box).....	31254

SERVICE TOOLS

Flow Sleeve Removal Tube.....	04910
Seal Kit.....	04595
Split Ring (Auto Valve Removal).....	04908
Accumulator Cylinder Puller.....	05640
Accumulator Disassembly Tool.....	05508
Spacer (Flow Sleeve Installation).....	04909

PARTS ILLUSTRATION

BR45 T-HANDLE PARTS ILLUSTRATION

Pictured is a BR45120

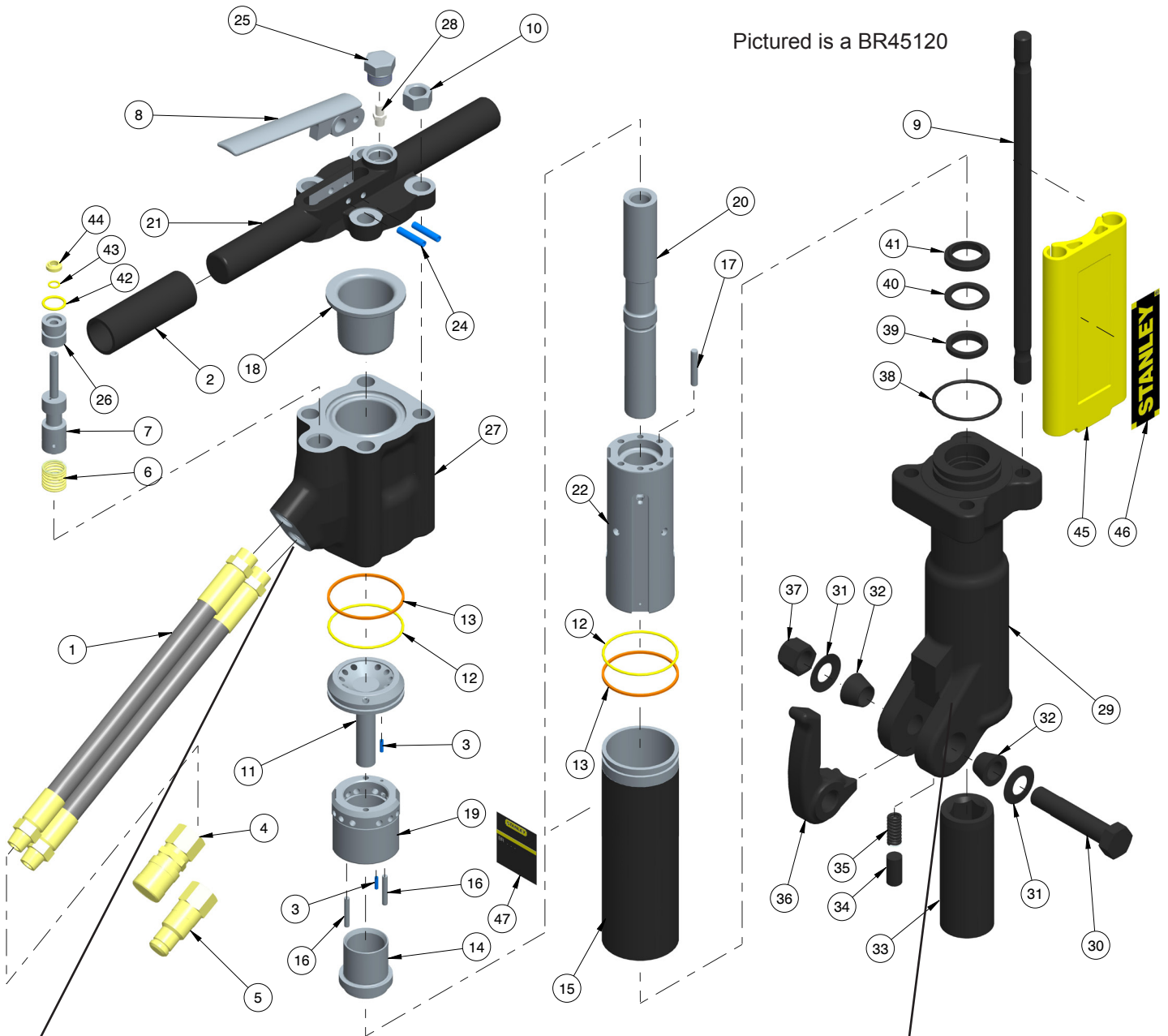

NOTE: 5-GPM Model (BR45550) has a Orifice Plug P/N-12832 Installed in the lower return port of item 27 Accumulator On-Off Valve Block (Orifice Plug not pictured).

See Pages 22 thru 24 for Breaker Foot Assemblies That Apply To Your Model.

PARTS LIST

BR45 T-HANDLE PARTS LIST

ITEM NO.	PART NO.	QTY	DESCRIPTION
1	01652	2	HOSE WHIP 12"
2	02494	2	HANDLE GRIP
3	02900	2	ROLL PIN 1/8 O.D. X .500 LG.
4	03972	1	COUPLER,3/8FEM.3/8NPT FL.FACE SET 03971
5	03973	1	COUPLER,3/8MALE 3/8NPT FL.FACE SET 03971
6	04058	1	COMPRESSION COIL SPRING
7	04077	1	VALVE SPOOL
8	04371	1	TRIGGER
9	04373	4	SIDE ROD
10	04374	4	HEX NUT
11	04378	1	PORTING BLOCK
12	04379	2	O-RING■
13	04381	2	BACK-UP RING■
14	04382	1	AUTOMATIC VALVE
15	04383	1	FLOW SLEEVE TUBE
16	04571	2	PUSH PIN
17	04605	4	PUSH PIN
18	07479	1	ACCUMULATOR DIAPHRAGM
19	07480	1	AUTOMATIC VALVE BODY
20	07481	1	PISTON
	12833	1	PISTON (BR45550) (5-GPM MODEL ONLY)
21	07483	1	HANDLE
22	07485	1	FLOW SLEEVE
23	----	--	NO ITEM
24	07492	2	ROLL PIN
25	07493	1	O-RING PLUG MALE
26	04057	1	BUSHING
27	11588	1	ACCUMULATOR ON-OFF VALVE BLOCK
28	20499	1	CHARGE VALVE
29	62334	1	BREAKER FOOT ASSY (INCLUDES ITEMS 29 thru 41) ALSO SEE BREAKER FOOT ASSY'S STARTING AT PAGE 22
30	04983	1	FOOT LATCH BOLT*
31	04985	2	SPRING WASHER*

ITEM NO.	PART NO.	QTY	DESCRIPTION
32	01269	2	RUBBER SLEEVE*
33	04081	1	HEX BUSHING 1-1/8"*
34	08411	1	DETENT*
35	01744	1	SPRING*
36	01837	1	LATCH*
37	04984	1	NYLOCK NUT*
38	02022	1	O-RING*■
39	04387	1	ROD WIPER*■
40	04780	1	BACK UP WASHER*
41	04386	1	CUP SEAL*■
42	00293	1	O-RING■
43	01362	1	O-RING■
44	04056	1	ROD WIPER■
45	72919	2	FILLER (SNAP ON)
46	14090	2	STANLEY LOGO STICKER
47	72928	1	NAME TAG BR45 (8-GPM)
	72921	1	NAME TAG BR45 (5-GPM)

SEAL KIT PART NUMBER 04595

■ DENOTES PART IN SEAL KIT

* DENOTES PART OF BREAKER FOOT ASSEMBLY

BUSHING ASSY 07699 (INCLUDES ITEMS 26, 42, 43, and 44)

PARTS ILLUSTRATION

BR45 ANTI-VIBRATION HANDLE PARTS ILLUSTRATION

Pictured is a BR4516801

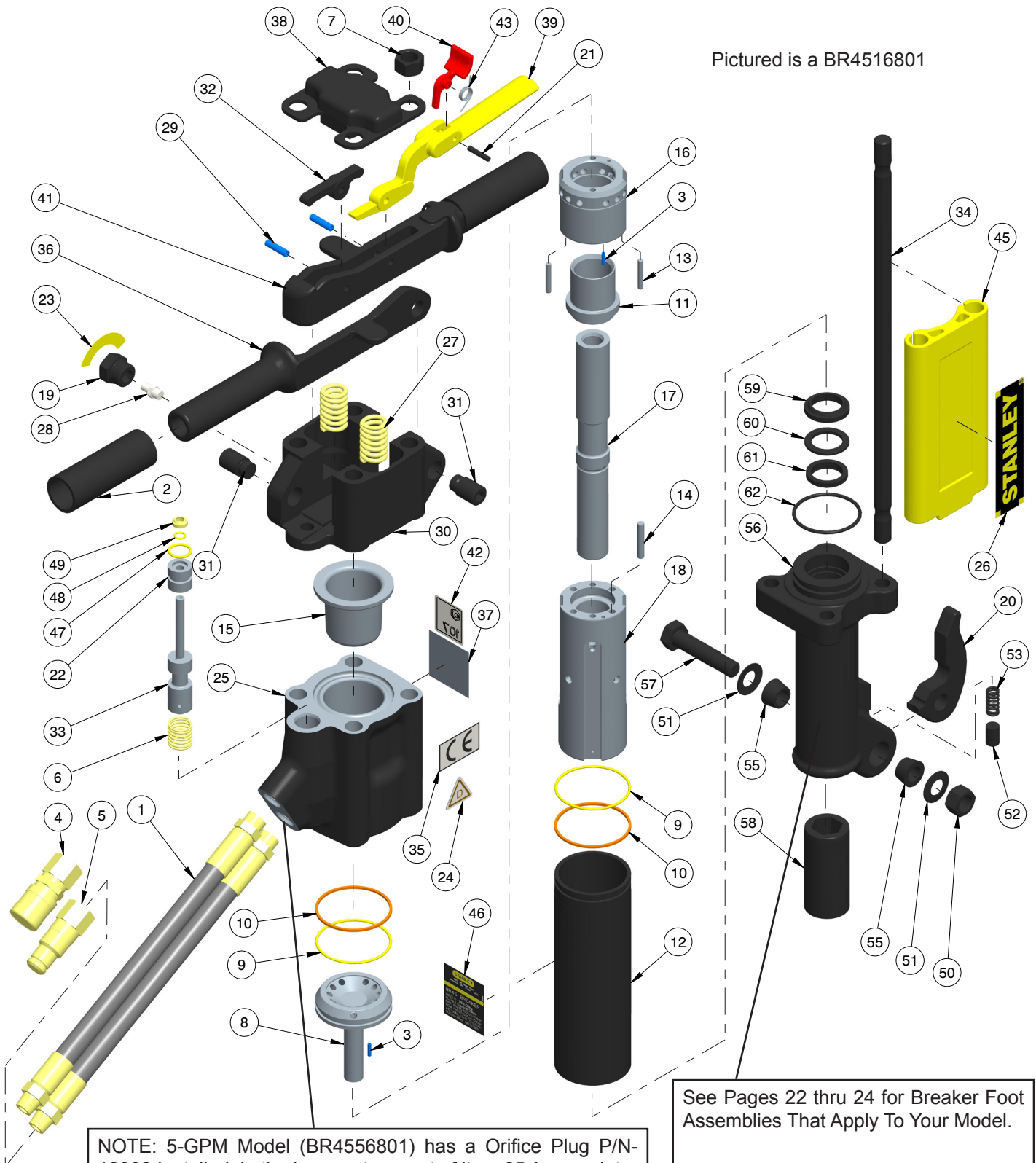

NOTE: 5-GPM Model (BR4556801) has a Orifice Plug P/N-12832 Installed in the lower return port of item 25 Accumulator On-Off Valve Block (Orifice Plug not pictured).

See Pages 22 thru 24 for Breaker Foot Assemblies That Apply To Your Model.

PARTS LIST

BR45 ANTI-VIBRATION HANDLE PARTS LIST

ITEM NO.	PART NO.	QTY	DESCRIPTION
1	01652	2	HOSE WHIP 12"
	56725	2	HOSE ASSY 18" BR45158
	66727	2	HOSE ASSY BR45158BN
2	02494	2	HANDLE GRIP
3	02900	2	ROLL PIN
4	03972	1	COUPLER,3/8FEM. 3/8NPT FL.FACE SET 03971
5	03973	1	COUPLER,3/8MALE 3/8NPT FL.FACE SET 03971
6	04058	1	COMPRESSION COIL SPRING
7	04374	4	HEX NUT
8	04378	1	PORTING BLOCK
9	04379	2	O-RING*
10	04381	2	BACK-UP RING*
11	04382	1	AUTOMATIC VALVE
12	04383	1	FLOW SLEEVE TUBE
13	04571	2	PUSH PIN
14	04605	4	PUSH PIN
15	07479	1	ACCUMULATOR DIAPHRAGM
16	07480	1	AUTOMATIC VALVE BODY
17	07481	1	PISTON
	12833	1	PISTON (BR4556801) (5-GPM MODEL ONLY)
18	07485	1	FLOW SLEEVE
19	07493	1	PLUG - BR4514801, BR4516801, BR4516807
	20510	1	PLUG - BR45125S, BR45135S, BR4513516
20	04394	1	LATCH
21	07624	1	ROLL PIN
22	07699	1	■ BUSHING ASSY.
23	10180	1	CAUTION N2 GAS STICKER
24	11207	1	CIRCUIT TYPE "D" STICKER
25	11588	1	ACCUMULATOR ON-OFF VALVE BLOCK
26	14090	2	STANLEY LOGO
27	20498	2	SPRING
	20540	2	SPRING BR45158/BR45158BN
	20541	2	SPRING BR45158/BR45158BN
28	20499	1	CHARGE VALVE
29	20500	2	ROLL PIN
30	20505	1	HANDLE PIVOT BLOCK
31	20508	2	PIVOT SCREW
32	20511	1	LEVER
33	20515	1	VALVE SPOOL
34	20517	4	SIDE ROD
35	28322	1	STICKER "CE"
36	28369	1	HANDLE (GUARDED)
37	28409	1	COMPOSITE STICKER
38	28494	1	TOP PLATE
39	58526	1	CAST TRIGGER
40	58527	1	TRIGGER LOCK
41	58529	1	TRIGGER HANDLE (WITH TRIGGER LOCK)
	29045	1	TRIGGER HANDLE (NON-TRIGGER LOCK)
42	58601	1	GUARANTEED SOUND POWER LEVEL - 107dB
43	66828	1	TORSION SPRING
45	72919	2	FILLER (SNAP-ON)
46	72927	1	NAME TAG-BR45 8-GPM
	72920	1	NAME TAG-BR45 5-GPM
47	00293	1	O-RING*
48	01362	1	O-RING*
49	04056	1	ROD WIPER*
50	04374	1	LOCK NUT
51	04716	2	SPRING WASHER
52	04393	1	DETENT
53	04392	1	SPRING
54	-----	--	NO ITEM
55	04715	2	RUBBER CONE WASHER
56	07510	1	BREAKER FOOT ASSY (INCLUDES ITEMS 50 THRU 62 & 20) (SEE BREAKER FOOT ASSY'S ON PAGES 22-26)
57	04717	1	LATCH BOLT
58	07477	1	HEX BUSHING
59	04386	1	CUP SEAL*
60	04780	1	BACK UP WASHER
61	04387	1	ROD WIPER*
62	02022	1	O-RING*

SEAL KIT PART NUMBER 04595

■ DENOTES PART IN SEAL KIT

* DENOTES PART OF BREAKER FOOT ASSEMBLY

■ BUSHING ASSY 07699 (INCLUDES ITEMS 22, 47, 48, and 49)

BREAKER FOOT ASSY'S

BREAKER FOOT ASSEMBLY (STANDARD) P/N-07694 (MODEL BR4514801)

07694 Assembly Includes Items 1 thru 13 Below.

ITEM	PART #	QTY	DESCRIPTION
1	01742	1	HEX BUSHING 7/8"
2	02022	1	O-RING
3	04374	1	HEX NUT
4	04386	1	CUP SEAL
5	04387	1	ROD WIPER
6	04392	1	SPRING

ITEM	PART #	QTY	DESCRIPTION
7	04393	1	DETENT
8	04394	1	LATCH
9	04715	2	TAPER SLEEVE
10	04716	2	SPRING WASHER
11	04717	1	LATCH BOLT
12	04780	1	BACK UP WASHER
13	07695	1	BREAKER FOOT

NOTE: IF YOU ARE REPLACING THE HEX BUSHING YOU MUST PURCHASE A COMPLETE BREAKER ASSEMBLY.

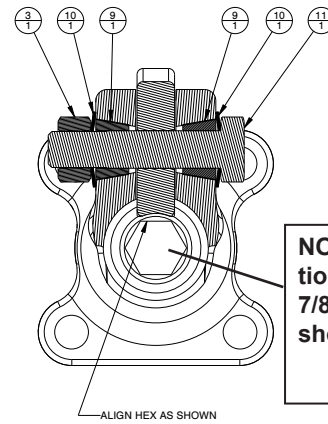
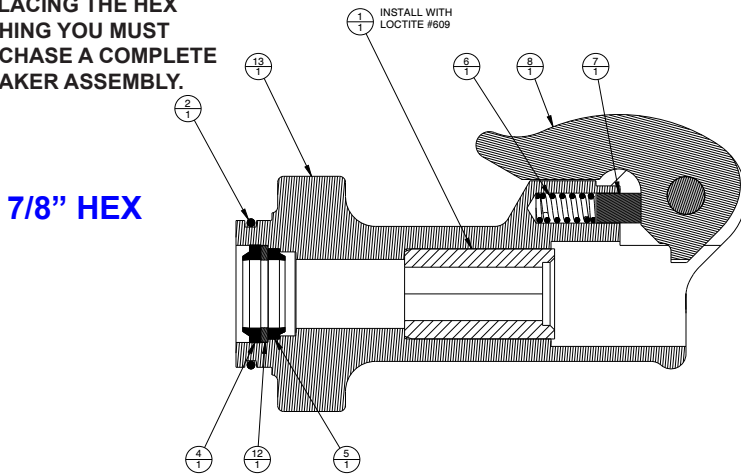

NOTE: Hex orientation is different than 7/8" breaker foot assy shown below.

BREAKER FOOT ASSEMBLY (STANDARD) P/N-07899 (MODEL BR45110)

07899 Assembly Includes Items 1 thru 13 Below.

ITEM	PART #	QTY	DESCRIPTION
1	01742	1	HEX BUSHING
2	02022	1	O-RING
3	04374	1	HEX NUT
4	04386	1	CUP SEAL
5	04387	1	ROD WIPER
6	04392	1	SPRING

ITEM	PART #	QTY	DESCRIPTION
7	04393	1	DETENT
8	04394	1	LATCH
9	04715	2	TAPER SLEEVE
10	04716	2	SPRING WASHER
11	04717	1	LATCH BOLT
12	04780	1	BACK UP WASHER
13	07695	1	BREAKER FOOT

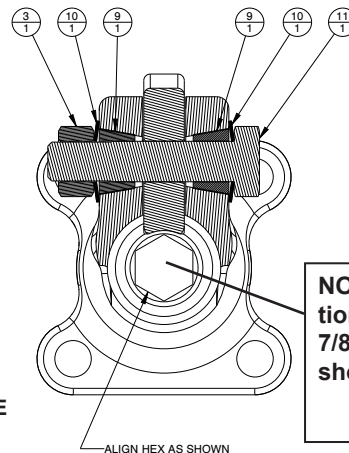
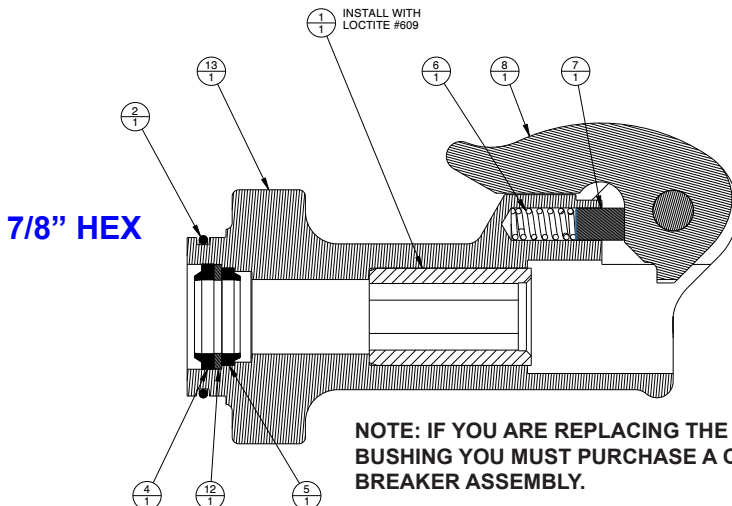

NOTE: Hex orientation is different than 7/8" breaker foot assy shown above.

BREAKER FOOT ASSY'S

BREAKER FOOT ASSEMBLY (STANDARD) P/N-07510 (MODELS BR4516801, BR4516807, BR4516807A and BR4556801). 07510 Assembly Includes Items 1 thru 13 Below.

ITEM	PART #	QTY	DESCRIPTION
1	02022	1	O-RING
2	04374	1	HEX NUT
3	04386	1	CUP SEAL
4	04387	1	ROD WIPER
5	04392	1	SPRING
6	04393	1	DETENT

ITEM	PART #	QTY	DESCRIPTION
7	04394	1	LATCH
8	04715	2	TAPER SLEEVE
9	04716	2	SPRING WASHER
10	04717	1	LATCH BOLT
11	04780	1	BACK UP WASHER
12	07445	1	BREAKER FOOT
13	07477	1	HEX BUSHING 1"

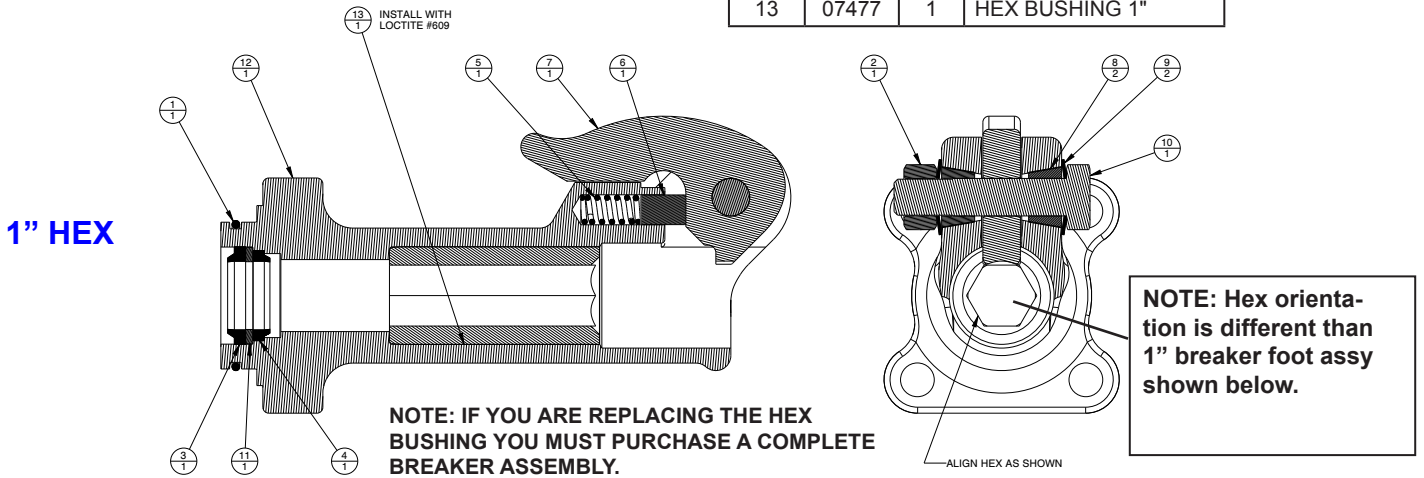

BREAKER FOOT ASSEMBLY (STANDARD) P/N-07489 (MODELS BR45150, BR45550, BR45158, BR45158BN) 07489 Assembly Includes Items 1 thru 13 Below.

ITEM	PART #	QTY	DESCRIPTION
1	02022	1	O-RING
2	04374	1	HEX NUT
3	04386	1	CUP SEAL
4	04387	1	ROD WIPER
5	04392	1	SPRING
6	04393	1	DETENT

ITEM	PART #	QTY	DESCRIPTION
7	04394	1	LATCH
8	04715	2	TAPER SLEEVE
9	04716	2	SPRING WASHER
10	04717	1	LATCH BOLT
11	04780	1	BACK UP WASHER
12	07445	1	BREAKER FOOT
13	07477	1	HEX BUSHING 1"

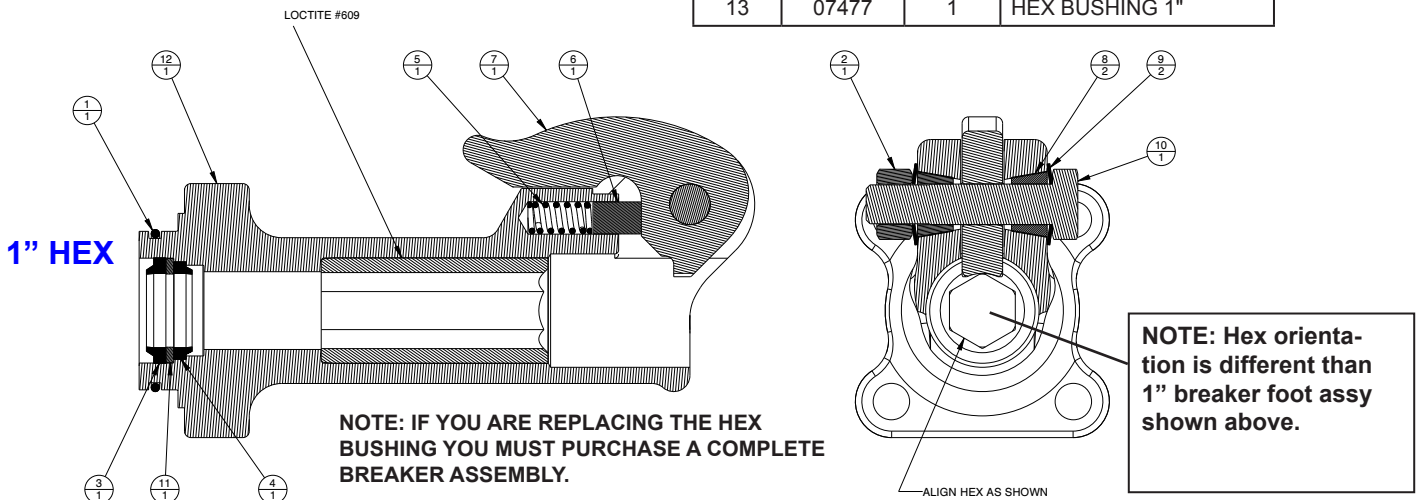

BREAKER FOOT ASSY'S

BREAKER FOOT ASSEMBLY (UNDERWATER) P/N-08856 (MODELS BR45350)
08856 Assembly Includes Items 1 thru 13 Below.

ITEM	PART #	QTY	DESCRIPTION
1	02022	1	O-RING
2	04374	1	HEX NUT
3	04386	1	CUP SEAL
4	04387	1	ROD WIPER
5	04392	1	SPRING
6	04393	1	DETENT

ITEM	PART #	QTY	DESCRIPTION
7	04394	1	LATCH
8	04715	2	TAPER SLEEVE
9	04716	2	SPRING WASHER
10	04717	1	LATCH BOLT
11	04780	1	BACK UP WASHER
12	07477	1	HEX BUSHING 1"
13	08857	1	BREAKER FOOT U/W

NOTE: IF YOU ARE REPLACING THE HEX BUSHING YOU MUST PURCHASE A COMPLETE BREAKER ASSEMBLY.

1" HEX

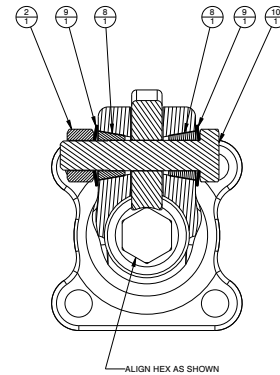
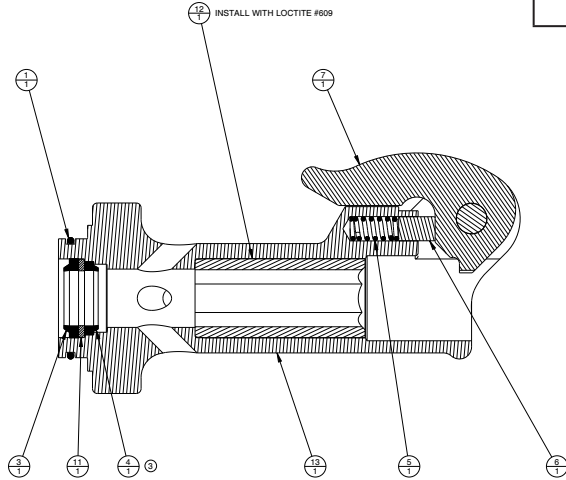

BREAKER FOOT ASSEMBLY (STANDARD) P/N-62334 (MODELS BR45120 and BR45120D)
62334 Assembly Includes Items 1 thru 14 Below.

ITEM	PART #	QTY	DESCRIPTION
1	01269	2	TAPER SLEEVE
2	01744	1	SPRING
3	01837	1	LATCH
4	02022	1	O-RING
5	04081	1	HEX BUSHING 1-1/8"
6	04386	1	CUP SEAL

ITEM	PART #	QTY	DESCRIPTION
7	04387	1	ROD WIPER
8	04780	1	BACK UP WASHER
9	04983	1	FOOT LATCH BOLT
10	04984	1	NYLOCK NUT
11	04985	2	SPRING WASHER
12	08159	1	INSERT
13	08411	1	DETENT
14	32275	1	BREAKER FOOT

1-1/8" HEX

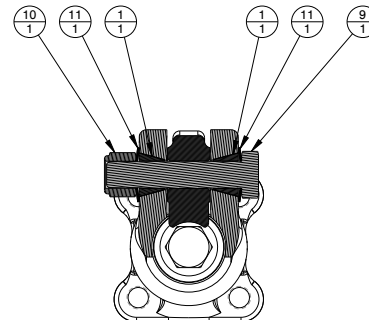
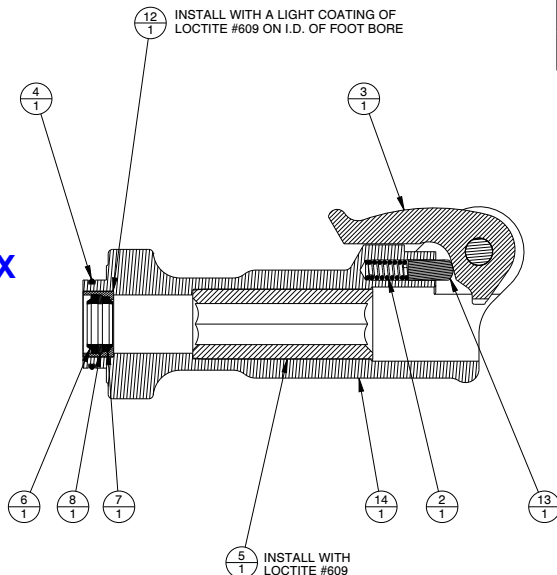

NOTE: IF YOU ARE REPLACING THE INSERT OR HEX BUSHING YOU MUST PURCHASE A COMPLETE BREAKER ASSEMBLY.

BREAKER FOOT ASSY'S

BREAKER FOOT ASSEMBLY (EASY-RIDE) P/N-08154 (MODELS BR45120E and BR45125S)
 08154 Assembly Includes Items 1 thru 17 Below.

ITEM	PART #	QTY	DESCRIPTION
1	01269	2	TAPER SLEEVE
2	01744	1	SPRING
3	01837	1	LATCH
4	02022	1	O-RING
5	04386	1	CUP SEAL
6	04387	1	ROD WIPER
7	04780	1	BACK UP WASHER
8	04983	1	FOOT LATCH BOLT

ITEM	PART #	QTY	DESCRIPTION
9	04984	1	NYLOCK NUT
10	04985	2	SPRING WASHER
11	07517	1	HEX BUSHING 1-1/8"
12	07522	1	RETAINING RING
13	08115	1	COLLAR SUPPORT ASSY.
14	08157	1	BREAKER FOOT
15	08158	1	SPRING
16	08159	1	INSERT
17	08411	1	DETENT

1-1/8" HEX

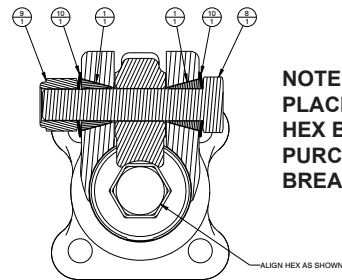
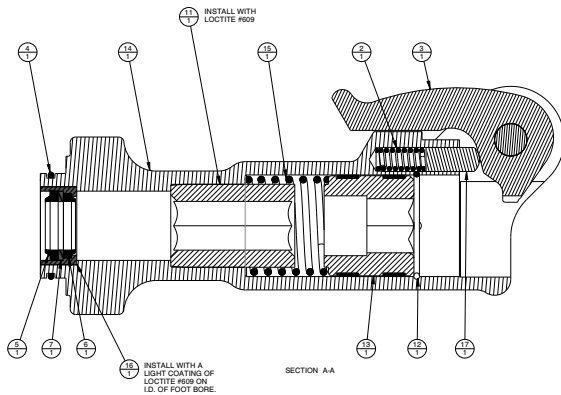

NOTE: IF YOU ARE REPLACING THE INSERT OR HEX BUSHING YOU MUST PURCHASE A COMPLETE BREAKER ASSEMBLY.

BREAKER FOOT ASSEMBLY (STANDARD) P/N-72931 (MODEL BR45130)
 72931 Assembly Includes Items 1 thru 14 Below.

ITEM	PART #	QTY	DESCRIPTION
1	01269	2	TAPER SLEEVE
2	01744	1	SPRING
3	01837	1	LATCH
4	02022	1	O-RING
5	04386	1	CUP SEAL
6	04387	1	ROD WIPER

ITEM	PART #	QTY	DESCRIPTION
7	04597	1	HEX BUSHING 1-1/4"
8	04780	1	BACK UP WASHER
9	04983	1	FOOT LATCH BOLT
10	04984	1	NYLOCK NUT
11	04985	2	SPRING WASHER
12	08159	1	INSERT
13	08411	1	DETENT
14	32275	1	BREAKER FOOT

1-1/4" HEX

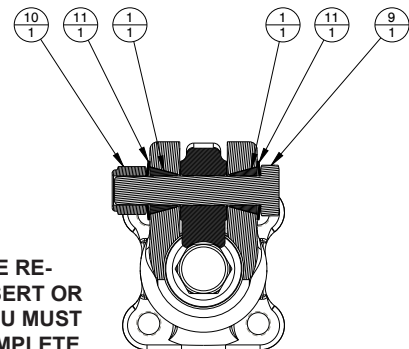
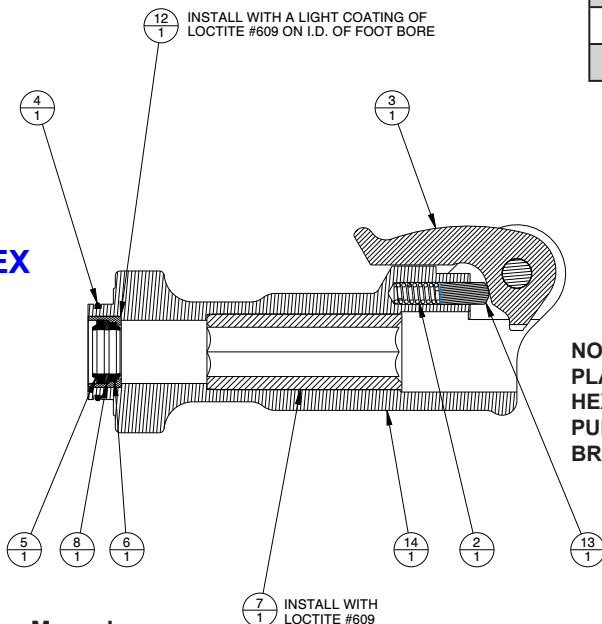

NOTE: IF YOU ARE REPLACING THE INSERT OR HEX BUSHING YOU MUST PURCHASE A COMPLETE BREAKER ASSEMBLY.

BREAKER FOOT ASSY'S

BREAKER FOOT ASSEMBLY (EASY-RIDE) P/N-08081 (MODELS BR45130E, BR45130EL, BR45135S and BR4513516). 08081 Assembly Includes Items 1 thru 17 Below.

ITEM	PART #	QTY	DESCRIPTION
1	01269	2	TAPER SLEEVE
2	01744	1	SPRING
3	01837	1	LATCH
4	02022	1	O-RING
5	04386	1	CUP SEAL
6	04387	1	ROD WIPER
7	04780	1	BACK UP WASHER
8	04983	1	FOOT LATCH BOLT

ITEM	PART #	QTY	DESCRIPTION
9	04984	1	NYLOCK NUT
10	04985	2	SPRING WASHER
11	07518	1	HEX BUSHING 1-1/4"
12	07522	1	RETAINING RING
13	08116	1	COLLAR SUPPORT ASSY.
14	08157	1	BREAKER FOOT
15	08158	1	SPRING
16	08159	1	INSERT
17	08411	1	DETENT

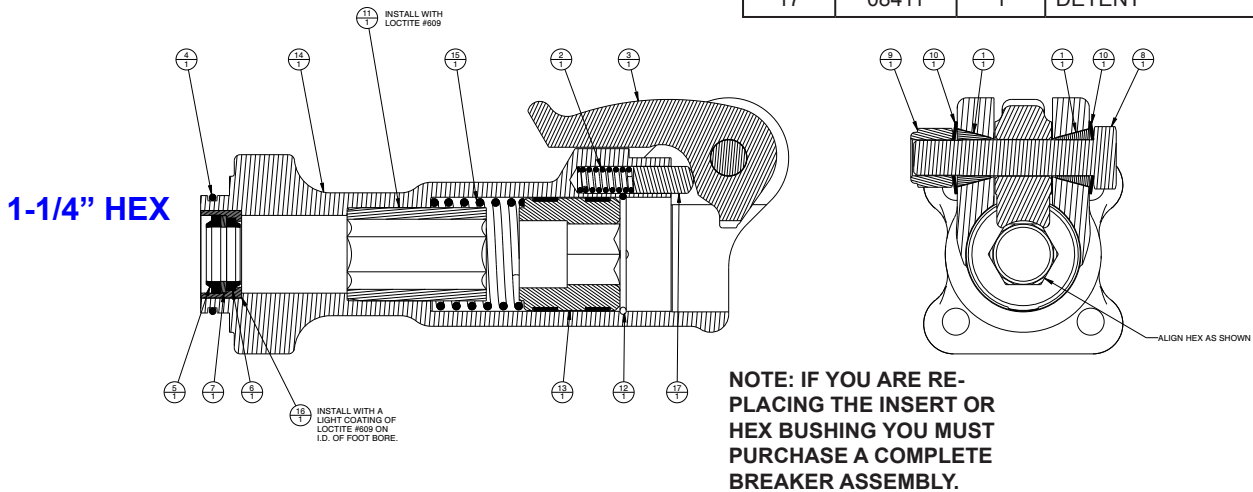

STANLEY®

Stanley Hydraulic Tools
3810 SE Naef Road
Milwaukie, Oregon 97267-5698 USA
(503) 659-5660 / Fax (503) 652-1780
www.stanleyhydraulics.com