

# STANLEY®

## CO25 HYDRAULIC CUT-OFF SAW

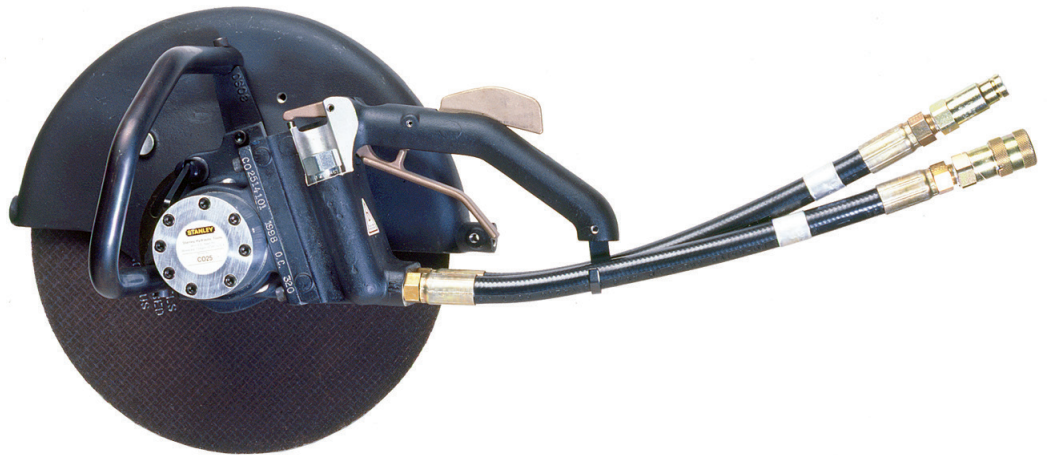

### USER MANUAL Safety, Operation and Maintenance



© 2014 Stanley Black & Decker, Inc.  
New Britain, CT 06053  
U.S.A.  
34962 2-2015 Ver-14

# DECLARATION OF CONFORMITY

DECLARATION OF CONFORMITY  
ÜBEREINSTIMMUNGS-ERKLÄRUNG  
DECLARATION DE CONFORMITE CEE  
DECLARACION DE CONFORMIDAD  
DICHIARAZIONE DI CONFORMITA



I, the undersigned:  
Ich, der Unterzeichnende:  
Je soussigné:  
El abajo firmante:  
Io sottoscritto:

**Weisbeck, Andy**

Surname and First names/Familiennname und Vornamen/Nom et prénom/Nombre y apellido/Cognome e nome

hereby declare that the equipment specified hereunder:  
bestätige hiermit, daß erklaren Produkt genannten Werk oder Gerät:  
déclare que l'équipement visé ci-dessous:  
Por la presente declaro que el equipo se especifica a continuación:  
Dichiaro che le apparecchiature specificate di seguito:

- Category: **Cut-Off-Saw, Hydraulic**  
Kategorie:  
Catégorie:  
Categoria:  
Categoria:
- Make/Marke/Marque/Marca/Marca **Stanley**
- Type/Typ/Type/Tipo/Tipo: **CO2554101, CO2514101**
- Serial number of equipment:  
Seriennummer des Geräts:  
Numéro de série de l'équipement:  
Numero de serie del equipo:  
Matricola dell'attrezzatura: **All**

Has been manufactured in conformity with  
Wurde hergestellt in Übereinstimmung mit  
Est fabriqué conformément  
Ha sido fabricado de acuerdo con  
E' stata costruita in conformità con

Directive/Standards Richtlinie/Standards Directives/Normes Directriz/Los Normas Direttiva/Norme	No. Nr Numéro No n.	Approved body Prüfung durch Organisme agréé Aprobado Collaudato
ISO	3744:2010	Self
ISO	20643-A1:2012	Self
Machinery Directive	2006/42/EC:2006	Self
ISO	19432:2012	Self
ISO	11148-7:2012	Self

- Special Provisions: **None**  
Spezielle Bestimmungen:  
Dispositions particulières:  
Provisiones especiales:  
Disposizioni speciali:
- Representative in the Union: **Patrick Vervier, Stanley Dubuis 17-19, rue Jules Berthonneau-BP 3406 41034 Blois Cedex, France.**  
Vertreter in der Union/Représentant dans l'union/Representante en la Union/Rappresentante presso l'Unione

Done at/Ort/Fait à/Dado en/Fatto a Stanley Hydraulic Tools, Milwaukie, Oregon USA Date/Datum/le/Fecha/Data 8-10-2013

Signature/Unterschrift/Signature/Firma/Firma

Position/Position/Fonction/Cargo/Posizione Director of Product Development

# TABLE OF CONTENTS

CERTIFICATE OF CONFORMITY.....	2
SAFETY SYMBOLS.....	4
SAFETY PRECAUTIONS.....	5
TOOL STICKERS & TAGS.....	7
HYDRAULIC HOSE TYPES.....	8
HOSE RECOMMENDATIONS.....	9
HTMA / EHTMA REQUIREMENTS.....	10
OPERATION.....	11
PREOPERATION PROCEDURES.....	11
CONNECT HOSES.....	11
TOOL OPERATION.....	11
STARTUP.....	11
GENERAL OPERATION.....	12
WET CUTTING.....	12
BROKEN CUT-OFF WHEELS.....	12
SHUTDOWN.....	12
PERIODIC MAINTENANCE.....	13
THRUST COLLAR AND INSIDE/OUTSIDE COLLAR INSPECTION.....	13
DRIVE-SHAFT SPEED CHECK.....	13
BEARING CHECK.....	13
CARE AND STORAGE.....	13
CUTOFF WHEELS.....	13
TOOL.....	13
CUTOFF WHEEL REPLACEMENT.....	14
COLD WEATHER OPERATION.....	14
EQUIPMENT PROTECTION & CARE.....	15
TROUBLESHOOTING.....	16
SPECIFICATIONS.....	17
ACCESSORIES.....	17
CO25 PARTS ILLUSTRATION.....	18
CO25 PARTS LIST.....	19

## IMPORTANT

To fill out a Product Warranty Validation form, and for information on your warranty, visit [Stanleyhydraulics.com](http://Stanleyhydraulics.com) and select the Company tab, Warranty.  
(NOTE: The warranty Validation record must be submitted to validate the warranty).

**SERVICING:** This manual contains safety, operation, and routine maintenance instructions. Stanley Hydraulic Tools recommends that servicing of hydraulic tools, other than routine maintenance, must be performed by an authorized and certified dealer. Please read the following warning.

## ⚠ WARNING

**SERIOUS INJURY OR DEATH COULD RESULT FROM THE IMPROPER REPAIR OR SERVICE OF THIS TOOL.**

**REPAIRS AND / OR SERVICE TO THIS TOOL MUST ONLY BE DONE BY AN AUTHORIZED AND CERTIFIED DEALER.**

For the nearest authorized and certified dealer, call Stanley Hydraulic Tools at the number listed on the back of this manual and ask for a Customer Service Representative.



# SAFETY PRECAUTIONS

Tool operators and maintenance personnel must always comply with the safety precautions given in this manual and on the stickers and tags attached to the tool and hose.

These safety precautions are given for your safety. Review them carefully before operating the tool and before performing general maintenance or repairs.

Supervising personnel should develop additional precautions relating to the specific work area and local safety regulations. If so, place the added precautions in the space provided on the previous page.

The CO25 Hydraulic Cut-Off Saw will provide safe and dependable service if operated in accordance with the instructions given in this manual. Read and understand this manual and any stickers and tags attached to the tool and hose before operation. Failure to do so could result in personal injury or equipment damage.



- The operator must start in a work area without bystanders. Flying debris can cause serious injury.
- Do not operate the tool unless thoroughly trained or under the supervision of an instructor. Establish a training program for all operators to ensure safe operation.
- Always wear safety equipment such as goggles, ear, breathing and head protection, and safety shoes at all times when operating the tool. Use gloves and aprons when necessary.
- The operator must be familiar with all prohibited work areas such as excessive slopes and dangerous terrain conditions.
- Maintain proper footing and balance at all times. Always hold the tool with both hands when the unit is running. Use a firm grip.
- Do not inspect or clean the tool while the hydraulic power source is connected. Accidental engagement of the tool can cause serious injury.
- Always connect hoses to the tool hose couplers before energizing the hydraulic power source. Be sure all hose connections are tight and are in good condition.
- Do not operate the tool at oil temperatures above 140°F/60°C. Operation at higher temperatures can cause higher than normal temperatures at the tool which can result in operator discomfort.

- Do not operate a damaged, improperly adjusted, or incompletely assembled tools.
- Never wear loose clothing that can get entangled in the working parts of the tool.
- Keep all parts of your body away from the rotating parts. Long hair or loose clothing can become drawn into rotating components.
- Always use accessories that conform to the specifications given in this manual.
- Release the trigger if the power supply has been interrupted.
- When working near electrical conductors, always assume that all conductors are energized and that insulation, clothing and hoses can conduct electricity. Use hose labeled and certified as non-conductive.
- To avoid personal injury or equipment damage, all tool repair, maintenance and service must only be performed by authorized and properly trained personnel.

**Warning:** Use of this tool on certain materials during demolition could generate dust potentially containing a variety of hazardous substances such as asbestos, silica or lead. Inhalation of dust containing these or other hazardous substances could result in serious injury, cancer or death. Protect yourself and those around you. Research and understand the materials you are cutting. Follow correct safety procedures and comply with all applicable national, state or provisional health and safety regulations relating to them, including, if appropriate arranging for the safe disposal of the materials by a qualified person.

# SAFETY PRECAUTIONS

- Never carry the tool or put it down while the wheel is rotating. Make sure it is completely stopped before moving your position or set the tool down.
- Do not operate the tool with the wheel guard removed.
- Keep the handles dry, clean and free of oil at all times.
- Operate the tool in well ventilated areas only.
- Do not operate the tool if the wheel does not stop when the trigger is released.
- Inspect the wheel guard and collars for damage after any wheel breakage on the tool.
- Always use full throttle when cutting.
- Never cock, jam or wedge the wheel during the cut. Do not use the side of the wheel as a cutting surface and be aware of kick-back from the saw.
- Make sure the tool is designed for the wheel direction suitable for the job. Do not reverse the direction of the wheel rotation by changing the direction of the oil flow.
- Always operate the tool within its rated capacity. Never exceed the maximum operating speed marked on the wheel.
- Do not operate the tool near flammable materials, sparks can ignite flammable or combustible materials.
- Do not over-reach.
- Do not use the tool for applications for which it was not designed.
- Keep the wheel off all surfaces when starting the saw.
- Do not attempt to adjust the flow control on the valve handle.
- Know the location of buried or covered services before starting work.
- Adjust the wheel guard so it is between you and the cutting wheel.
- Never operate the tool when you are tired.

## CUT-OFF WHEEL SAFETY

- Always inspect the cut-off wheels for possible damage before operating the tool. Do not use a wheel that is cracked or otherwise damaged.
- Never transport or store the tool with the cut-off wheel

mounted on the saw.

- If the cut-off saw is dropped with a cutting wheel installed, thoroughly examine the cutting wheel before use.
- Make sure the cutting wheel is correctly mounted and tightened before use.
- Operate the cut-off saw at no load for 30 seconds in a safe position. If considerable vibration or other defects are detected, stop operation of the tool immediately and determine the cause. Do not use the tool until the defect is corrected.
- Only use cutting wheels that comply with ANSI B7.5/ ISO 525, 603.
- Check that the maximum operating speed of the cutting wheel is equal to or greater than the rated shaft speed of the cut-off saw. Wheels must be rated at 4700 rpm minimum.
- Warning: Hydraulic fluid under pressure could cause skin injection injury. If you are injured by hydraulic fluid, get medical attention immediately
- Always support and secure items being worked on.
- Caution when handling the work piece after cutting, object can be hot and have sharp edges, use your personal protection equipment.
- Keep your work area clean and clear of tripping hazards, oily surfaces and hoses laying about can be hazardous.
- Make sure adequate lighting is always available.
- Never operate the tool if you cannot be sure that underground utilities are not present. Underground electrical utilities present an electrocution hazard. Underground gas utilities present an explosion hazard. Other underground utilities may present other hazards.
- Do not operate this tool in a potentially explosive environment. Do not grind on vessels containing combustible substances.
- Any use of this tool outside those stated in this manual are forbidden.

# TOOL STICKERS & TAGS

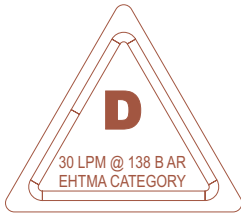

11207  
CIRCUIT TYPE D DECAL  
(CE MODELS ONLY)



05152  
ADDRESS DECAL

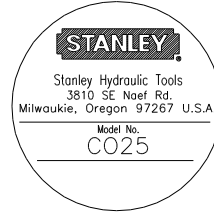

33206  
CO25 NAME TAG



28322  
CE DECAL  
(CE MODELS ONLY)



03786  
GPM DECAL

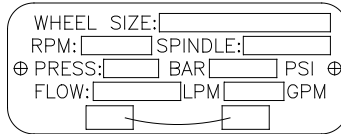

28811  
INFORMATION PLAQUE



05153  
ADDRESS DECAL  
(CE MODELS ONLY)

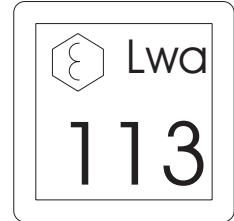

52539  
SOUND POWER DECAL  
(CE MODELS ONLY)



05868 SAFETY LABEL



28886  
COMPOSITE DECAL  
(CE MODELS ONLY)

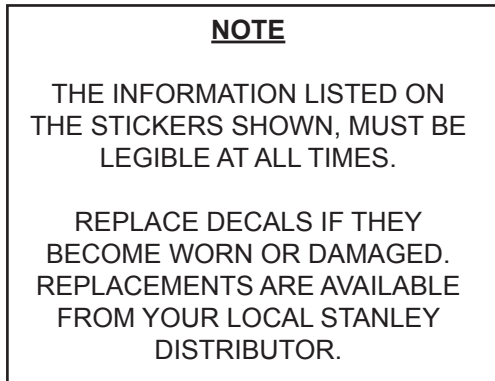

The safety tag (P/N 15875) at right is attached to the tool when shipped from the factory. Read and understand the safety instructions listed on this tag before removal. We suggest you retain this tag and attach it to the tool when not in use.

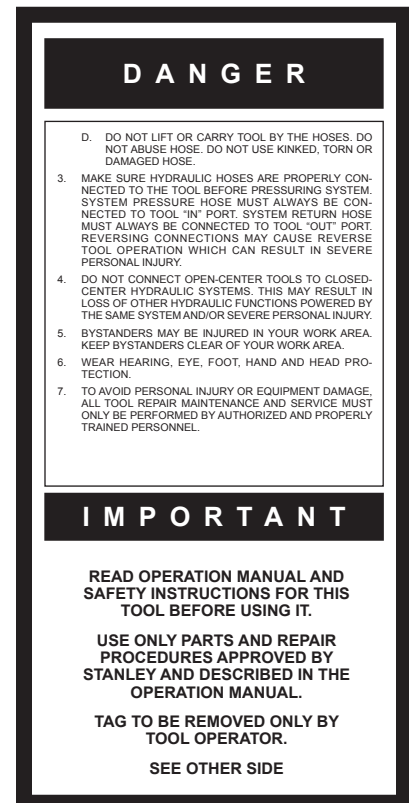
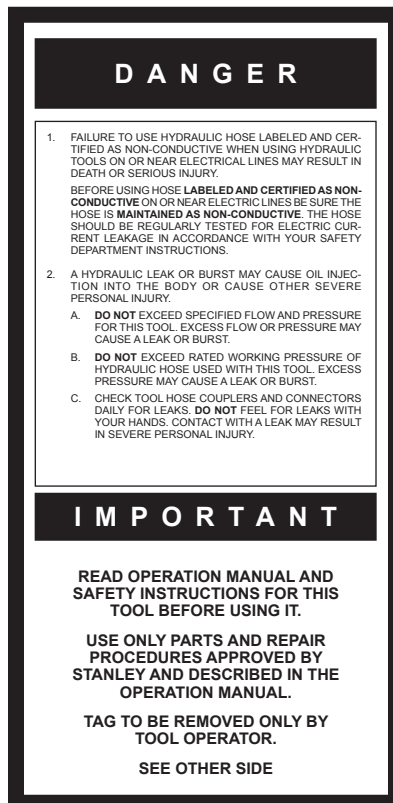

SAFETY TAG P/N 15875 (Shown smaller than actual size)



# HOSE TYPES

The rated working pressure of the hydraulic hose must be equal to or higher than the relief valve setting on the hydraulic system. There are three types of hydraulic hose that meet this requirement and are authorized for use with Stanley Hydraulic Tools. They are:

**Certified non-conductive** — constructed of thermoplastic or synthetic rubber inner tube, synthetic fiber braid reinforcement, and weather resistant thermoplastic or synthetic rubber cover. *Hose labeled **certified non-conductive** is the only hose authorized for use near electrical conductors.*

**Wire-braided** (conductive) — constructed of synthetic rubber inner tube, single or double wire braid reinforcement, and weather resistant synthetic rubber cover. *This hose is **conductive** and must never be used near electrical conductors.*

**Fabric-braided** (not certified or labeled non-conductive) — constructed of thermoplastic or synthetic rubber inner tube, synthetic fiber braid reinforcement, and weather resistant thermoplastic or synthetic rubber cover. *This hose is **not certified non-conductive** and must never be used near electrical conductors.*

## HOSE SAFETY TAGS

To help ensure your safety, the following DANGER tags are attached to all hose purchased from Stanley Hydraulic Tools. DO NOT REMOVE THESE TAGS.

If the information on a tag is illegible because of wear or damage, replace the tag immediately. A new tag may be obtained from your Stanley Distributor.

### THE TAG SHOWN BELOW IS ATTACHED TO “CERTIFIED NON-CONDUCTIVE” HOSE

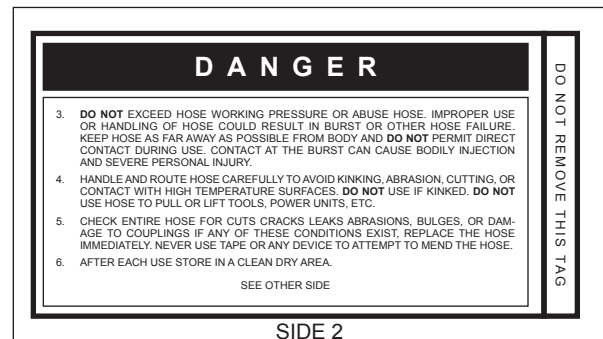
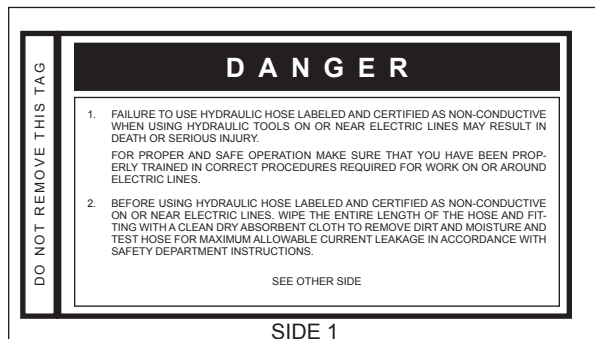

(Shown smaller than actual size)

### THE TAG SHOWN BELOW IS ATTACHED TO “CONDUCTIVE” HOSE.

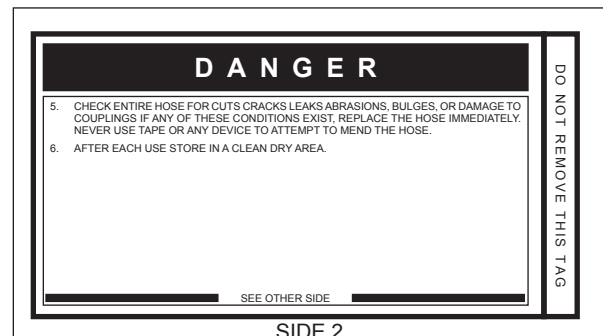
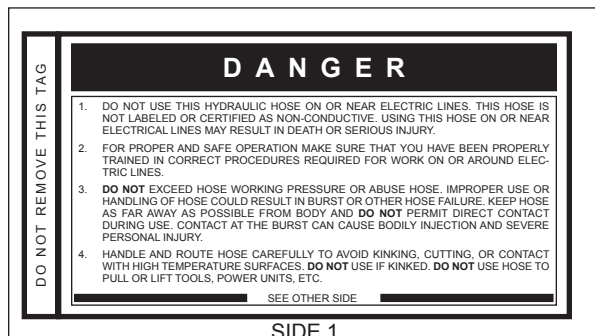

(Shown smaller than actual size)



# HOSE RECOMMENDATIONS

## Tool to Hydraulic Circuit Hose Recommendations

The chart to the right shows recommended minimum hose diameters for various hose lengths based on gallons per minute (gpm)/liters per minute (lpm). These recommendations are intended to keep return line pressure (back pressure) to a minimum acceptable level to ensure maximum tool performance.

This chart is intended to be used for hydraulic tool applications only based on Stanley Hydraulic Tools tool operating requirements and should not be used for any other applications.

All hydraulic hose must have at least a rated minimum working pressure equal to the maximum hydraulic system relief valve setting.

**All hydraulic hose must meet or exceed specifications as set forth by SAE J517.**

Oil Flow		Hose Lengths		Inside Diameter		USE (Press/Return)	Min. Working Pressure	
GPM	LPM	FEET	METERS	INCH	MM		PSI	BAR
<b>Certified Non-Conductive Hose - Fiber Braid - for Utility Bucket Trucks</b>								
4-9	15-34	up to 10	up to 3	3/8	10	Both	2250	155
<b>Conductive Hose - Wire Braid or Fiber Braid - DO NOT USE NEAR ELECTRICAL CONDUCTORS</b>								
4-6	15-23	up to 25	up to 7.5	3/8	10	Both	2500	175
4-6	15-23	26-100	7.5-30	1/2	13	Both	2500	175
5-10.5	19-40	up to 50	up to 15	1/2	13	Both	2500	175
5-10.5	19-40	51-100	15-30	5/8	16	Both	2500	175
5-10.5	19-40	100-300	30-90	5/8	16	Pressure	2500	175
10-13	38-49	up to 50	up to 15	3/4	19	Return	2500	175
10-13	38-49	51-100	15-30	5/8	16	Both	2500	175
10-13	38-49	100-200	30-60	3/4	19	Pressure	2500	175
13-16	49-60	up to 25	up to 8	5/8	16	Return	2500	175
13-16	49-60	26-100	8-30	3/4	19	Pressure	2500	175
				1	25.4	Return	2500	175
				5/8	16	Pressure	2500	175
				3/4	19	Return	2500	175
				3/4	19	Pressure	2500	175
				1	25.4	Return	2500	175

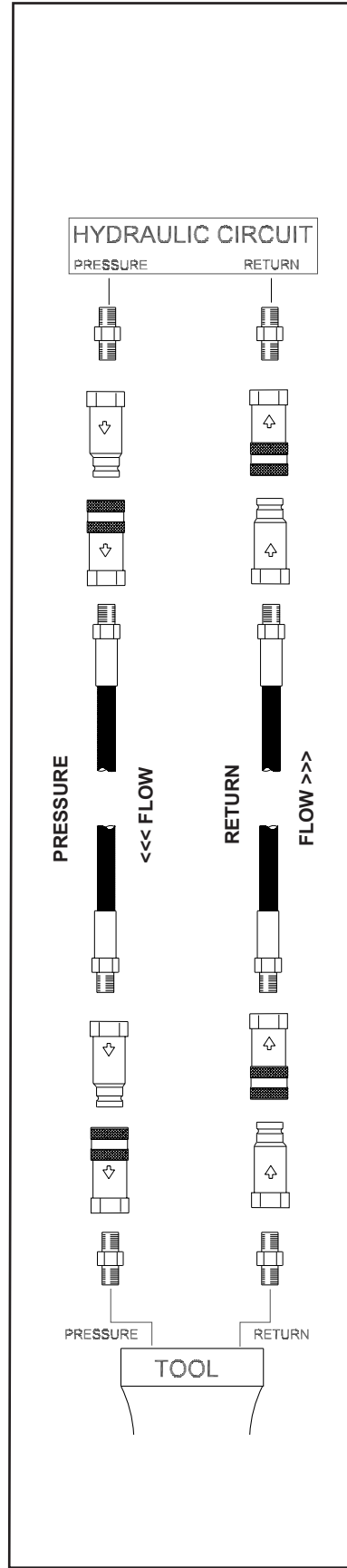

Figure 1. Typical Hose Connections

# HTMA / EHTMA REQUIREMENTS

## HTMA / EHTMA REQUIREMENTS

### HTMA

#### HYDRAULIC SYSTEM REQUIREMENTS

### TOOL TYPE

#### TYPE I

#### TYPE II

#### TYPE RR

#### TYPE III

Flow Range	4-6 gpm (15-23 lpm)	7-9 gpm (26-34 lpm)	9-10.5 gpm (34-40 lpm)	11-13 gpm (42-49 lpm)
Nominal Operating Pressure (at the power supply outlet)	1500 psi (103 bar)	1500 psi (103 bar)	1500 psi (103 bar)	1500 psi (103 bar)
System relief valve setting (at the power supply outlet)	2100-2250 psi (145-155 bar)	2100-2250 psi (145-155 bar)	2200-2300 psi (152-159 bar)	2100-2250 psi (145-155 bar)
Maximum back pressure (at tool end of the return hose)	250 psi (17 bar)	250 psi (17 bar)	250 psi (17 bar)	250 psi (17 bar)
Measured at a max. fluid viscosity of: (at min. operating temperature)	400 ssu* (82 centistokes)	400 ssu* (82 centistokes)	400 ssu* (82 centistokes)	400 ssu* (82 centistokes)
Temperature: Sufficient heat rejection capacity to limit max. fluid temperature to: (at max. expected ambient temperature)	140° F (60° C)	140° F (60° C)	140° F (60° C)	140° F (60° C)
Min. cooling capacity at a temperature difference of between ambient and fluid temps	3 hp (2.24 kW) 40° F (22° C)	5 hp (3.73 kW) 40° F (22° C)	6 hp (5.22 kW) 40° F (22° C)	7 hp (4.47 kW) 40° F (22° C)
<b>NOTE:</b> Do not operate the tool at oil temperatures above 140° F (60° C). Operation at higher temperatures can cause operator discomfort at the tool.				
Filter Min. full-flow filtration Sized for flow of at least: (For cold temp. startup and max. dirt-holding capacity)	25 microns 30 gpm (114 lpm)	25 microns 30 gpm (114 lpm)	25 microns 30 gpm (114 lpm)	25 microns 30 gpm (114 lpm)
Hydraulic fluid Petroleum based (premium grade, anti-wear, non-conductive) Viscosity (at min. and max. operating temps)	100-400 ssu*	100-400 ssu* (20-82 centistokes)	100-400 ssu*	100-400 ssu*
<b>NOTE:</b> When choosing hydraulic fluid, the expected oil temperature extremes that will be experienced in service determine the most suitable temperature viscosity characteristics. Hydraulic fluids with a viscosity index over 140 will meet the requirements over a wide range of operating temperatures.				
*SSU = Saybolt Seconds Universal				

### EHTMA HYDRAULIC SYSTEM REQUIREMENTS

### CLASSIFICATION



Flow Range	3.5-4.3 gpm (13.5-16.5 lpm)	4.7-5.8 gpm (18-22 lpm)	7.1-8.7 gpm (27-33 lpm)	9.5-11.6 gpm (36-44 lpm)	11.8-14.5 gpm (45-55 lpm)
Nominal Operating Pressure (at the power supply outlet)	1870 psi (129 bar)	1500 psi (103 bar)	1500 psi (103 bar)	1500 psi (103 bar)	1500 psi (103 bar)
System relief valve setting (at the power supply outlet)	2495 psi (172 bar)	2000 psi (138 bar)	2000 psi (138 bar)	2000 psi (138 bar)	2000 psi (138 bar)

**NOTE:** These are general hydraulic system requirements. See tool specification page for tool specific requirements

# OPERATION

## PREOPERATION PROCEDURES

### CHECK THE POWER SOURCE

Careful inspection of the tool and hydraulic system before startup is important for safe, reliable operation of the tool.

1. Using a calibrated flowmeter and pressure gauge, check that the hydraulic power source develops a flow of 7–9 gpm (26–34 lpm) at 2000 psi (140 bar).
2. Make certain the hydraulic power source is equipped with a relief valve set to open at 2100–2250 psi (145–155 bar).

### CHECK THE TOOL

The following items should be checked daily.

Make sure the hydraulic system control valve is in the “OFF” position and the hoses are disconnected before inspecting the cutoff saw.

1. Inspect the cut-off wheel and guard. Make sure the correct cut-off wheel is installed for the job. If not, follow the instructions for Cut-off Wheel Replacement section of this manual.
2. Inspect the wheel for chips, cracks, or other damage. For maximum tool performance, replace the wheel if it is worn or defective.
3. Inspect the wheel guard for cracks or other structural damage.
4. There should be no signs of leaks.
5. Inspect the handlebar. Make sure the handlebar is securely fastened to the cutoff saw and is clean of any oil to ensure a firm grip.

### IMPORTANT

Check the speed of the motor output shaft after every 100 hours of operation.

### CHECK TRIGGER MECHANISM

1. Inspect the trigger and safety catch. Make sure the trigger operates smoothly and is free to travel between the “ON:” and “OFF” positions.
2. Make sure the trigger is set to disengage the cut-off saw when released.

3. Check that the safety catch on the handle assembly is operating properly. It should prevent engagement of the trigger unless the catch is pressed down fully in the handle slot.

### CONNECT HOSES

1. Wipe all hose couplers with a clean, lint-free cloth before making connections.
2. Connect hoses from the hydraulic power source to the tool fittings or quick disconnects. It is good practice to connect the return hose first and disconnect it last to minimize or eliminate trapped pressure within the wrench.
3. Observe the flow indicators stamped on the valve handle assembly and the hose couplers to ensure that the flow is in the proper directions. The female couple on the tools “IN” port is the inlet (pressure) coupler.

#### Note:

**If the uncoupled hoses are left in the sun, pressure increase within the hoses can make them difficult to connect. Whenever possible, connect the free ends of hoses together.**

## TOOL OPERATION

### STARTUP

1. Move the hydraulic system control valve to the “ON” position.
2. At the beginning of each shift, or after a new wheel is installed, run the cut-off saw at operating speed for at least one minute before starting work.

### HANDHELD CONFIGURATION:

1. Press the safety catch into the handle, then slowly squeeze the trigger.
2. Run the saw at least one minute.
3. Release the trigger and safety catch.

### MOUNTED CONFIGURATION (SAW CART):

1. Make sure the lower edge of the cutoff wheel is at least 1 inch above the work surface.
2. Slowly squeeze the hand control lever.
3. Run the saw at least one minute, then release the control lever.

# OPERATION

If excessive vibration or any other defect is detected, stop the tool immediately and determine the cause. Do not use the tool until the problem is corrected.

## GENERAL OPERATION

### HANDHELD CONFIGURATION:

1. Whenever possible, clamp or hold down the work and support it securely on both sides of the cut.
2. Press the safety catch into the handle, then slowly squeeze the trigger.
3. Start the cut with the wheel rotating. Start the work gently with consistent pressure. Do not bump the saw into the workpiece.
4. Feed the wheel through the material as fast as possible without slowing the wheel rotation speed.

Cutting through the material too slowly causes heat expansion and can result in wheel “pinching” in the material. This is one of the most common causes of wheel breakage.

### MOUNTED CONFIGURATION (SAW CART):

When the cutoff saw is mounted on a saw cart, always use a motor-type hydraulic system control valve to turn the saw “ON” and “OFF”. All ports must be connected to the tank (hydraulic system reservoir) when the control valve is in neutral. Alternatively, use a direct line from the tool outlet to the tank.

## IMPORTANT

Keep all four wheels of the cart on the cutting surface at all times. Do not tip the front of the cart up during operation or while the blade is in motion.

1. Align the cut line indicator on the line to be cut.
2. Lower the blade to approximately 1/2 to 1-inch above the cutting surface. Set the depth gauge to ensure accurate cutting depth.
3. Make sure the water hose and its connections are secure and there is a steady flow of coolant water.
4. Slowly squeeze the hand control lever.
5. Slowly and safely lower the rotating blade into the cutting surface to the desired depth:

Increase the depth by turning the depth-control crank counterclockwise (CCW).

Periodically look at the depth gauge and pointer to check the actual depth of the cutting blade.

6. Move slowly and safely forward along the cutting line until the desired cut is complete. The safe forward rate depends on your blade type.

7. Release the hand control lever.

8. To raise the blade from of the cutting surface, wait until the blade comes to a complete stop in the work material.

Turn the depth-control crank clockwise (CW) until the blade clears the surface.

## WET CUTTING

1. Make sure the cutting wheel is suitable for wet cutting.
2. When shutting down a wet-cutting operation:
  - a. Stop the tool.
  - b. Shut off the water.

Restart the tool and allow the wheel to spin off the excess water.

## BROKEN CUT-OFF WHEELS

Cut-off wheels designed for use with portable saws are extremely tough. When used as directed, they are difficult to break during normal use.

If a wheel breaks while operating the cut-off saw, investigate the cause of the failure and correct the problem as soon as possible. If you cannot determine the cause of failure, contact the wheel manufacturer.

## SHUTDOWN

1. Move the hydraulic system control valve to the “OFF” position.
2. Disconnect the hydraulic hoses from the tool (first the input (supply) hose, then the output (return) hose).
3. Place dust plugs in the hose ends, couplers or tool ports, as applicable.
4. Wipe the tool thoroughly with a clean dry cloth.
5. Clean any foreign matter from the cut-off wheel surfaces.

# OPERATION

## PERIODIC MAINTENANCE

For maximum performance and reliability of the tool, periodically check the following components.

### THRUST COLLAR AND INSIDE/OUTSIDE COLLAR INSPECTION

Periodically inspect the thrust collar for damage when you remove the cut-off wheel (refer to Cutoff Wheel Replacement).

1. Remove the key and thrust collar from the motor shaft.
2. Check the thrust collar for burrs. Remove burrs as required.
3. Check the threads on the clamping setscrew.
4. Inspect the collar bores and flanges.
5. Check for burrs. Remove burrs as required.
6. Check that the bearing surfaces are flat and run true when mounted on the motor shaft and thrust collar.

### DRIVE-SHAFT SPEED CHECK

Check the speed of the motor output shaft at least every 100 hours of operation. The test should be performed only by a trained, experienced technician.

- Maintain a record of the speed checks.
- The maximum rated speed of the CO25 Hydraulic Cutoff Saw is 4500 rpm.
- The rated speed of the cutting wheel must be equal to, or greater than that of the tool to ensure the integrity of the wheel at maximum tool speed.
- Use the hydraulic power supply normally used with the cutoff saw when conducting this test.
- Excessive speed may be caused by excessive hydraulic fluid flow to the tool.

### BEARING CHECK

Periodically inspect the bearings and associated parts for proper operation. A worn or damaged bearing can cause motor damage.

## CARE AND STORAGE

Remove the cutoff wheel from the tool after use. Do not store or transport the saw with the wheel installed. Clean and inspect the wheel and tool before storing.

### CUTOFF WHEELS

All abrasive cutoff wheels are breakable. Exercise care in handling and storage to prevent damage.

1. Clean used wheels to remove any dirt, debris, or grease. Dry thoroughly.
2. Inspect the wheel for chips, cracks, or other damage. For maximum tool performance, replace the wheel if it is worn or defective.
3. Store cutoff wheels on a flat surface of steel or similar rigid material.
4. If wheels are supplied with blotters attached, insert suitable separators between each wheel and the supporting surface to preserve flatness.
5. Do not store wheels where they will be exposed to high humidity, water or other liquids, excessive heat, or freezing temperatures.
6. Avoid temperatures low enough to cause condensation on the wheels if they are moved from storage to an area of higher temperature.
7. Wheels carried on emergency vehicles should be removed after use, and discarded or stored carefully (steps 1 and 2).

### TOOL

1. Clean the tool to remove any dirt, debris, or grease. Dry with compressed air or clean dry cloths.
2. Replace any damaged or missing safety labels and tags before storing the tool. Otherwise, the tool might be improperly used by someone who is not familiar with the safety requirements.
3. Store the tool in a clean, dry place.

# OPERATION

## CUTOFF WHEEL REPLACEMENT

1. Move the hydraulic system control valve to the Off position.
2. Disconnect the hydraulic hoses from the tool (first the input (supply) hose, then the output (return) hose).
3. Install the inside collar and blotter, rotate the collar to align the slot in the collar with the pin on the thrust collar.
4. The maximum rated speed of the hydraulic cutoff saw is 4500 rpm. Never install a cutoff wheel that is not rated equal to or greater than that of the tool to ensure the integrity of the wheel at the maximum tool speed.
5. Prior to installing the wheel, inspect it for chips, cracks or other damage and replace if damaged.
6. Install the outside blotter and collar, rotate the collar so that the flat on the motor shaft aligns with the flat on the outside collar.
7. Install the wheel nut using a wrench while gripping the cutoff wheel. Tighten securely.

## COLD WEATHER OPERATION

Before using the tool in cold weather, preheat the hydraulic fluid with the power unit operating at a low speed. The oil should be at or above 50°F (10°C) with a viscosity of 400 SSU (82 cs) before operating the tool.

# TOOL PROTECTION & CARE

## NOTICE

In addition to the Safety Precautions found in this manual, observe the following for equipment protection and care.

- Make sure all couplers are wiped clean before connection.
- The hydraulic circuit control valve must be in the “OFF” position when coupling or uncoupling hydraulic tools. Failure to do so may result in damage to the quick couplers and cause overheating of the hydraulic system.
- Always store the tool in a clean dry space, safe from damage or pilferage.
- Make sure the circuit PRESSURE hose (with male quick disconnect) is connected to the “IN” port. The circuit RETURN hose (with female quick disconnect) is connected to the opposite port. Do not reverse circuit flow. This can cause damage to internal seals.
- Always replace hoses, couplings and other parts with replacement parts recommended by Stanley Hydraulic Tools. Supply hoses must have a minimum working pressure rating of 2500 psi/172 bar.
- Do not exceed the rated flow (see Specifications) in this manual for correct flow rate and model number. Personal Injury and rapid failure of the internal seals may result.
- Always keep critical tool markings, such as warning stickers and tags legible.
- Tool repair should be performed by experienced personnel only.
- Make certain that the recommended relief valves are installed in the pressure side of the system.
- Do not use the tool for applications for which it was not intended.



# TROUBLESHOOTING

If symptoms of poor performance develop, the following chart can be used as a guide to correct the problem. When diagnosing faults in operation of the wrench, always check that the hydraulic power source is supplying the correct hydraulic flow and pressure to the tool as listed in the following table. Use a flow meter known to be accurate. Check the flow with the hydraulic fluid temperature at least 80° F/27° C.

PROBLEM	CAUSE	SOLUTION
Tool does not operate.	Hydraulic control valve OFF.	Turn the hydraulic system control valve ON.
	Hydraulic hoses not connected properly.	Make sure the hoses are connected and the couplers are tight.
	Hydraulic system not functioning.	Check power unit for correct flow and pressure.
	Couplers or hoses blocked.	Remove obstruction.
	Mechanical failure.	Disassemble tool and inspect for damage.
Tool operates in reverse.	Hoses connected to wrong ports on tool.	Connect input (supply) line to IN port and connect output (return) line to OUT port.
Oil leakage between motor housing and ON/OFF valve block or motor.	Oil tube o-ring failure.	Replace o-ring.
	Motor face seal failure.	Replace seal.
Trigger difficult to operate.	Hoses connected to wrong ports on tool.	Connect input (supply) line to IN port and connect output (return) line to OUT port.
	Excessive back-pressure.	If back pressure is greater than 250 psi/17 bar, correct the return line obstruction or restriction.
Saw cuts too slowly.	Wrong cut-off wheel for work material.	Use correct wheel.
	Insufficient oil flow.	Adjust oil flow to 7-9 gpm/26-34 lpm.
	Relief valve setting too low.	Adjust relief valve to 2100-2250 psi/145-155 bar.

# SPECIFICATIONS

Wheel Capacity .....	14-inch/15.6 cm
Weight .....	20 lbs/9 kg
Overall Length .....	21-inch/53 cm
Width .....	11-inch/28 cm
Pressure Range.....	1500-2000 psi/105-140 bar
Flow Range .....	7-9 gpm/26-34 lpm
Optimum Flow .....	8 gpm/30 lpm
System Type.....	Open Center, HTMA Type II
Porting.....	8 SAE O-Ring
Connect Size and Type .....	3/8-inch Male Pipe Adapter
Max Spindle Speed .....	4700 rpm

## ACCESSORIES

DESCRIPTION	PART NUMBER
14-inch Abrasive Wheel for Metal, 1-inch Arbor .....	02691
14-inch Abrasive Wheel for Masonry, 1-inch Arbor.....	02692
Diamond Blade, 14-inch Dry Cut.....	62358
Water Attachment Kit for CO25 (Includes (1) Water Hose Assy P/N-33220, (1) 9.125-inch Long Tube P/N-33226, (1)- 7.812-inch Long Tube P/N-33227, (1) Brass Adaptor P/N-35196, (3) Male 90Deg Elbow 1/4" hose barb P/N-33223, (1) Male Elbow Brass P/N-35197.....	33228
Slab Saw Cart.....	69290
Water Tank Kit for Slab Saw Cart (Includes (1) Tank Top Bracket P/N-69296, (1) Tank Bracket P/N-69542, (1) Water tank P/N-41240, (1) Needle Valve Clamp P/N-69914, (2) Capscrews P/N-32412, (9) Capscrews P/N-15476, and (11) Nuts P/N- 00719.....	69704
Handle Extension Kit (Includes- (2) Oil Tubes P/N-31945, (1) Handle Weldment P/N-34116, (1) Extension P/N-34172, (4) O-Rings P/N-00175, Hardware- (2) Lockwashers P/N-01459, (2) 3/8" Capscrews P/N-02116, (4) 5/16" Capscrews P/N- 10888 and Inst Sheet .....	34175

### SOUND POWER AND VIBRATION DECLARATION

Test conducted on CO25541, S/N 673 operated at standard 12 gpm input.....	
Measured A-weighted sound power level, Lwa (ref. 1pW) in decibels .....	109.4 dBA
Uncertainty, Kwa, in decibels.....	3 dBA
Measured A-weighted sound pressure level, Lpa (ref. 20 µPa) at operator's position, in decibels .....	101.5 dBA
Uncertainty, Kpa, in decibels .....	3 dBA
Values determined according to noise test code given in ISO 15744, using the basic standard ISO3744	NOTE-
The sum of a measured noise emission value and its associated uncertainty represents an upper boundry of the range of values which is likely to occur in measurements. ....	
Declared vibration emission value in accordance with EN 12096.....	
Measured vibration emission value: a .....	4.9 m/sec <sup>2</sup>
Uncertainty: K.....	0.14 m/sec <sup>2</sup>
Values determined according to ISO 19432:2012, ISO 5349-1,2.....	

# PARTS ILLUSTRATION

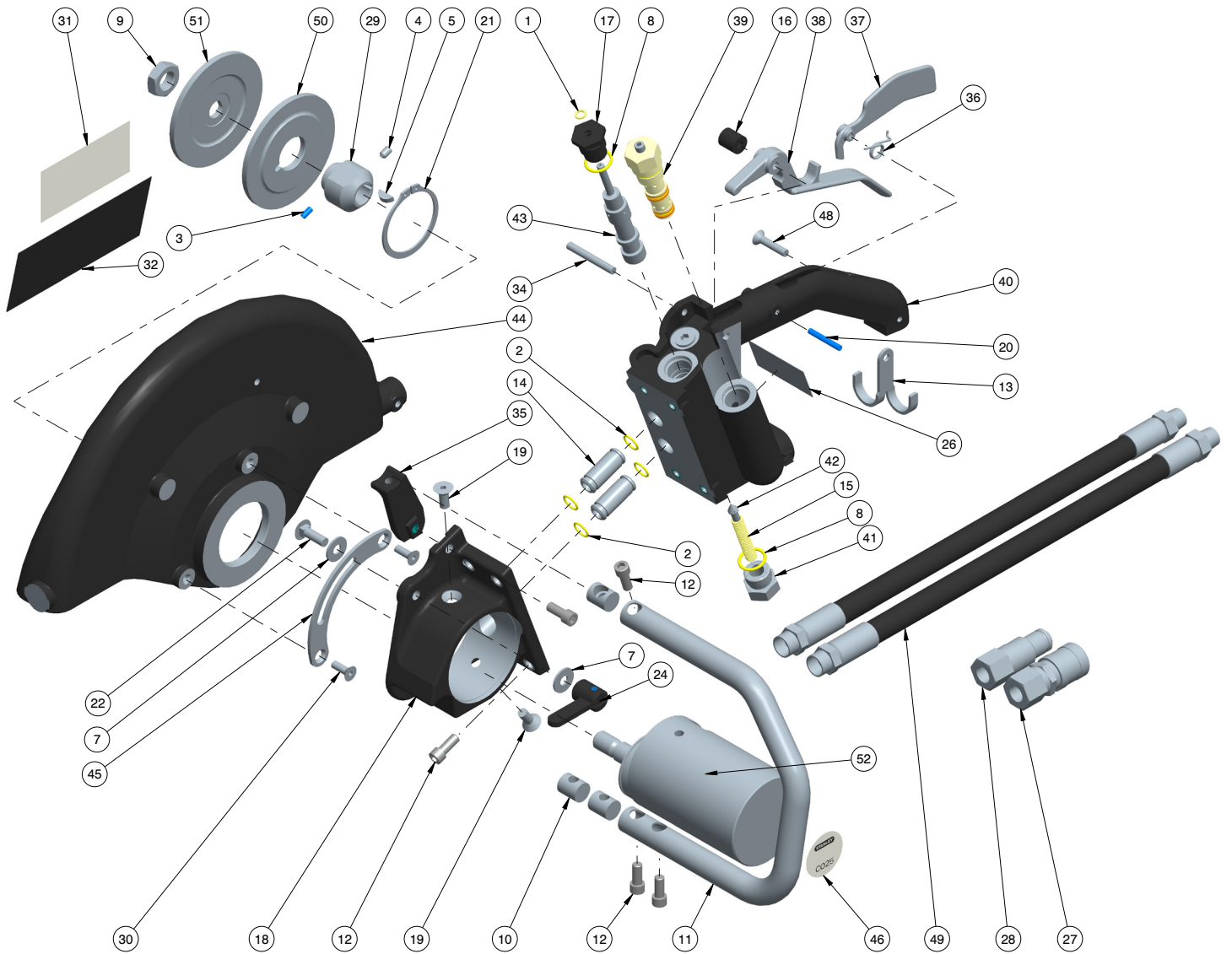

For Parts to Handle Extension Kit, See Accessories on Page 17

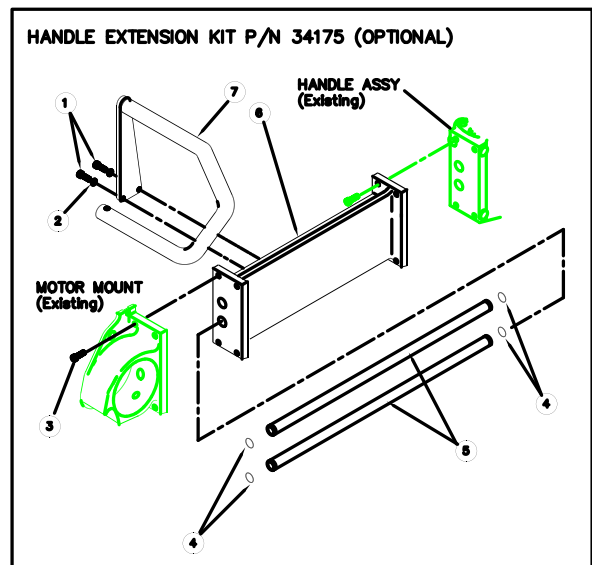

# PARTS LIST

Item No.	Part No.	Qty	Description
1	00112	1	QUAD RING*
2	00175	4	O-RING*
3	00563	1	ROLL PIN
4	00720	1	SETSCREW
5	00772	1	WOODRUFF KEY
7	01594	2	WASHER
8	01604	2	O-RING*
9	01714	1	HEX JAM NUT CCW (RH)
	03012	1	HEX JAM NUT CW (LH)
10	02649	3	HANDLE BAR RETAINER
11	02654	1	HANDLE BAR
12	02688	8	CAPSCREW
13	02911	1	HOSE CLIP
14	02912	2	OIL TUBE
15	02916	1	COMPRESSION SPRING
16	02920	1	ON-OFF VALVE SPACER
17	02931	1	ON-OFF VALVE CAP
18	02950	1	MOTOR HOUSING
19	03006	2	CAPSCREW
20	03009	1	ROLL PIN
21	03013	1	RET RING
22	03025	1	CARRIAGE BOLT
24	03050	1	SWING OVER NUT ASSY
26	03786	1	GPM STICKER
27	03972	1	COUPLER,3/8FEM.
28	03973	1	COUPLER,3/8MALE
29	04673	1	THRUST COLLAR
30	05071	2	CAPSCREW
31	05152	1	STANLEY STICKER
32	05868	1	ABRASIVE SAFETY LABEL
34	17681	1	SPRING PIN
35	20461	1	HANDLE STRUT ASSY
36	22701	1	TORSION SPRING
37	22704	1	SAFETY CATCH
38	22707	1	TRIGGER
39	25635	1	FLOW REGLTR.CRTRDG.

Item No.	Part No.	Qty	Description
40	28552	1	VALVE HANDLE ASSY (INCLUDES - SAE PLUGS)
41	31137	1	PLUG
42	31186	1	POPPET (CONE)
43	32026	1	VALVE SPOOL (CCW MODELS ONLY)
	31138	1	VALVE SPOOL (CW MODELS ONLY)
44	32436	1	WHEEL GUARD
45	32445	1	GUARD CLAMP SECTOR
46	33206	1	NAME TAG STICKER - CO25
48	35963	1	SCREW, OVAL HEAD
49	56725	2	HOSE ASSY RAILROAD 18"
50	62290	1	INSIDE COLLAR
51	62291	1	OUTSIDE COLLAR
52	33084	1	MOTOR ASSY CO25 CCW ROTATION
	33083	1	MOTOR ASSY CO25 CW ROTATION
	31845	1	SEAL KIT

• Denotes Part in Seal Kit

Coupler Set P/N-03971

Additional decals for CE tools can be found on page 7.

# STANLEY®

Stanley Hydraulic Tools  
3810 SE Naef Road  
Milwaukie, Oregon 97267-5698 USA  
(503) 659-5660 / Fax (503) 652-1780  
[www.stanleyhydraulics.com](http://www.stanleyhydraulics.com)