

# LABOUNTY®

## OPERATOR'S MANUAL



### HDR UNIVERSAL GRAPPLE

HDR210, HRD250, HDR350, HDR450

*for Pin-on or Coupler Excavators*

SERIAL NUMBER: \_\_\_\_\_

MODEL NUMBER: \_\_\_\_\_

Manual Number: 520866

Date: June 2024

Rev. 3



# Table of Contents



|   |           |
|---|-----------|
| <b>PREFACE</b> .....                    | <b>5</b>  |
| <b>SAFETY STATEMENTS</b> .....          | <b>6</b>  |
| <b>GENERAL SAFETY PRECAUTIONS</b> ..... | <b>6</b>  |
| <b>DECALS</b> .....                     | <b>13</b> |
| General Information.....                | 13        |
| <b>NOMENCLATURE</b> .....               | <b>15</b> |
| Glossary of terms .....                 | 16        |
| <b>INSTALLATION</b> .....               | <b>17</b> |
| General Information.....                | 17        |
| Coupler Installation.....               | 17        |
| Pin-On Installation.....                | 18        |
| Detaching.....                          | 21        |
| <b>OPERATION</b> .....                  | <b>23</b> |
| Intended Use.....                       | 23        |
| Attachment Controls .....               | 23        |
| Getting The Feel Of The Attachment..... | 24        |
| Operating Tips .....                    | 24        |
| Mounting Positions .....                | 24        |
| Storage.....                            | 26        |
| Removal From Storage .....              | 26        |
| Lift Points.....                        | 26        |
| Tie Down Points.....                    | 27        |
| Transporting.....                       | 27        |
| <b>LUBRICATION</b> .....                | <b>28</b> |
| Lubrication .....                       | 28        |
| <b>MAINTENANCE</b> .....                | <b>29</b> |
| General Information.....                | 29        |
| Tine Tip Maintenance .....              | 30        |
| Build Up & Hardsurfacing .....          | 31        |
| <b>MAINTENANCE</b> .....                | <b>32</b> |
| Tines & Tips Build Up.....              | 32        |
| Tines & Tips Hardsurfacing .....        | 33        |
| <b>TOOL DISPOSAL</b> .....              | <b>34</b> |
| <b>SPECIFICATIONS</b> .....             | <b>36</b> |
| <b>BOLT TORQUE SPECIFICATIONS</b> ..... | <b>37</b> |
| <b>PARTS</b> .....                      | <b>39</b> |
| <b>WARRANTY</b> .....                   | <b>39</b> |



**THIS PAGE  
IS INTENTIONALLY  
BLANK**

# Preface



## General Comments

Congratulations on the purchase of your new product! This product was carefully designed and manufactured to give you many years of dependable service. Only minor maintenance (such as cleaning and lubricating) is required to keep it in top working condition. Be sure to observe all maintenance procedures and safety precautions in this manual and on any safety decals located on the product and on any equipment on which the product is used with.

This manual has been designed to help you do a better, safer job. Read this manual carefully and become familiar with its contents.



### **WARNING!**

**Never let anyone operate this unit without reading the “Safety Precautions” and “Operating Instructions” sections of this manual.**

Unless noted otherwise, right and left sides are determined from the operator’s control position when facing forward.

### **IMPORTANT**

**The illustrations and data used in this manual were current (according to the information available to us) at the time of printing, however, we reserve the right to redesign and change the product as may be necessary without notification.**

## Before Operation

The primary responsibility for safety with this equipment falls to the operator. Make sure the equipment is operated only by trained individuals that have read and understand this manual. If there is any portion of this manual or function you do not understand, contact your local authorized dealer or the manufacturer to obtain further assistance. Keep this manual available for reference. Provide the manual to any new owners and/or operators.



### **Safety Alert Symbol**

This is the “Safety Alert Symbol” used by this industry. This symbol is used to warn of possible injury. Be sure to read all warnings carefully. They are included for your safety and for the safety of others working with you.

## Service

Use only manufacturer replacement parts. Substitute parts may not meet the required standards.

Record the model and serial number of your unit on the cover of this manual. The parts department needs this information to insure that you receive the correct parts.

## Sound And Vibration

Sound pressure levels and vibration data for this attachment are influenced by many different parameters: some items are listed below (not inclusive):

- ▶ prime mover type, age, condition, with or without cab enclosure and configuration
- ▶ operator training, behavior, stress level
- ▶ job site organization, working material condition, environment

Based on the uncertainty of the prime mover, operator, and job site, it is not possible to get precise machine and operator sound pressure levels or vibration levels for this attachment.

# Safety Statements



THIS SYMBOL BY ITSELF OR WITH A WARNING WORD THROUGHOUT THIS MANUAL IS USED TO CALL YOUR ATTENTION TO INSTRUCTIONS INVOLVING YOUR PERSONAL SAFETY OR THE SAFETY OF OTHERS. FAILURE TO FOLLOW THESE INSTRUCTIONS CAN RESULT IN INJURY OR DEATH.



## **DANGER!**

INDICATES A HAZARDOUS SITUATION WHICH, IF NOT AVOIDED, WILL RESULT IN DEATH OR SERIOUS INJURY



## **WARNING!**

INDICATES A HAZARDOUS SITUATION WHICH, IF NOT AVOIDED, COULD RESULT IN DEATH OR SERIOUS INJURY



## **CAUTION!**

INDICATES A HAZARDOUS SITUATION WHICH, IF NOT AVOIDED, COULD RESULT IN MINOR OR MODERATE INJURY

## **NOTICE**

NOTICE IS USED TO ADDRESS PRACTICES NOT RELATED TO PHYSICAL INJURY.

# General Safety Precautions



## **WARNING!**



### **READ AND UNDERSTAND MANUAL**

- ▶ Read and understand this manual and other safety information provided with this equipment and base machine (prime mover) and be sure all controls and instructions are understood before attempting to install, operate or maintain this equipment.
- ▶ Read and follow all safety warnings and instructions.
- ▶ Do not discard safety instructions. Give to the operator.
- ▶ Improper installation, operation or maintenance of this equipment could result in serious injury, death or property damage.

### **READ AND UNDERSTAND ALL SAFETY STATEMENTS**

- ▶ Read all safety statements in this manual and on your equipment safety decals.
- ▶ Keep safety decals in good condition. Replace missing or damaged safety decals.
- ▶ Because the manufacturer cannot foresee all hazardous circumstances, the precautions listed in this manual and on the equipment are not all-inclusive. If a procedure, method, tool or part is not specifically recommended by the manufacturer, determine whether it is safe for you and others, and that the equipment will not be damaged or made unsafe as a result of your decision to implement it.

## PERSONAL PROTECTIVE EQUIPMENT (PPE)

- ▶ Always wear personal protective equipment (PPE) appropriate for the job, such as eye protection, ear protection, gloves, head protection, breathing protection and safety shoes. PPE should be worn at all times when operating, maintaining or observing the tool.
- ▶ Use PPE that conforms to standards ANSI Z87.1 (Eye and Face Protection), ANSI Z89.1 (Head Protection), ANSI Z41.1 (Foot Protection) and ANSI S12.6 (S3.19) (Hearing Protection).
- ▶ Do not wear loose fitting clothing, jewelry, long hair or gloves with cut or frayed fingers. These items can become entangled in the equipment causing hazards such as choking, scalping, lacerations, severed or broken appendages.



M003  
Wear Ear  
Protection



M004  
Wear Eye  
Protection



M016  
Wear a Mask

## KNOW YOUR EQUIPMENT

- ▶ Know your equipment's capabilities, dimensions, and controls before operating.
- ▶ Do not operate a damaged, improperly adjusted, modified or incompletely assembled tool.
- ▶ Make sure all safety guards and devices are installed.
- ▶ Check all hardware to ensure it is tight.
- ▶ Make certain that all locking pins, latches, and connection devices are properly installed and secured.
- ▶ Remove and replace any damaged, fatigued, or excessively worn parts.
- ▶ Inspect the tool before each use and ensure all safety decals are in place and legible. Contact manufacturer if replacement decals are needed.
- ▶ Know and follow good work practices when assembling, maintaining, repairing, mounting, removing or operating this equipment.

## SAFELY OPERATE EQUIPMENT

- ▶ Establish a training program for all operators to ensure safe operation.
- ▶ Do not operate the tool unless thoroughly trained or under the supervision of a qualified operator or instructor.
- ▶ Know and obey all OSHA regulations, local laws, and other professional guidelines for your operation.
- ▶ Know your work site safety rules. When in doubt on any safety issue, contact your supervisor or safety coordinator.
- ▶ Assess hazards to yourself and others around you before operating the tool. Start in a work area without bystanders. A hazard to bystanders can include, but is not limited to, the risk of serious injury or death caused by the tool or accessories being dropped from an elevated height. Keep children out of the work area.
- ▶ Do not operate the equipment from anywhere other than the correct operator's position.
- ▶ Do not alter or remove any safety feature from the prime mover or tool.
- ▶ Stay alert, watch what you are doing and use common sense when operating the tool. Do not operate the tool if you are tired or under the influence of drugs, alcohol or medication. A moment of inattention while operating the tool may result in serious injury.

# General Safety

## Precautions



### CALIFORNIA PROPOSITION 65 WARNING

- ▶ This product may contain a chemical known to the State of California to cause cancer, or birth defects or other reproductive harm. [www.P65Warnings.ca.gov](http://www.P65Warnings.ca.gov)

### DUST AND FUMES

- ▶ **WARNING:** Dust created by power sanding, sawing, grinding, drilling, and other job site activities may contain chemicals known to cause cancer, birth defects or other reproductive harm. Some examples of these chemicals are:

- Lead from lead-based paints
- Crystalline silica from quartz, bricks, cement and other masonry products
- Arsenic and chromium from chemically-treated lumber

- ▶ To reduce your exposure to these chemicals: work in a well ventilated area and work with approved safety equipment, such as dust masks that are specially designed to filter out microscopic particles. Protect yourself and those around you.
- ▶ Research and understand materials you are working with.
- ▶ Follow correct safety procedures and comply with all applicable national, state or provisional health and safety regulations relating to them, including, if appropriate, arranging for the safe disposal of the materials by a qualified person.
- ▶ Use dust suppression or dust collection methods when using a tool that may cause high levels of dust.
  - Control dust or fumes at the point of emission.
  - Direct tool exhaust to minimize disturbance of dust.
  - Operate and maintain the tool as recommended in this manual to minimize dust.
  - Use respiratory protection in accordance with employers instruction or as required by occupational health and safety regulations.
  - Avoid prolonged contact with dust. Allowing dust to get into your mouth, eyes or on the skin may promote absorption of harmful chemicals.



### SAFELY MAINTAIN AND REPAIR EQUIPMENT

- ▶ Work in a clean and dry area.
- ▶ Keep the work area well lit.
- ▶ Work on a level surface.
- ▶ Use properly grounded electrical outlets and tools.
- ▶ Use the correct tools for the job at hand.
- ▶ Ensure tools are working properly and safely by performing preventative maintenance procedures.
- ▶ Wear protective equipment specified by the tool manufacturer.
- ▶ Do not perform any work on the tool unless you are authorized and qualified to do so. Always read the operator service manuals before any repair is made.
- ▶ After completing maintenance or repair, remove all maintenance tools and unused parts from equipment.



- ▶ Check for correct operation of the tool. If not operating properly, shut down the prime mover, follow proper Lock-Out / Tag-Out procedures and tag “DO NOT OPERATE” until all problems are corrected.

### **USE CARE WITH HYDRAULIC FLUID PRESSURE**

- ▶ **DO NOT** attempt to make repairs to hydraulic lines or components while the system is pressurized. Hydraulic fluid under pressure can penetrate the skin and cause serious injury or death. Follow proper procedures for relieving pressure from hydraulic system before connecting or disconnecting hydraulic lines or components.
- ▶ Wear personal protective equipment (PPE) such as safety glasses, gloves and protective clothing at all times.
- ▶ Hydraulic leaks under pressure may not be easily visible. Keep hands and other body parts away from a suspected leak. Flesh injected with hydraulic fluid may develop gangrene or other permanent disabilities. Use a piece of cardboard or wood when searching for hydraulic leaks.
- ▶ If injured by injected fluid, seek immediate medical attention.
- ▶ Hydraulic fluid can become hot during operation. **DO NOT** come in contact with hot hydraulic fluid as it could cause severe burns.
- ▶ If exposed to hydraulic fluid, wash hands immediately.
- ▶ Inspect and clean couplers before use. Replace damaged couplers immediately.
- ▶ Ensure the couplers are properly connected and are tight.
- ▶ Do not smoke while working on the hydraulic system.



### **DO NOT MISUSE OR MODIFY EQUIPMENT**

- ▶ Use and maintain the tool as stated in this manual. Misuse of the tool can cause serious injury.
- ▶ Do not modify the tool in any way. Modifications may weaken its integrity and may impair its function, safety, life and performance. When making repairs use only factory recommended replacement parts, following authorized instructions. Use of parts that are not factory approved may be substandard in fit and quality and may cause damage and void the warranty.
- ▶ Do not modify any ROPS (Roll Over Protective Structure) or FOPS (Falling Object Protective Structure) equipment or device. Any modifications must be authorized in writing by the manufacturer.

### **END OF LIFE DISPOSAL**

- ▶ At the completion of the useful life of the unit, drain all fluids and dismantle by separating the different materials (rubber, steel, plastic, etc.). Follow all federal, state and local regulations for recycling and disposal of the fluid and components.

# Equipment Safety

## Precautions



### **WARNING!**

#### **REMOVE PAINT BEFORE WELDING OR HEATING**

Hazardous fumes/dust can be generated when paint is heated by welding, soldering or using a torch. Do all work outside or in a well ventilated area and dispose of paint and solvent properly. Remove paint before welding or heating.

When sanding or grinding paint, avoid breathing the dust. Wear an approved respirator. If you use solvent or paint stripper, remove stripper with soap and water before welding. Remove solvent or paint stripper containers and other flammable material from area. Allow fumes to disperse at least 15 minutes before welding or heating.

#### **PROTECT AGAINST FLYING DEBRIS**

Always wear proper safety glasses, goggles, or a face shield when driving pins in or out, or when any operation causes dust, flying debris, or any other hazardous material.

#### **LOWER OR SUPPORT RAISED EQUIPMENT**

Do not work under raised booms without supporting them. Do not use support material made of concrete blocks, logs, buckets, barrels, or any other material that could suddenly collapse or shift positions. Make sure support material is solid, not decayed, warped, twisted, or tapered. Lower booms to ground level or on blocks. Lower booms and attachments to the ground before leaving the cab or operator's station.

#### **OPERATING THE ATTACHMENT**

- ▶ Clear all persons and equipment from the area of operation and machine movement. NEVER move loads over people or equipment. When viewing the operation of the attachment, maintain a safe distance of at least 30 feet (9 meters).
- ▶ DO NOT operate towards people, livestock or where property damage can occur. Keep children and others away from operating area.
- ▶ NEVER leave the attachment suspended or pass it over people, occupied vehicles or buildings.
- ▶ Use extreme caution when operating on or crossing gravel drives, walkways or roads.
- ▶ DO NOT operate without good visibility or light.
- ▶ AVOID TIPPING. The attachment will alter the lift capacities of the base machine. DO NOT overload the prime mover or serious injury could result. Lift capacities will vary if the prime mover is not on level ground. Lifting incorrectly can cause severe injury or machine damage. Use the recommended prime mover counterweight. Use short slings and lift the load only as high as necessary.
- ▶ When operating on slopes, drive up and down, not across. Avoid steep hillside operation, which could cause the prime mover to overturn.
- ▶ Reduce speed when driving over rough terrain, on a slope, or turning, to avoid overturning the vehicle.
- ▶ Operate only from the operator's station.



## **WARNING!**

- ▶ Ensure that the cab is equipped with the proper safety guards for LaBounty applications. The cab **MUST** be equipped with an approved Falling Object Protection Structure (FOPS). The FOPS must meet the requirements of SAE standard J1356. A transparent, shatter-resistant shield covering the front of the cab, is also required. Contact your prime mover dealer or manufacturer for more information on the availability of FOPS. Lack of proper FOPS may result in injury or death.
- ▶ **USE CAUTION** when curling the prime mover stick in toward the boom while the grapple is in the operating position. If the grapple contacts the prime mover, damage to the grapple and/or prime mover may occur.
- ▶ **DO NOT** process material with the attachment over the operator's cab. Doing so will result in severe personal injury or death from falling debris.
- ▶ **DO NOT** operate equipment if tired or under the influence of drugs or alcohol, which can impair alertness or coordination. A person taking prescription or over-the-counter medications should seek medical advice before he or she can safely operate equipment.
- ▶ Before exiting the prime mover, lower the attachment to the ground, apply the brakes, turn off the prime mover's engine and remove the key.
- ▶ **NEVER** approach power lines with any part of the machine. Keep clear at a minimum of 15 feet (5 meters).
- ▶ **DO NOT** close the attachment on a structure and reverse the prime mover in an attempt to pull down material.
- ▶ **DO NOT** use attachment as a jack hammer or wrecking ball.
- ▶ The attachment is not a dozer. **DO NOT** position it on the ground and travel forward.

### **TRANSPORTING THE ATTACHMENT**

- ▶ Travel only with the attachment in a safe transport position to prevent uncontrolled movement. Drive slowly over rough ground and on slopes.
- ▶ When transporting on a trailer: Secure attachment at recommended tie down locations using tie down accessories that are capable of maintaining attachment stability.
- ▶ When driving on public roads use safety lights, reflectors, Slow Moving Vehicle signs etc., to prevent accidents. Check local government regulations that may affect you.
- ▶ **DO NOT** drive close to ditches, excavations, etc., cave in could result.

### **MAINTAINING THE ATTACHMENT**

- ▶ Before performing maintenance lower the attachment to the ground, apply the brakes, turn off the engine and remove the key.
- ▶ **NEVER** perform any work on the attachment unless you are authorized and qualified to do so. Always read the operator service manuals before any repair is made. After completing maintenance or repair, check for correct functioning of the attachment. If not functioning properly, shut down the machine, follow proper Lock-Out / Tag-Out procedures and tag "DO NOT OPERATE" until all problems are corrected.

# Equipment Safety

## Precautions



- ▶ Worn, damaged, or illegible safety decals must be replaced. New safety decals can be ordered from LaBounty.
- ▶ NEVER make hydraulic repairs while the system is under pressure. Serious personal injury or death could result.
- ▶ Disassembly of any pin-connected attachment can be hazardous. NEVER remove any pin unless the attachment is on the ground and blocked up. Serious injury or death could result. Metal chips or debris may fly when a connecting pin is struck. Use a brass drift when striking pins and always wear protective clothing and proper eye protection. Pins may fly when struck with force to drive them in or out. Always keep people clear when removing or installing pins.
- ▶ DO NOT weld on any structural member unless specifically authorized. Welding procedures may result in personal injury.
- ▶ NEVER work under a raised attachment.
- ▶ Stop the prime mover engine and cycle control levers to release hydraulic pressure before servicing or adjusting attachment hydraulic systems.

# Decals

## Decal Placement



### GENERAL INFORMATION

The diagrams on this page show the location of the decals used on your attachment. The decals are identified by their part numbers, with reductions of the actual decals located on the following page. Use this information to order replacements for lost or damaged decals. Be sure to read all decals before operating the attachment. They contain information you need to know for both safety and product longevity.

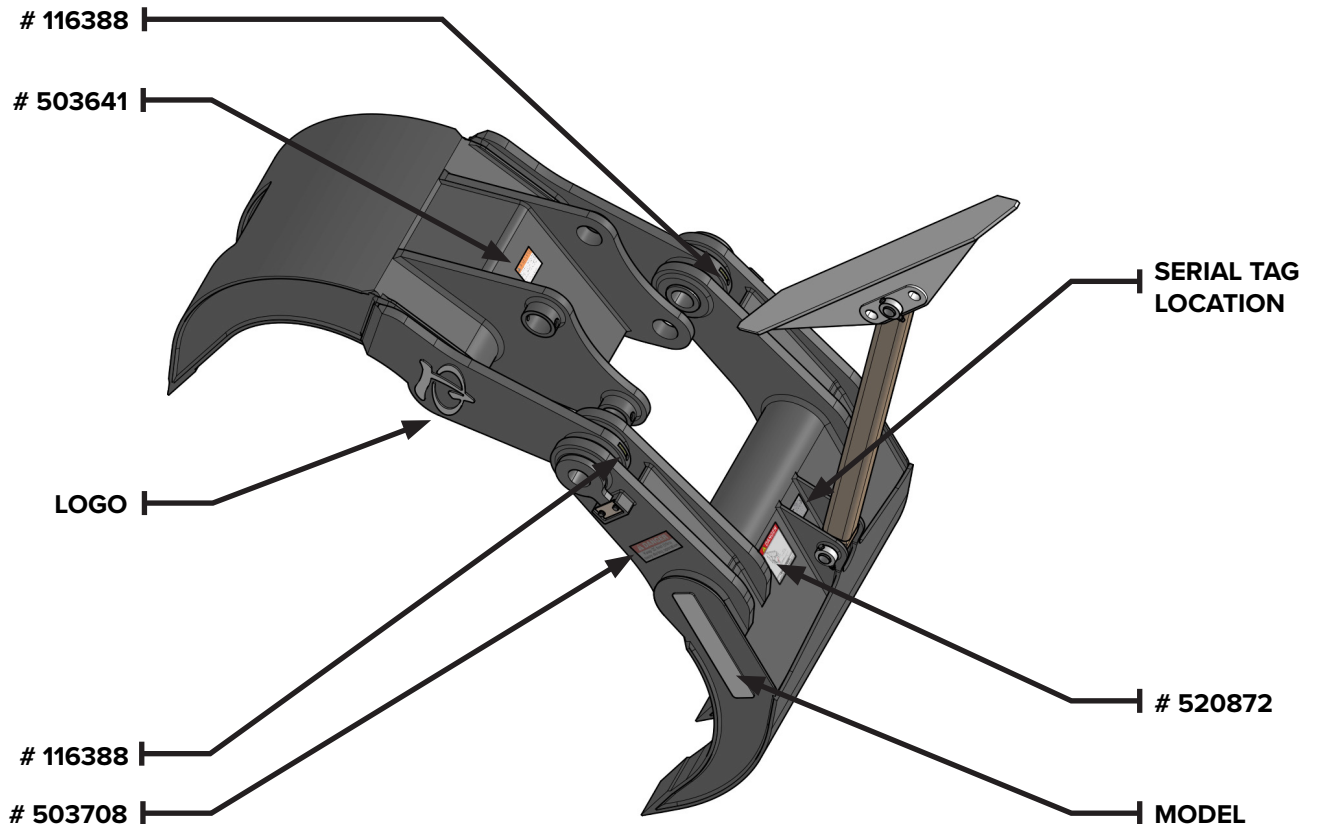

HDR210 SHOWN

### IMPORTANT

Keep all safety decals clean and legible. Replace all missing, illegible, or damaged safety decals. When replacing parts with safety decals attached, the safety decals must also be replaced. Safety decals are available, free of charge, from your local dealer or LaBounty.

**REPLACING SAFETY DECALS:** Clean the area of application with nonflammable solvent, then wash the same area with soap and water. Allow the surface to fully dry. Remove the backing from the safety decal, exposing the adhesive surface. Apply the safety decal to the position shown in the diagram above and smooth out any bubbles.

# Decals

## Decal Placement



**! CLEARANCE HAZARD !**  
Curling machine arm may cause grapple and objects in grapple jaws to contact the machine boom, cab, tracks, or other areas. Operator must use extreme caution when using tool close to machine.

**! DANGER!**  
# 520872 - CLEARANCE HAZARD! DO NOT STRIKE MACHINE.

**! DANGER**  
Keep 30 feet (10m) away during operation

**! DANGER!**  
# 503708 - KEEP 30 FEET (10 M) AWAY DURING OPERATION.

**! WARNING**  
This bracket is designed for a specific excavator size range. Consult LaBounty or a LaBounty Representative before changing carriers.  
Phone#: (833) 723-1843

503641

**! WARNING!**  
# 503641 - BRACKET IS DESIGNED FOR SPECIFIC EXCAVATORS.

**GREASE →**

# 116388 - GREASE FITTING

**NOTE** Contact your local dealer for model number and logo decals

# Nomenclature

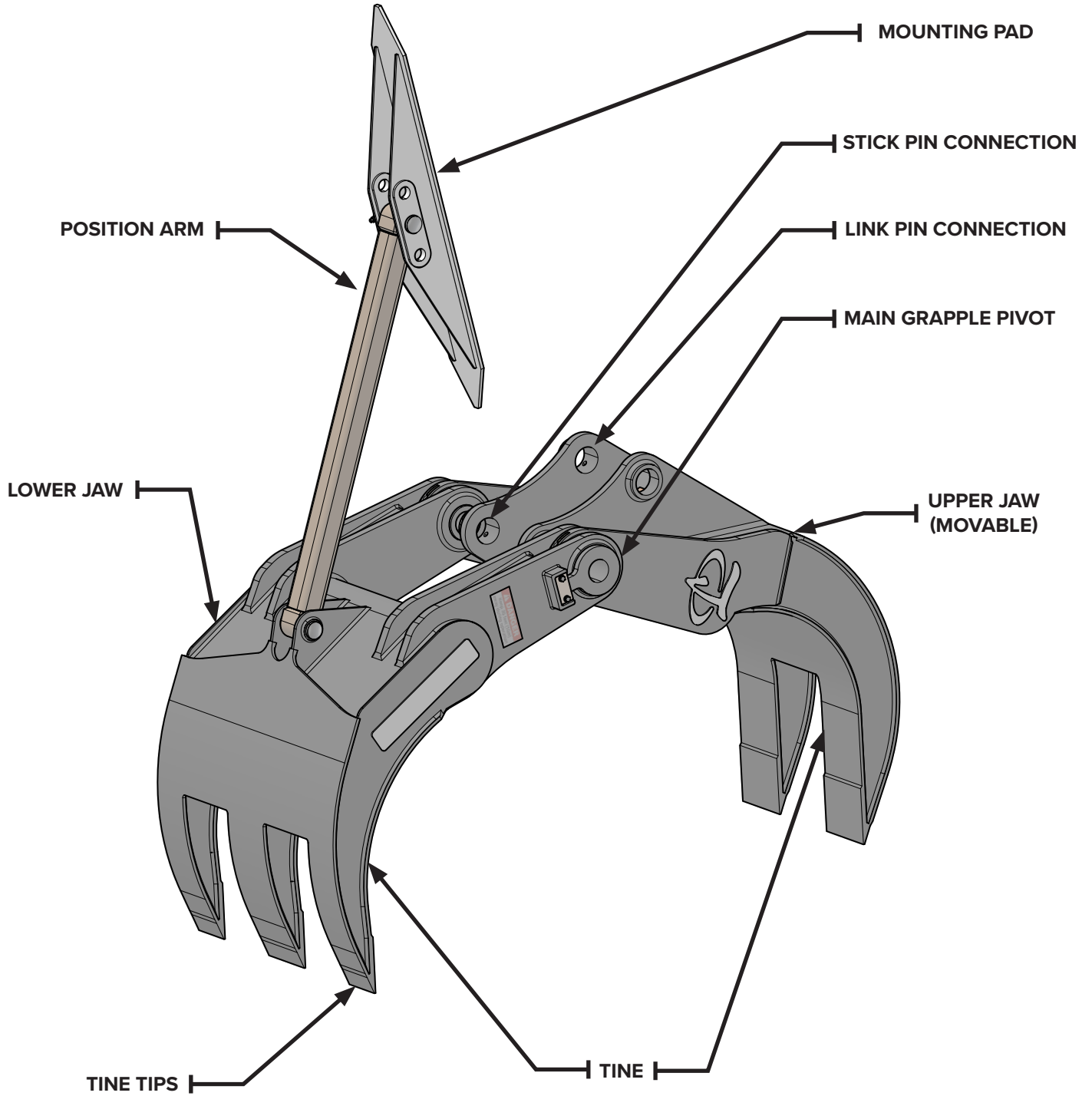

# Nomenclature



## GLOSSARY OF TERMS

|                     |   |
|---------------------|---|
| <b>Build Up</b>     | Welding process where worn off parent material is replaced with new metal. A very important maintenance procedure to extend the life of the grapple.  |
| <b>Guide Link</b>   | Part of the prime mover bucket linkage that pins at one end to the prime mover stick and pins at the other end to the bucket cylinder and the power link.   |
| <b>Hardsurface</b>  | Welding process for protecting the parent material of the grapple. The hardsurface acts as a wear surface.  |
| <b>Link Pin</b>     | The pin that connects the upper jaw of the grapple to the power link of the prime mover.  |
| <b>Lower Jaw</b>    | The lower half of the grapple that is positioned nearest to the cab and is held stationary by the position arm. <i>The lower jaw is not stationary when using a coupler.</i>  |
| <b>Main Pivot</b>   | Close tolerance area that contains the spools, and bearings and connects the two halves of the grapple.   |
| <b>Mounting Pad</b> | A bracket welded to the bottom of the prime mover stick at a specific location. The position arm pins between the mounting pad and the grapple lower jaw. The mounting pad properly positions the lower jaw and distributes stresses evenly through the stick during grapple operation. |
| <b>Position Arm</b> | A structural member pinned between the lower jaw and the mounting pad to support the lower jaw.   |
| <b>Power Link</b>   | Part of the bucket linkage that pins at one end to the upper jaw of the grapple and pins at the other end to the guide link and bucket cylinder.  |
| <b>Spool</b>        | A flanged tube that holds the two jaws together and creates a pivot for the upper jaw. There are two spools in the main pivot of a grapple.   |
| <b>Stick Pin</b>    | The pin that connects the grapple to the prime mover on the stick side.   |
| <b>Tines</b>        | The multiple “fingers” of the grapple used to pick and hold material. The lower jaw has one more tine than the upper jaw.   |
| <b>Tine Tips</b>    | The ends of the tines on the grapple. The tips can be built-up and hardsurfaced or replaced when they are worn.   |
| <b>Upper Jaw</b>    | The upper half of the grapple that turns on the main pivot and is connected to the power link side of the prime mover.  |



# Installation



## GENERAL INFORMATION

The following instructions will help you to mount your HDR Universal Grapple onto your prime mover. The grapple can be directly pinned to the stick in place of the bucket or can be attached via a quick coupler. Therefore, if you know how to attach your bucket, attaching the grapple should prove no problem. Some welding is required for initial set-up and maintenance.

Remember to read all safety warnings, decals and operating instructions before operating the attachment. If there is any portion of this manual that you do not understand, contact your dealer.

### **WARNING!**

#### **READ MANUAL PRIOR TO INSTALLATION**

Improper installation, operation, or maintenance of this equipment could result in serious injury or death. Operators and maintenance personnel should read this manual, as well as all manuals related to this equipment and the prime mover thoroughly before beginning installation, operation, or maintenance.

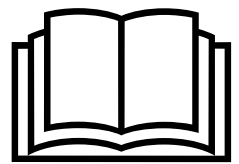

**FOLLOW ALL SAFETY INSTRUCTIONS IN THIS MANUAL AND THE PRIME MOVER'S MANUAL(S).**

### **WARNING!**

**ALWAYS PERFORM INSTALLATION AND MAINTENANCE WITH TOOL IN A SAFE POSITION. Do not attempt to assemble or disassemble the tool when in such a position that heavy components could fall and cause injury. Use a hoist or similar device to help support heavy components if needed.**

## COUPLER INSTALLATION

1. Locate flat, hard ground (e.g. concrete floor).
2. Place the grapple, tines down, on the ground and secure it. Use blocking if necessary.
3. Remove the bucket or any attachment from the arm. Follow the manufacturer's recommended procedure.
4. Following the instructions for your coupler, grab the HDR Universal Grapple with your coupler. Make sure to stay as centered as possible.
5. Proceed to Step 10 of "Mounting Pad Installation in Pin-On Installation" to finish initial installation.

### **WARNING!**

**To avoid serious personal injury, make sure the attachment is securely latched to the attachment mechanism of your unit. Failure to do so could result in separation of the attachment from the prime mover.**

# Installation



## PIN-ON INSTALLATION

1. Locate flat, hard ground (e.g. concrete floor).
2. Place the grapple, tines down, on the ground and secure it. Use blocking if necessary.
3. Remove the bucket or any attachment from the arm. Follow the manufacturer's recommended procedure.



### **WARNING!**

To avoid serious personal injury, make sure the attachment is securely latched to the attachment mechanism of your unit. Failure to do so could result in separation of the attachment from the prime mover.

4. Remove the stick pin. Bring the prime mover in position, carefully lining up the stick with the main pivot.
5. Ensure that the stick is centered between the pivots.
6. Re-assemble the stick pin to attach stick to the grapple. Install provided spacers to ensure that the excavator remains centered. See Figure #1

**FIGURE #1: EXCAVATOR STICK INSTALLATION**

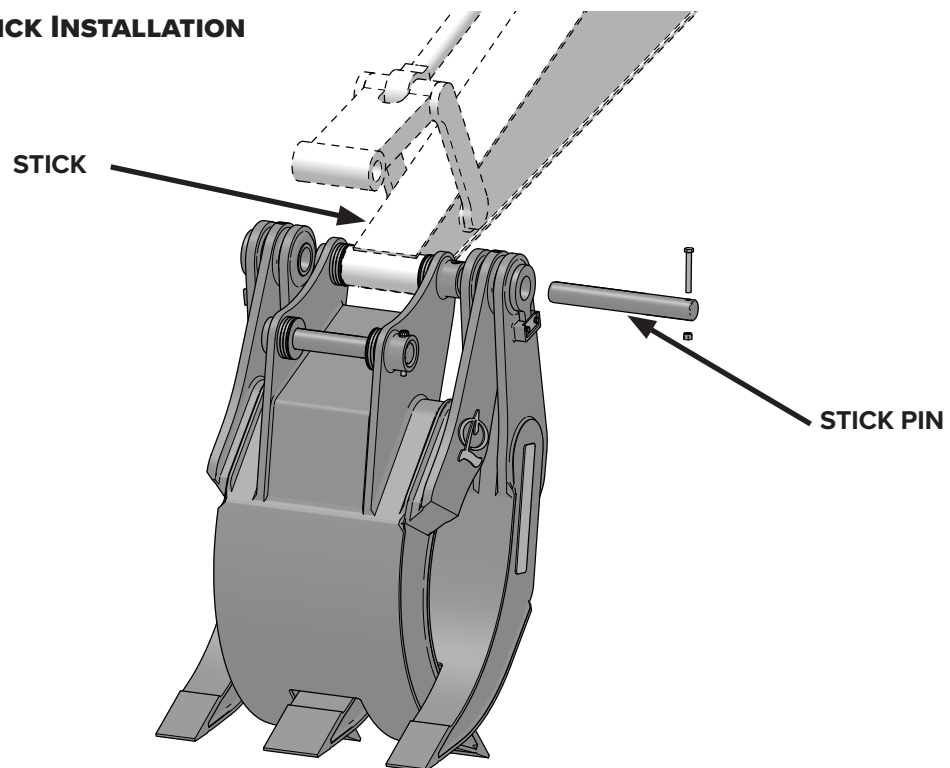

## NOTICE

**Careful centering of the excavator to the grapple when installing for the first time will allow for easier alignment of the mounting pad. LaBounty recommends measuring and calculating your stick & grapple center. Add spacers as necessary for center alignment.**

7. Remove the link pin. Carefully extend the bucket cylinder and line up the power link with the link pin connection.
8. Re-assemble the link pin. Installing provided spacers to ensure that the excavator remains centered. See Figure #2
9. Torque all nuts and bolts installed during this process to specifications. See "Bolt Torque Specifications" on page 37.

**FIGURE #2: EXCAVATOR LINKAGE INSTALLATION**

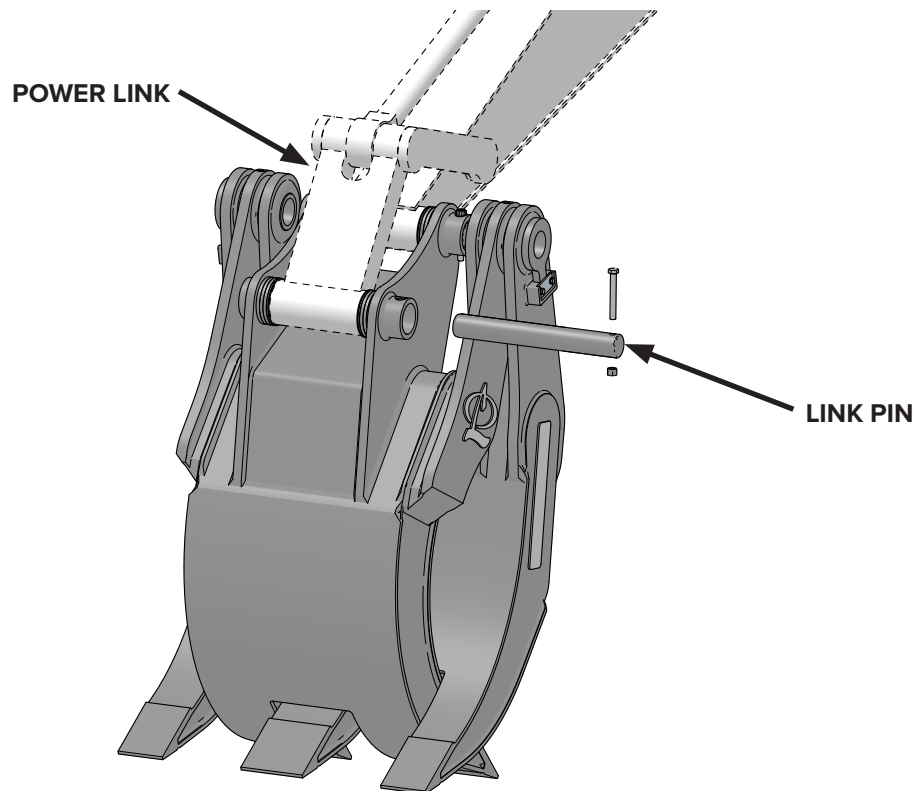

## WARNING!

Clear the area. People in the area constitute a serious safety hazard. Warn nearby workers that you are starting up. **DO NOT** start up until they are out of danger.

# Installation



## Mounting Pad Installation

10. Slowly curl the stick and extend the bucket cylinder, as shown in Figure #3.
11. Pin the position arm assembly to the lower jaw and to the mounting pad. Ensure the position arm is in the middle hole of the mounting pad. See Figure #4

### NOTE

Ensure the grease zerks on the position arm face away from the stick to allow for easier access.

FIGURE #3



FIGURE #4

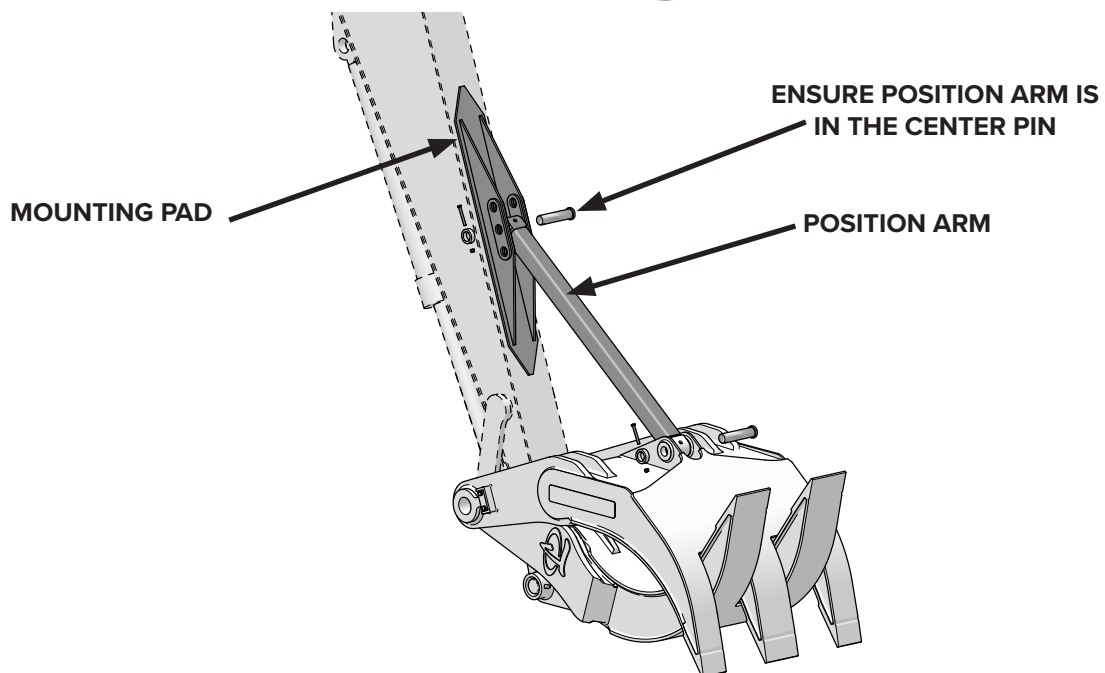

## **⚠ CAUTION!**

Wear personal protection equipment (PPE) at all times while welding. Allow only qualified, certified welders to maintain LaBounty products.

## **NOTICE!**

**DO NOT WELD ACROSS WIDTH OF PRIME MOVER'S STICK.** Always weld parallel to the long axis of the arm. Failure to do so could result in weakening of the prime mover stick.

## **NOTICE!**

**PROTECT THE SURROUNDING AREA BEFORE WELDING.** Weld spatter can cause damage to components such as pins, cylinders, hydraulic hoses and fittings, etc.

12. Position the mounting pad on the bottom of the excavator stick. Refer to the parts catalog or contact LaBounty Technical Service for proper placement details.
13. Weld the mounting pad using E7018 low hydrogen welding rod, using the following specifications:
  - ▶ 0.5" (13mm) Fillet Welds, 3" (77mm) long
  - ▶ Welds should be 6" (153mm) on center
  - ▶ Run out welds 1.5" (39mm) on the ends
  - ▶ Grind ends to a taper
  - ▶ See Figure #5 for welding diagram.
14. Cover the welded area with a heat blanket and allow to cool slowly.

## **NOTICE!**

**Do not weld around the ends of the mounting pad.** Refer to the parts catalog **or contact LaBounty Technical Service for specific mounting instructions.**

**FIGURE #5**

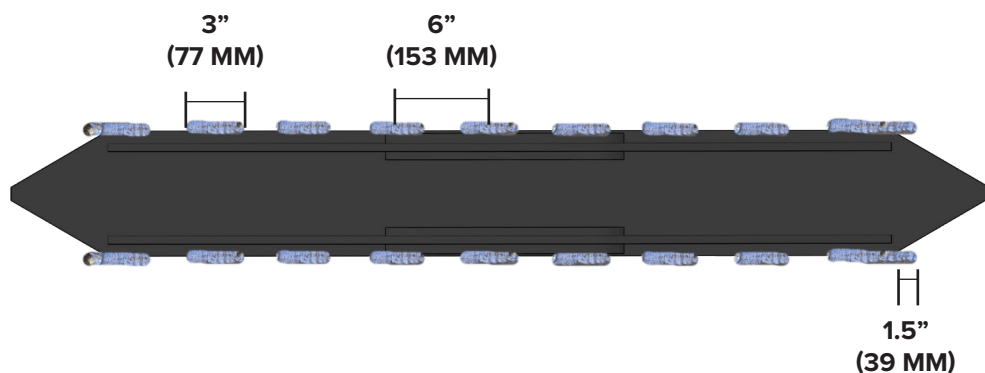

## **DETACHING**

1. Locate flat, hard ground (e.g. concrete floor).
2. Fully close the grapple and place it, tines down, on the ground. Use blocking to ensure the grapple is stable.

# Installation



3. **For Coupler Mounting Only:** Follow your coupler's instructions for detaching an attachment.
4. Turn off the excavator and Lock-out / Tag-out the hydraulic power source.
5. Support the position arm and remove the pin holding the position arm to the mounting pad. See Figure #6

**FIGURE #6**

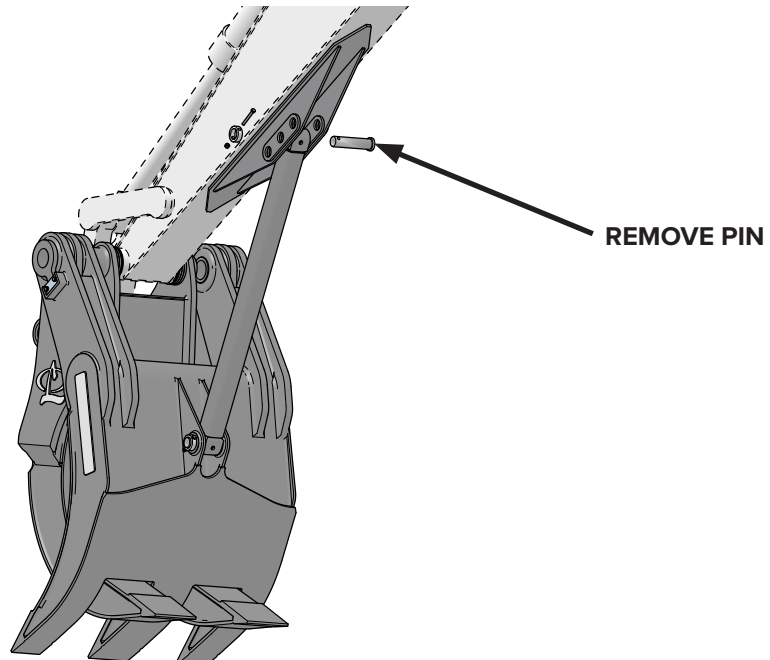

6. Remove the stick and link pins, as shown in Figure #7

**FIGURE #7**

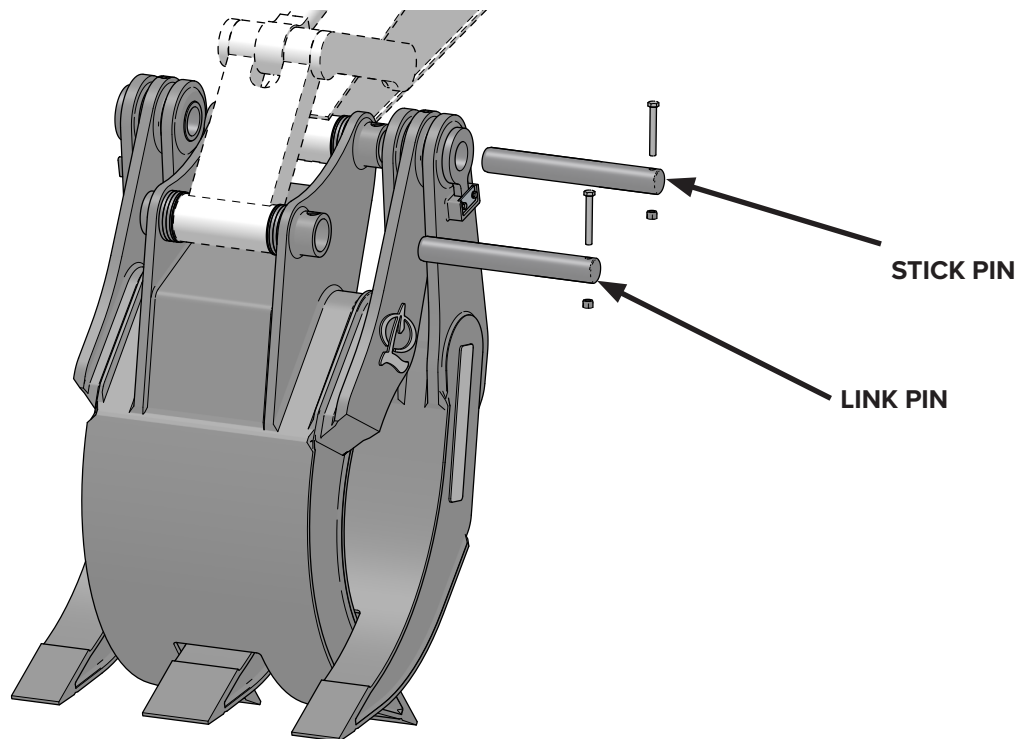

# Operation



## INTENDED USE

This HDR Universal Grapple has been designed and built for material handling in: demolition, scrap recycling, rip-rap, land clearing, log & pipe handling, and quarry applications. Use in any other way is considered contrary to the intended use. Compliance with and strict adherence to operation, service and repair conditions as specified by the manufacturer, are also essential elements of the intended use.

### **DANGER!**

**USE CAUTION** when curling the prime mover stick in toward the boom while the grapple is in the operating position. If the grapple contacts the prime mover, damage to the grapple and/or prime mover may occur.

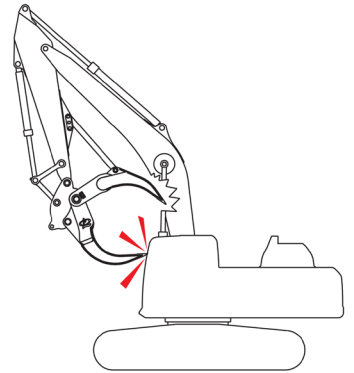

## ATTACHMENT CONTROLS

The HDR grapple replaces the bucket of an excavator and operates with the same controls—no additional hydraulics are required. The bucket dump control opens the attachment and the bucket curl control closes the attachment. See Figure #1

**FIGURE #1**

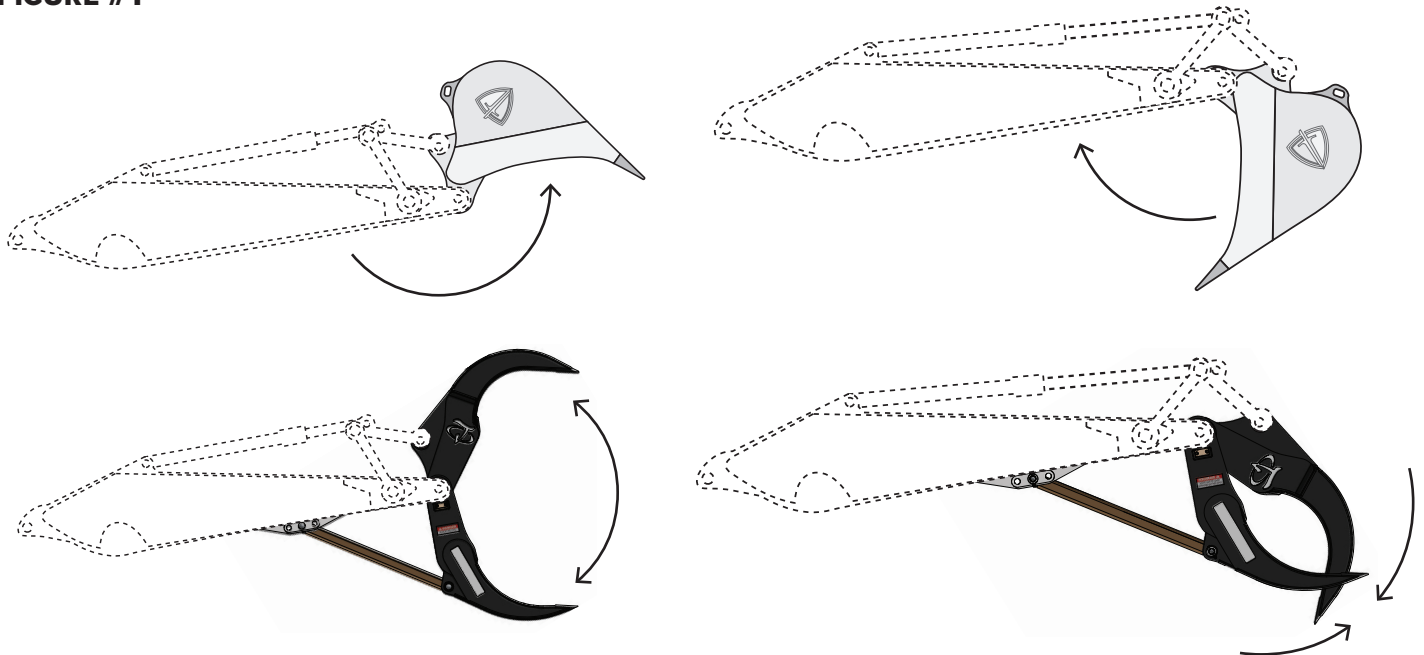

**BUCKET CURL OUT = GRAPPLE OPEN**

**BUCKET CURL IN = GRAPPLE CLOSED**

# Operation



## GETTING THE FEEL OF THE ATTACHMENT

Every part of any machine has a slightly different “operating feel”—an individual machine response to the movement of the controls. Before starting the first job with a new machine, it is suggested that the operator find an open spot on firm, level ground that is free of obstructions such as trees, buildings and other equipment—and safely away from other people. Move the machine to this area and spend some time understanding the operating feel of the machine and the grapple in order to become familiar with the control levers and grapple before beginning work.

The machine is exceedingly powerful. Do not operate carelessly; there is potential for personal injury and equipment damage. Be concerned about safety when preparing to operate the new machine. Ensure safe operation by inspecting the machine as stated in “Equipment Safety Precautions” and perform maintenance outlined in this manual.

Follow a preventive maintenance program; such a procedure will reduce the possibility of costly downtime. Read and understand the “Maintenance” section of this manual.

## OPERATING TIPS

- ▶ The control levers should be moved in a gradual, deliberate way rather than with jerky, abrupt movements.
- ▶ Understand that the attachment does have limits. Sometimes it may be necessary to downsize very large material by another method before the attachment can process it effectively.
- ▶ The mounting pad has three pin positions. See Mounting Positions.
- ▶ Always center the load between the grapple halves. Close the grapple to the fullest extent possible and lift the load slightly to be certain it is secure. DO NOT lift load high in the air and then attempt to adjust the grapple.

### NOTE

**If the load appears to be unstable, lower it to the ground, open the grapple and reposition the load to attain full stability. Repeat until full stability is achieved.**

### NOTICE!

***Because a heavy load can generate a great deal of momentum in side-to-side movements, the operator should always use caution and avoid sudden stops and starts.***

- ▶ Unload grapple from the lowest possible height. Falling loads may bounce or fly in an unexpected manner.

## MOUNTING POSITIONS

The mounting pad of a HDR Universal Grapple has three pin positions. By using the different positions, the angle of the lower grapple jaw can be adjusted (see figure #2). For each type of job, the lower jaw may be positioned to make it more productive or easier to use.

Use the following guidelines to find the best position for your current job. Some experimentation may be necessary to learn the advantages of each position.



**FIGURE #2**

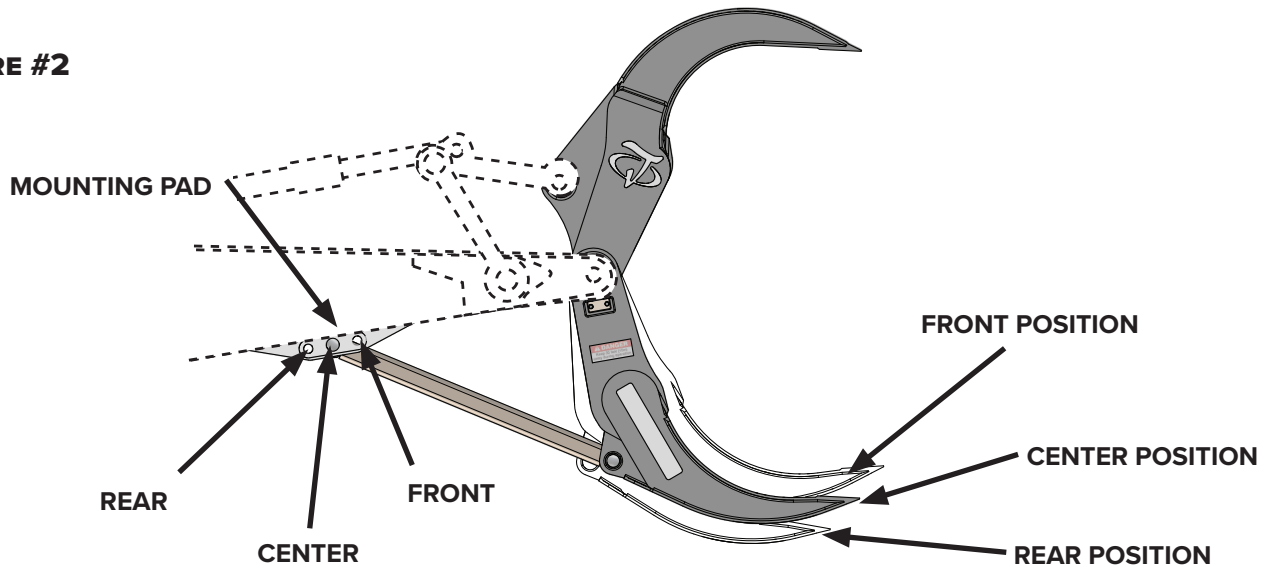

### Center Mounting Pad Position

Use the center position for general use. This will position the lower jaw to provide the best performance for a great range of uses. Some operators leave the grapple in this position for all applications.

### Rear Mounting Pad Position

Using the rear position increases the amount of grapple opening. This mounting pad position can make it easier to handle large amounts of light materials and can also make it easier to empty the grapple—as when loading a dump truck.

### Front Mounting Pad Position

**NOTICE!**

***DO NOT use tractive effort to move materials. It will cause damage to the grapple, position arm mounting pad, and/or excavator stick.***

Using the front position decreases the amount of grapple opening. This position works well when working at ground level because the lower jaw can be kept parallel to the ground. See figure #3

In this position, use the boom and stick in a raking motion to load the grapple. This mounting position can also be useful when placing objects, such as rip-rap.

**FIGURE #3**

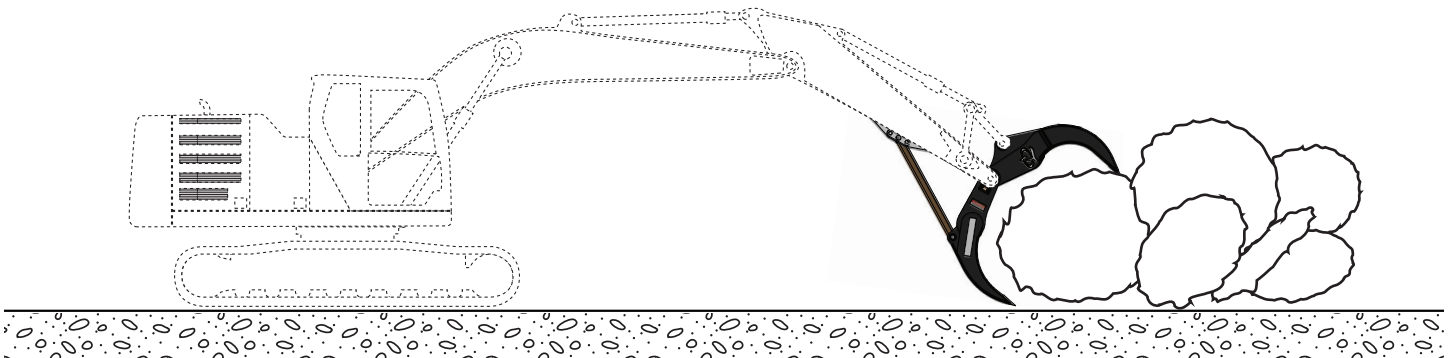

# Operation



## STORAGE

- ▶ Clean the unit thoroughly, removing all snow, mud, dirt, and grease.
- ▶ Inspect for visible signs of wear, breakage, or damage. Order any parts required and make the necessary repairs to avoid delays upon removal from storage.
- ▶ Tighten loose nuts, capscrews and hydraulic connections.
- ▶ Coat exposed portions of the main pivot & link pins with grease.
- ▶ Lubricate grease fittings.
- ▶ Replace decals that are damaged or in unreadable condition.
- ▶ Store unit in a dry, protected place off the ground. Leaving the unit outside and/or on the ground will materially shorten its life.

### Additional Precautions for Long Term Storage:

- ▶ Touch up all unpainted surfaces with paint to prevent rust.

## REMOVAL FROM STORAGE

- ▶ Wash unit and replace any damaged and/or missing parts.
- ▶ Lubricate grease fittings.

## LIFT POINTS

Lifting points are identified by lifting decals where required. Lifting at other points is unsafe and can damage attachment. Do not attach lifting accessories around cylinders or in any way that may damage hoses or hydraulic components See diagram.

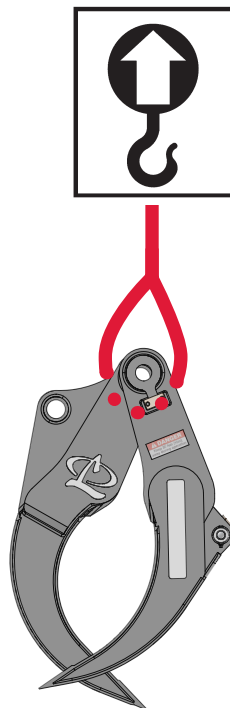

- ▶ Attach lifting accessories to unit at recommended lifting points.
- ▶ Bring lifting accessories together to a central lifting point.
- ▶ Lift gradually, maintaining the equilibrium of the unit.

## **WARNING!**

**Use lifting accessories (chains, slings, ropes, shackles and etc.) that are capable of supporting the size and weight of your attachment. Secure all lifting accessories in such a way to prevent unintended disengagement. Failure to do so could result in the attachment falling and causing serious personal injury or death.**

## **TIE DOWN POINTS**

Tie down points are identified by tie down decals where required. Securing to trailer at other points is unsafe and can damage attachment. Do not attach tie down accessories around cylinders or in any way that may damage hoses or hydraulic components.

- ▶ Attach tie down accessories to unit as recommended.
- ▶ Check unit stability before transporting.

## **WARNING!**

**Verify that all tie down accessories (chains, slings, ropes, shackles and etc.) are capable of maintaining attachment stability during transporting and are attached in such a way to prevent unintended disengagement or shifting of the unit. Failure to do so could result in serious personal injury or death.**

## **TRANSPORTING**

Follow all local government regulations that may apply along with recommended tie down points and any equipment safety precautions at the front of this handbook when transporting your attachment.

# Lubrication



## LUBRICATION

All parts provided with grease fittings should be lubricated as indicated. If any grease fittings are missing, replace them immediately. Clean all fittings thoroughly before using grease gun.

 Lubricate daily or every 8 hours of operation, whichever comes first, with SAE Multi-Purpose Lubricant or an equivalent SAE Multi-Purpose type grease.

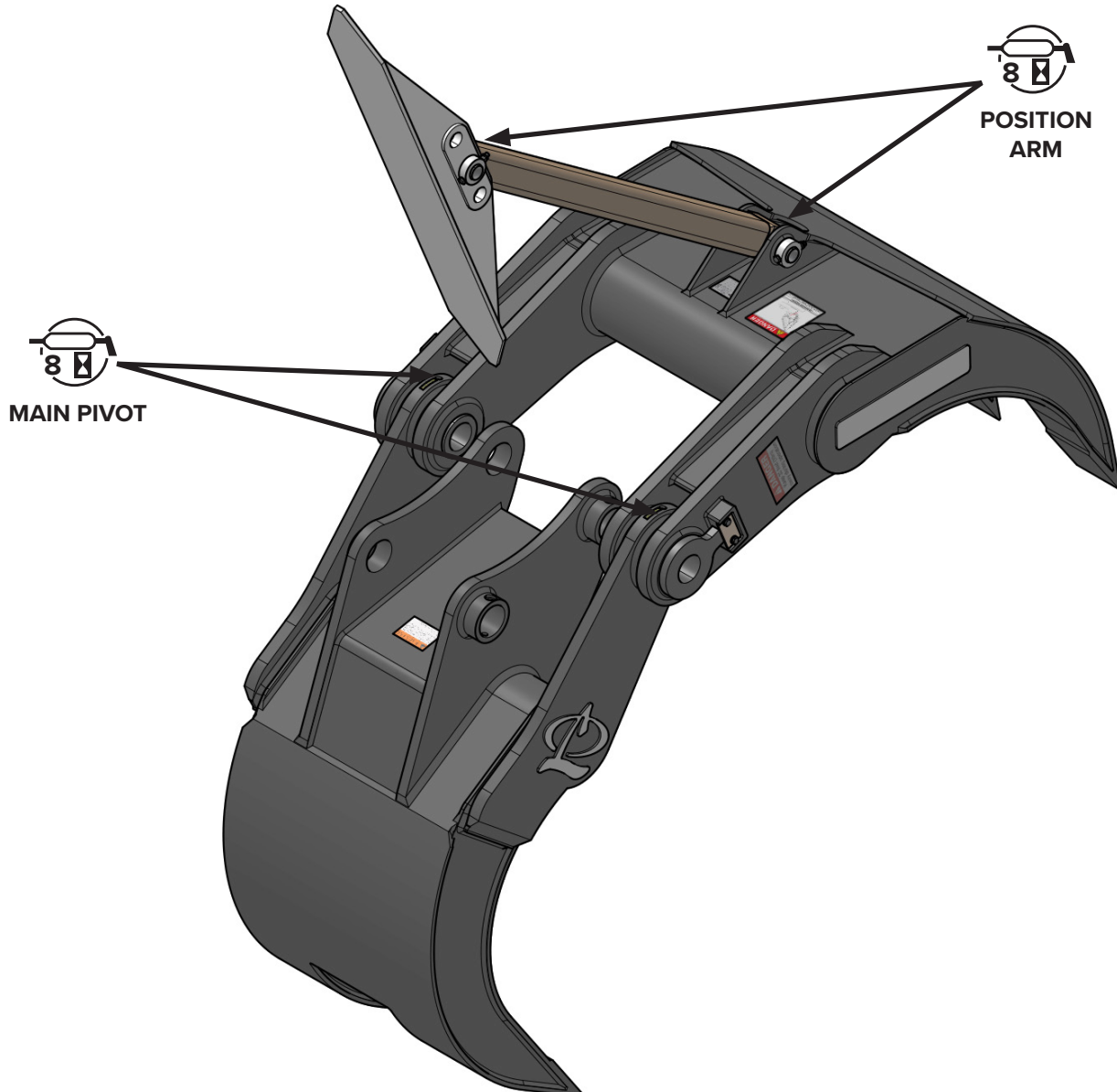

### NOTICE

*Apply a layer of grease to the pins (not shown) every 8 hours or operation.*

### IMPORTANT

**Avoid excessive greasing. Dirt collects on exposed grease and greatly increases wear. After greasing, wipe off excessive grease from fittings.**

# Maintenance



## GENERAL INFORMATION

Regular maintenance is the key to long equipment life and safe operation. Maintenance requirements have been reduced to an absolute minimum. However it is very important that these maintenance functions be performed as described below.

| PROCEDURE   | EVERY 8 HOURS<br>(DAILY) | EVERY 80 HOURS<br>(2 WEEKS) |
|---|--------------------------|-----------------------------|
| Check prime mover hydraulic system to ensure an adequate level and cleanliness of hydraulic oil.      | ✓                        |                             |
| Check for missing or loose hardware. Replace or tighten as necessary. See bolt torque specifications  | ✓                        |                             |
| Check hydraulic system for leaks and tighten as necessary. Check for damage and replace as needed.    | ✓                        |                             |
| Check for missing or damaged safety decals and replace as necessary.                                  | ✓                        |                             |
| Inspect attachment for any worn parts or cracked welds. Repair as required.                           | ✓                        |                             |
| Lubricate grease fittings.  | ✓                        |                             |
| Ensure cab protection is in good condition and that excavator audible and visual systems are working. | ✓                        |                             |
| Inspect the Stick, Linkage and Mounting Pad pins. Ensure they are secure and undamaged.               | ✓                        |                             |
| Inspect the tine tips for looseness or damage (see “Tine Tip Maintenance” on page 30).                | ✓                        |                             |
| Inspect attachment wear and hardsurface if necessary (see “Build Up & Hardsurfacing” on page 31).     |                          | ✓                           |



### WARNING!

#### USE CARE WITH HYDRAULIC FLUID PRESSURE

Hydraulic fluid under pressure can penetrate the skin and cause serious injury or death. Hydraulic leaks under pressure may not be visible. Before connecting or disconnecting hydraulic hoses, read your prime mover’s operator’s manual for detailed instructions on connecting and disconnecting hydraulic hoses or fittings.

- ▶ Keep unprotected body parts, such as face, eyes, and arms as far away as possible from a suspected leak. Flesh injected with hydraulic fluid may develop gangrene or other permanent disabilities.
- ▶ If injured by injected fluid, see a doctor at once. If your doctor is not familiar with this type of injury, ask him to research it immediately to determine proper treatment.
- ▶ Wear safety glasses, protective clothing, and use a piece of cardboard or wood when searching for hydraulic leaks. **DO NOT USE YOUR HANDS!**

# Maintenance



## TINE TIP MAINTENANCE

Inspect the tine tips for damage or wear. A tine tip will need to be replaced when it has one inch or less of tip left. Refer to Figure #1. Contact your dealer for a replacement tine tip kit.

### **CAUTION!**

Wear personal protection equipment (PPE) at all times. This includes eye protection, hard hat, steel toe shoes, leather gloves and hearing protection that conforms to standards ANSI Z87.1 (Eye and Face Protection), ANSI Z89.1 (Head Protection), ANSI Z41.1 (Foot Protection) and ANSI S12.6 (S3.19) (Hearing Protection).

### Check Tine Tip Wear

1. Locate flat, hard ground (e.g. concrete floor).
2. Curl the attachment under the boom. Set it down on a firm, level surface with the jaws open. Block the jaws if necessary.

### NOTE

Work only on the jaw closest to the ground. Work only on tine tips that are closest to the ground.

### **WARNING!**

Tine tips are very heavy. Do not remove a tip if it's not supported. The tine tip may fall and cause injury.

3. Measure the tine tips from the back edge of the tip profile to the worn tip, as shown in Figure #1.

FIGURE #1

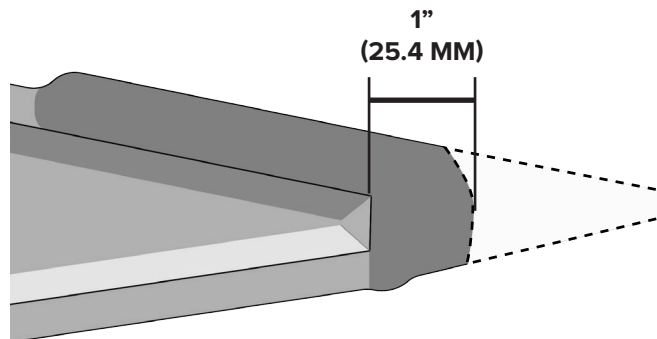

4. If the measurement is 1 inch (25.4 mm) or less, the tip must be replaced.

### Tine Tip Replacement

1. Thoroughly clean the tine tip to be replaced.



## CAUTION!

Wear personal protection equipment (PPE) at all times while welding. Allow only qualified, certified welders to maintain products.

- Using a straight edge, cut the worn edge of the tine tip at 0.75 inches from the back edge of the tip profile, as shown in Figure #2.

FIGURE #2

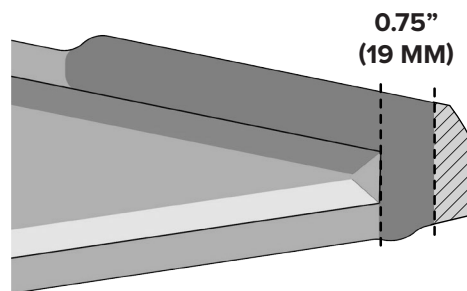

- Grind the cut area smooth and remove any carbon residue.
- Preheat the area to 200° F (94° C) to remove moisture.
- Heat the area to be built up to 300° - 400° F (149° - 205° C)

### NOTE

Do not exceed 450° F (233° C)

- Position the new tip and tack weld in place.
- Using a low hydrogen E7018 weld rod, weld the tine tip in place.
- Weld the bevels of the replacement tine tip and grind until smooth.

## BUILD UP & HARDSURFACING

### NOTICE!

*Do not use stainless hardsurface rod or other improper build up and hardsurfacing products. Using improper products may result in premature wear or cracking of the base metal.*



## CAUTION!

Wear personal protection equipment (PPE) at all times while welding. Allow only qualified, certified welders to maintain LaBounty products.

# Maintenance



## Build Up Recommendations

Choose a build up material that meets the following classifications.

Shielded Metal Arc Welding - Stick Electrodes

- ▶ E7018
- ▶ E8018-C3

Gas Metal Arc Welding - Solid Wire Electrodes

- ▶ ER70S-6

Gas Metal Arc Welding - Flux Cored Electrodes

- ▶ E71T-1
- ▶ E71T-1M
- ▶ E80T1-Ni1
- ▶ E80T1-Ni1M

Gas Metal Arc Welding - Metal Powder Cored Electrodes

- ▶ E70C-6M
- ▶ E80C-Ni1

## TINES & TIPS BUILD UP

Build up is required when excessive wear is found on the inner or outer face of the grapple tines, on the tips or on the sides of the frames near these areas.

1. Thoroughly clean the area to be built up.
2. Preheat the area to 200° F (94° C) to remove moisture.
3. Heat the area to be built up to 300° - 400° F (149° - 205° C)

### NOTE

**Do not exceed 450° F (233° C)**

4. Using a low hydrogen AWS E7018 welding rod, make single underlayment passes along the grain of the steel. Refer to Figure #3

## Hardsurfacing Recommendations

For hardsurfacing, LaBounty recommends;

- ▶ Amalloy 814H or equivalent

If you have questions about what hardsurface material to use, contact LaBounty Customer Service at 1-800-522-5059.

- ▶ Always use hardsurfacing weld material with a chromium content of less than 10% and a severe impact-resistance rating, to prevent cracking.
- ▶ Apply hardsurfacing directly on top of build up welds.
- ▶ Remove paint from the area before hardsurfacing.
- ▶ When grinding or sanding, wear an approved respirator.
- ▶ Remove solvent, paint strippers and other flammable material from the area before hardsurfacing.
- ▶ Have a fire extinguisher nearby.
- ▶ Do all work in a well ventilated area.



**FIGURE # 3**

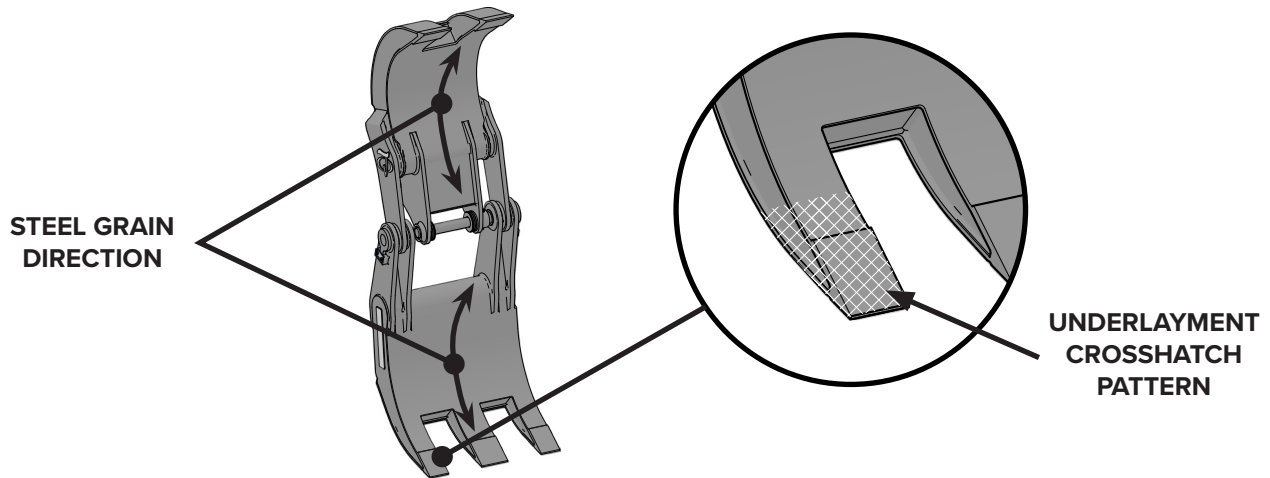

5. If welding on the tips, make underlayment passes in a crosshatch pattern, as shown in Figure #3.

**NOTE**

**Space the welds 1-2 inches apart.**

6. Relieve stress and remove slag after each pass by peening vigorously with an air operated slag peener.

**NOTE**

**Check the temperature often. Maintain 300° – 400° F (149° – 205° C).**

## **TINES & TIPS HARDSURFACING**

1. Apply a bead of Amalloy 814H rod directly on top of each underlayment bead.
2. Relieve stress and remove slag after each pass by peening vigorously with an air operated slag peener.
3. Taper the ends of each bead by grinding. Do not undercut the weld.
4. When grinding is complete, peen the area until it is shiny or until the peener cannot dent the weld, about 5-10 minutes.

**NOTE**

**Hardsurfacing should be applied in no more than two layers when using the crosshatch pattern.**

5. If the temperature has dropped below 400°F (205° C) within 6 inches of the welded area, heat the area up to 400° F (205° C).
6. Wrap the welded area with a heat blanket and allow to cool slowly.

# Tool Disposal



## Tool Body

Disassemble the tool and dispose of all non-metal parts. Recycle the metal components. Contact your local municipal recycling authorities for recycling instructions.



**THIS PAGE  
IS INTENTIONALLY  
BLANK**

# Specifications

## General Specifications

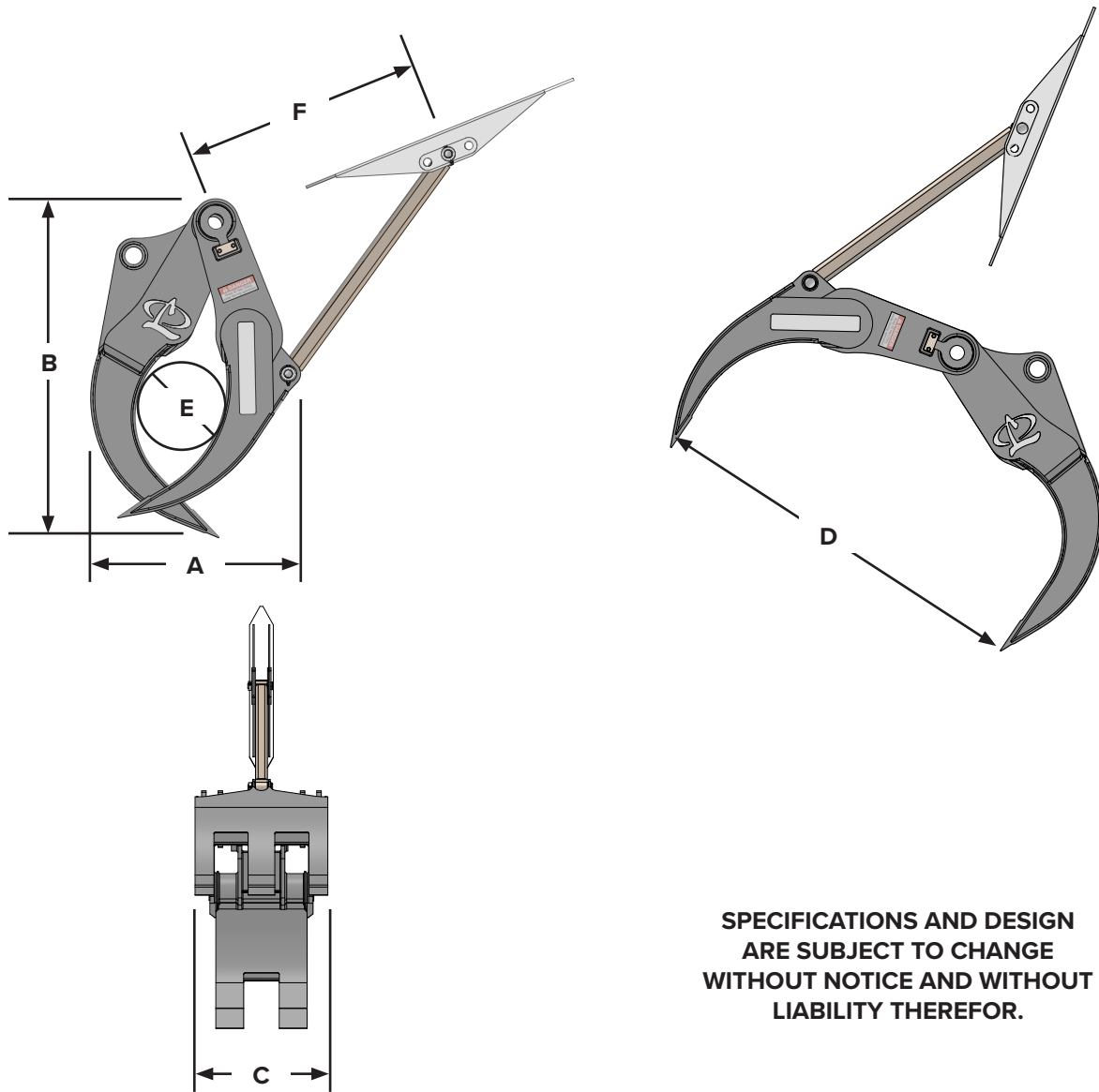

**SPECIFICATIONS AND DESIGN  
ARE SUBJECT TO CHANGE  
WITHOUT NOTICE AND WITHOUT  
LIABILITY THEREFOR.**

| <b>HDR UNIVERSAL GRAPPLE</b> |  |            |            |            |
|------------------------------|--|------------|------------|------------|
| <b>DESCRIPTION</b>           | <b>210</b>                             | <b>250</b> | <b>350</b> | <b>450</b> |
| A. Overall Length - Closed   | 39.00"                                 | 42.00"     | 45.00"     | 54.00"     |
| B. Grapple Height            | 70.00"                                 | 78.00"     | 87.00"     | 98.00"     |
| C. Overall Width             | 45.00"                                 | 45.00"     | 49.00"     | 53.00"     |
| D. Grapple Opening           | 108.00"                                | 114.00"    | 127.00"    | 140.00"    |
| E. Minimum Closed Diameter   | 11.50"                                 | 12.50"     | 12.50"     | 16.00"     |
| F. Mounting Pad Distance     | Varies by excavator model <sup>1</sup> |            |            |            |
| Weight (lbs)                 | 3500 #                                 | 4500 #     | 6200 #     | 7600 #     |

<sup>1</sup> Refer to the parts catalog or contact LaBounty Technical Service for machine specific mounting pad distance. Mounting pad distance is measured to the center hole on the mounting pad.

# Bolt Torque Specifications



## GENERAL TORQUE SPECIFICATION TABLES

Use the following charts when determining bolt torque specifications when special torques are not given. Always use grade 5 or better when replacing bolts.

### METRIC BOLT TORQUE SPECIFICATIONS

| Size of Bolt | Class No. | Pounds Feet   | Newton-Meters |
|--------------|-----------|---------------|---------------|
| M10          | 10.9      | 45 FT. LBS.   | 65 NM         |
|              | 12.9      | 50 FT. LBS.   | 70 NM         |
| M12          | 10.9      | 75 FT. LBS.   | 105 NM        |
|              | 12.9      | 85 FT. LBS.   | 115 NM        |
| M16          | 10.9      | 175 FT. LBS.  | 240 NM        |
|              | 12.9      | 210 FT. LBS.  | 285 NM        |
| M20          | 10.9      | 335 FT. LBS.  | 455 NM        |
|              | 12.9      | 405 FT. LBS.  | 550 NM        |
| M24          | 10.9      | 580 FT. LBS.  | 790 NM        |
|              | 12.9      | 695 FT. LBS.  | 945 NM        |
| M30          | 10.9      | 1165 FT. LBS. | 1580 NM       |
|              | 12.9      | 1395 FT. LBS. | 1895 NM       |



BOLT HEAD IDENTIFICATION MARKS AS PER GRADE.

#### NOTE

The following torque values are for use with metric hardware that is unplated and either dry or lubricated with engine oil. Reduce torque 15% when using hardware that has extreme pressure lubricants, plating or hard washer applications.

# Parts



In order to provide you with the most UP-TO-DATE part information, all parts for this attachment have been moved to our website at [www.paladinattachments.com](http://www.paladinattachments.com). Please use these diagrams and parts lists to locate replacement parts.

When servicing your attachment, remember to use only original manufacturer replacement parts. Substitute parts may not meet the standards required for safe, dependable operation.

To facilitate parts ordering when contacting the factory, please have the product control number (PCN or C/N) or model and serial number of your product ready to ensure that you receive the correct parts for your specific attachment.

The product control number, model and serial number for your attachment should be recorded in the space provided on the cover of this manual. This information may be obtained from the serial number identification plate located on your attachment.

## IMPORTANT

**Most daily and emergency parts orders (in stock) received by 10:30 A.M. (Eastern Standard Time) will be shipped UPS Ground the same day received. UPS Next Day orders must be received by 1:30 PM (Eastern Standard Time.)**

### SERVICE DEPARTMENT

(218) 834-2123

(800) 522-5059

### For Fax and E-mail Orders

[labounty@stanleyworks.com](mailto:labounty@stanleyworks.com)

(734) 996-9014

# Warranty



In order to provide you with the most UP-TO-DATE Warranty information, Warranty Statement and Warranty Procedures along with Warranty Registration and Claim Forms have been moved to our website.



**LABOUNTY®**

© LaBounty

Two Harbors, MN, 55616 USA