

# STANLEY®

## MBX15 MOUNTED HYDRAULIC BREAKER



**USER MANUAL**  
Safety, Operation and Maintenance





# TABLE OF CONTENTS

SAFETY SYMBOLS.....	4
SAFETY PRECAUTIONS .....	5
TOOL DECALS .....	7
PRE-OPERATION .....	8
OPERATION .....	10
PROPER USE & CARE OF TOOL BITS .....	15
TROUBLESHOOTING .....	19
CHARGING THE MAIN ACCUMULATOR .....	20
RECOMMENDED TORQUE VALUES .....	21
FLOW TEST PROCEDURES .....	22
WEAR LIMITS.....	23
ACCESSORIES .....	24
SPECIFICATIONS .....	24
MBX15 POWER CELL ILLUSTRATION.....	25
MBX15 POWER CELL PARTS LIST .....	26
MBX15 HOUSING PARTS .....	27

## IMPORTANT

To fill out a product warranty validation form, and for information on your warranty, visit [www.stanleyinfrastructure.com](http://www.stanleyinfrastructure.com) and select the Company tab > Warranty.

**Note:** The warranty validation record must be submitted to validate the warranty.

**SERVICING:** This manual contains safety, operation and routine maintenance instructions. STANLEY recommends that servicing of hydraulic tools, other than routine maintenance, must be performed by an authorized and certified dealer. Please read the following warning.

## ⚠ WARNING

**SERIOUS INJURY OR DEATH COULD RESULT FROM THE IMPROPER REPAIR OR SERVICE OF THIS TOOL.**

**REPAIRS AND / OR SERVICE TO THIS TOOL MUST ONLY BE DONE BY AN AUTHORIZED AND CERTIFIED DEALER.**

For the nearest certified dealer, call STANLEY at (800) 972-2647 and ask for a Customer Service Representative.



# SAFETY PRECAUTIONS

Tool operators and maintenance personnel must always comply with the safety precautions given in this manual and on the decals and tags attached to the tool and hose.

These safety precautions are given for your safety. Review them carefully before operating the tool and before performing general maintenance or repairs.

Supervising personnel or the owner operator should develop additional precautions relating to the specific work area and local safety regulations. Place the added precautions in the space provided in this manual.



## GENERAL SAFETY PRECAUTIONS

The Hydraulic Breaker will provide safe and dependable service if operated in accordance with the instructions given in this manual. Read and understand this manual and any decals and tags attached to the breaker before operation. Failure to do so could result in personal injury or equipment damage.

- Operate the breaker in accordance with all laws and regulations which affect you, your equipment, and the work site.
- Do not operate the breaker until you have read this manual and thoroughly understand all safety, operation and maintenance instructions.
- The operator must be familiar with all prohibited work areas such as excessive slopes and dangerous terrain conditions.
- Do not operate the breaker until you have read the carrier equipment manual and thoroughly understand all safety, operation and maintenance instructions. The word “carrier”, as used in this manual, means a backhoe or excavator or similar equipment used to operate the breaker.
- Ensure that all maintenance procedures recommended in this manual are completed before using the equipment.
- The operator must not operate the breaker or carrier if any people are within the area where they may be injured by flying debris or movement of the equipment.
- Know the limits of your equipment.
- Establish a training program for all operators to

ensure safe operation.

- Do not operate the tool unless thoroughly trained or under the supervision of an instructor.
- Become familiar with the carrier controls before operating the carrier and the breaker.
- When operating the breaker you must use ear protection, eye protection, and breathing protection.
- While learning to operate the breaker and carrier, do so at a slow pace. If necessary, set the carrier mode selector to the slow position.
- **Warning:** Use of this tool on certain materials during demolition could generate dust potentially containing a variety of hazardous substances such as asbestos, silica or lead. Inhalation of dust containing these or other hazardous substances could result in serious injury, cancer or death. Protect yourself and those around you. Research and understand the materials you are cutting. Follow correct safety procedures and comply with all applicable national, state or provisional health and safety regulations relating to them, including, if appropriate arranging for the safe disposal of the materials by a qualified person.
- Make sure all controls (levers and pedals) are in the NEUTRAL position before starting the carrier.
- While operating the breaker and carrier, keep hands and feet on the controls at all times.
- Before leaving the carrier, always lower the boom and insure the carrier is stable. Never leave the machine with the engine running. ALWAYS ENGAGE THE PARKING BRAKE.
- Stop the engine before attempting to make any repairs, adjustments or servicing to either the carrier or the breaker.
- Do not operate the tool at oil temperatures above 190°F/88°C. Operation at higher temperatures can damage the internal components of the breaker and carrier and will result in reduced breaker performance.
- Do not operate a damaged, leaking, improperly adjusted, or incompletely assembled breaker.
- Do not modify the breaker in any manner.
- Use only tool bits supplied by STANLEY. Use of tool bits supplied by another manufacturer may damage the breaker and will void the warranty.
- To avoid personal injury or equipment damage, all breaker repair, maintenance and service must only be performed by authorized and properly trained personnel.

# SAFETY PRECAUTIONS

- If you do not understand how to safely operate your breaker, contact an authorized STANLEY Dealer for assistance.
- Keep this manual with the breaker.
- Do not operate this equipment if you are taking medication which may affect your mental judgement or physical performance.
- Do not operate this equipment if you are under the influence of drugs or alcohol.
- Exposure to crystalline Silica (sometimes called “silica dust”) as a result of breaking, drilling, or hammering of rock, concrete, asphalt or other materials may cause Silicosis (a serious lung disease), silicosis-related illnesses, cancer, or death. Respiratory protection is highly recommended when working with materials containing Silica Dust. Always wear a respirator approved for protection against crystalline silica.

# TOOL DECALS

Shown below and on the next page are decals and stickers found on the equipment that provide important information. Replace decals and stickers when they are no longer legible. Decals may not be of actual size.



Part Number 47351  
Warning: Read Manual, Use Breathing, Hearing, Eye Protection Sticker



Part Number 72074  
Grease Sticker MBX15



Part Number 39704  
Accumulator Spec Sticker MBX15

## MBX15

Model Number Sticker  
P/N 73007 – MBX15

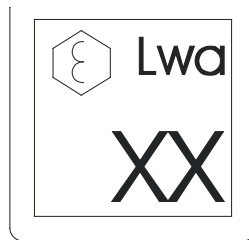

Sound Power Level Sticker  
P/N 66218 – 126 dBA MBX15

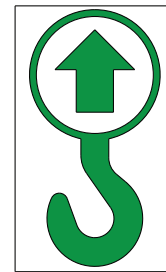

Lifting Point Decal  
P/N 47352



STANLEY Logo Sticker  
P/N 74705– MBX15

Note: Decals shown are not of actual size

# PRE-OPERATION

## PRE-INSTALLATION INSTRUCTIONS EXCAVATOR SIZE

Contact STANLEY to determine correct excavator size. See the "SPECIFICATIONS" section of this manual for hydraulic flow and pressure requirements.

### NOTICE

If hydraulic pressure, hydraulic back-pressure, hydraulic flow, or excavator weight class are exceeded, the tool warranty is void.

### EXISTING EQUIPMENT HYDRAULICS

Using existing equipment hydraulic auxiliary systems for operating hydraulic tools could cause problems for the hydraulic tool and the hydraulic system if not set up properly. Simply plugging into the hydraulic system without confirming pressure and flow to the hydraulic tool is not a good practice. Spare spool valves, dipper circuits, etc., are just a few examples of easily accessible hydraulic circuits which could prove to cause problems for hydraulic tool usage.

### TEST THE HYDRAULIC SYSTEM

1. Have your STANLEY dealer test the excavator hydraulic system to make sure the system is operating at the manufacturer's specified capacity and pressure ratings.
2. Be sure the fluid in the hydraulic system is clean.
3. Check the hydraulic filter. Replace the filter if dirty or deteriorated.
4. Have your STANLEY dealer test the circuit to which the breaker will be connected to make sure that the circuit is supplying the specified flow and pressure rating for the breaker. See the SPECIFICATIONS section of this manual.

## PREPARATION FOR OPERATION

### NITROGEN CHARGE

The breaker has been properly charged with nitrogen at the factory and is ready to use (see page 20) for charging information.

### TOOL BIT LUBRICATION

Grease the top 250 mm/10 inches of the breaker tool

bit before installing. During operation, the tool can be greased through the grease fitting. Grease as required. **Make sure the tool bit is against the tool stop by placing the tool bit against the ground and then putting down pressure on the breaker. SEE THE ILLUSTRATION BELOW AND ON THE FOLLOWING PAGE.**

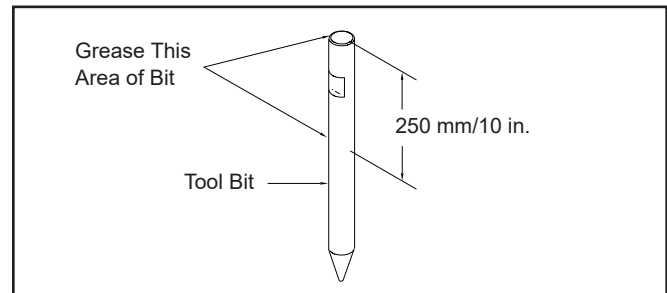

Figure 1. Greasing the Tool Bit Before Installation

### NOTICE

**Greasing the tool bit without down pressure on the tool will result in grease filling the space between the piston and the tool bit.**

**When the breaker is next activated, the piston will strike the grease at a speed that will cause the grease to apply great force against the seals and grease zerk resulting in damage to these components.**

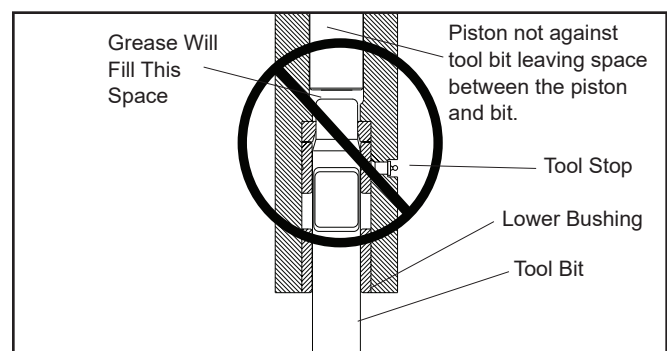

Figure 2.

### SECURING THE TOOL

5. Lay the breaker in a horizontal position to install the tool bit. Remove the rubber plug (item 35) and the retainer pin (item 28), see Figure 3 below.

Figure 3.



# PRE-OPERATION

## IMPORTANT

When installing the tool retainer pin (item 28) make sure the rubber plug (item 35) is fully seated. The rubber plug **MUST** be installed **BELOW FLUSH** to properly secure the pin.

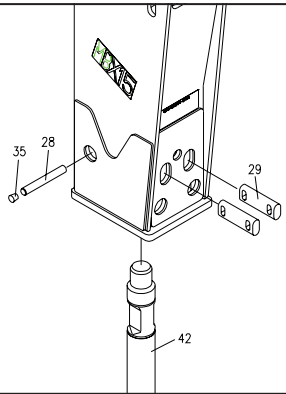

- Using a punch and hammer, drive out the tool retainer pins (item 29).

## WARNING

Flying debris may be caused by striking the rod pins with a punch or hammer.

Wear eye protection when installing or removing the rod pins.

Failure to wear eye protection may result in eye injury.

- Grease the top area of the tool bit as shown on the previous page.
- Install the tool bit making sure the notches are aligned with the lower body tool retainer pin holes.
- Install the tool retainer pins, retainer pin and rubber plug. See "Important" Figure 3.

## LOW-TEMPERATURE WARM-UP PROCEDURE

- After starting the excavator, warm-up the hydraulic system at engine idle until hydraulic lines are warm to the touch.
- With the excavator at idle and the breaker suspended in the air or with minimal down pressure, turn on the breaker to gradually warm up its internal components.
- When the hydraulic system and breaker are warm, proceed with operation. See the OPERATION section of this manual.

## LONG TERM STORAGE

Use the following procedure if storage of the breaker is expected to be more than 6 months.

**IMPORTANT:** The piston protrudes out the bottom of the cylinder when not in use, although it is inside the lower body it will still be exposed to the elements and will rust damaging internal components when it is put back into service.

Remove the tool bit and discharge the nitrogen gas from the upper accumulator. Use the tool bit to push the piston inside the cylinder where it will be protected from the elements. Grease the lower end of the exposed piston thoroughly. Also thoroughly coat the tool bit, tool stop, retaining pins, and lower bushing with grease.

If hoses are attached to the breaker, install plugs on the hose ends. If hoses are removed from the breaker, install plugs on the hose ends and install plugs in the breaker "IN" and "OUT" ports.

Store breaker in a dry area under cover if possible. It is best to store the breaker in an area that has a consistent temperature to help avoid water condensation causing rust. Store the breaker in a vertical position. Do not store the breaker horizontally for extended periods.

If the breaker has been laid horizontally for more than 6 months, check and/or replace all seals. Check for corrosion of bolts before operation.

## PREPARATION FOR USE

Read the section in this manual titled PREPARATION FOR USE before operating a breaker. Failure to follow the preparation instructions can result in severe damage to the breaker and excavator and void the warranties of both.

## POSITIONING THE EXCAVATOR

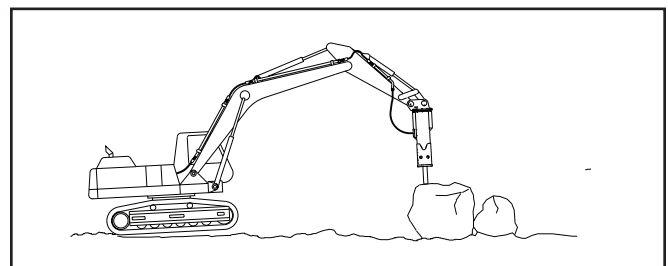

Figure 4. Position the Excavator

With the breaker tool in place on the material to be worked, position the excavator so the dipper is at approximately 45° and the breaker is almost vertical. The tracks of the excavator should be in line with booms and the breaker.

## POSITIONING THE BREAKER TOOL ON

# OPERATION

## THE WORK MATERIAL

Position the tool bit near the edge of the work material, not in the center or far from the edge. Position the tool 6-18 inches (depending on the material) from the edge. Breaking off smaller pieces of rock or concrete usually accomplishes more than trying to break larger pieces.

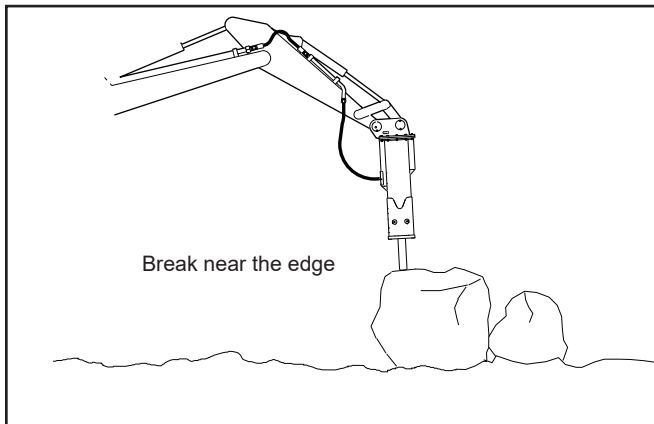

Figure 5. Position the Breaker

**On flat material or rock**, the breaker should be vertical or “curled” back slightly to direct the impact force downward and toward the backhoe. This directs the force back toward the edge of the work material. If the tool is positioned in the center of the work, or too far from the edge, the energy will be absorbed into the material without cracking it. Do not run the breaker longer than 15-20 seconds. If breakout does not occur within this time, move the breaker to another position.

On flat material such as concrete runways, starting to break in the middle of the material may cause vibrations to be transmitted throughout the breaker and excavator because the material has no place to break to. Always try to start at a point which will permit the material to break out.

## MAINTAIN DOWN PRESSURE

Maintaining hard contact with the surface of the material to be broken in addition to maintaining adequate “down force” is very important. Always keep “down pressure” or “down force” on the point of the breaker by lifting the wheels, tracks, or stabilizers slightly above the ground. This method takes the “slack” out of the bracket and boom pivots, and reduces the impact on the pivots in the boom.

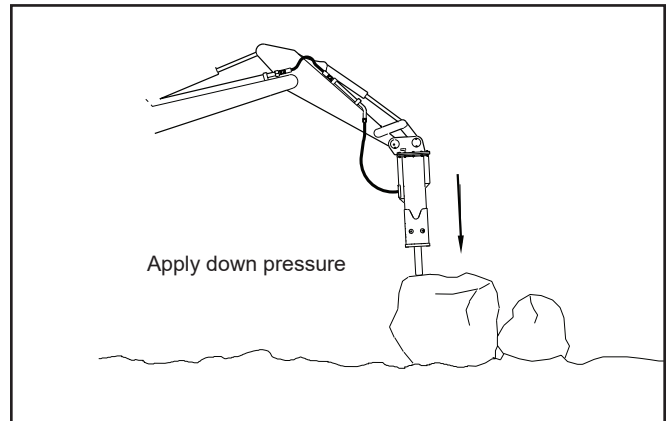

Figure 6. Maintain Down Pressure

The operator needs to be constantly aware of the amount of down pressure being applied and be able to adjust it if necessary. Not enough down pressure results in low production and accelerates wear and tear on the equipment. Too much down pressure may cause the breaker housing to violently crash into the broken material when “break-through” occurs.

In any breaking job, the operator should make every effort to “**follow**” the breaker with “down-pressure” as the machine breaks farther into the material. The breaker should be stopped as soon as “break-thru” occurs or if it is apparent that good solid blows are not occurring.

## BREAKING

The operator should note the sound of the blow when the breaker is running. With experience, the operator will be able to tell the difference between a good solid blow and a hollow sounding blow. A hollow blow means that solid blows are not occurring and the breaker should be repositioned.

Continuous tool penetration usually does not do much good. If the material does not break with 3 to 4 inches of tool penetration, it usually won’t break with full penetration. The time used for additional penetration could be better used to strike blows in another place.

# OPERATION

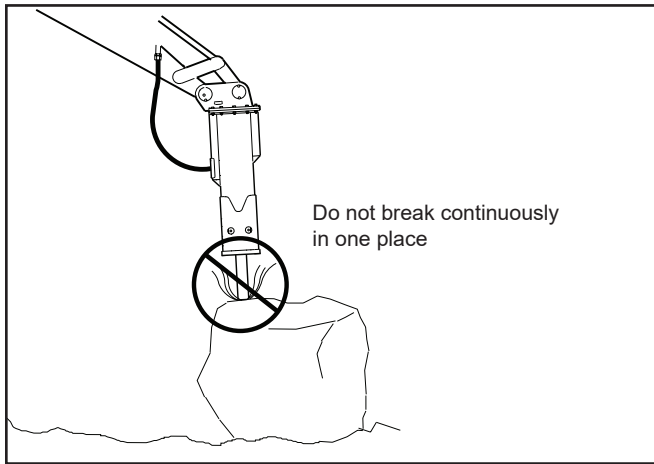

Figure 7. Breaking

## NOTICE

Continuous breaking in the same area for lengthy periods will create excessive temperatures at the tip of the tool bit resulting in loss of temper (hardness) of the bit and causing mushrooming of the tip of the bit, and may lead to failure of the bit.

Many materials do not respond well to continued hammering in one place. The breaker tool should be repositioned on the work each time the tool penetrates but does not crack the material.

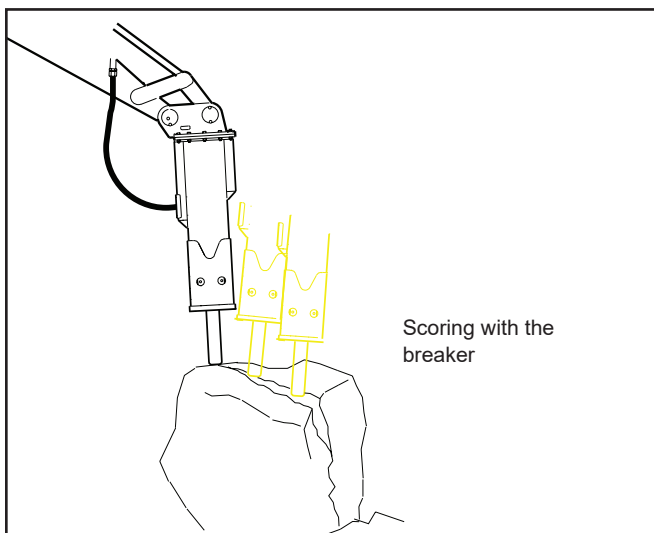

Figure 8. Scoring with Breaker

Use a “scoring” method of breaking when cracking the material becomes difficult. This technique involves strik-

ing the rock or concrete at several places along a line where you want the crack to occur. Most materials break sooner when struck several places along a line than when struck repeatedly in one location. On each line, the breaker tool should be continually repositioned. Practice determines the best length of time to stay in one spot (15-20 seconds) and how far to move the breaker tool.

Breaker tool binding can cause erratic breaker operation and premature wear on the tool shank. Breaker tool binding is caused by failure to direct the down force in the direction of the tool bit.

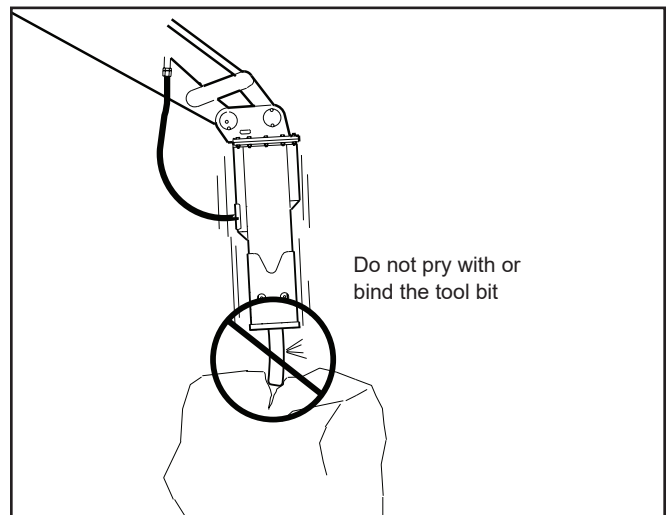

Figure 9. Breaker Binding

Excessive side force cocks the tool in its bore, prevents proper movement and causes premature tool shank and bushing wear. Since the breaker tool bit must be pushed up into the breaker to operate, a binding tool prevents the breaker from operating correctly. Binding also causes the tool bit and tool bushings to seize and often results in breakage of one or more breaker components. Always direct the down pressure force in a line toward the point of tool contact with the work.

## NOTICE

DO NOT pry with the tool bit and breaker. Prying will damage the tool bit and associated breaker components.

Moving rocks with the tool bit is another method of binding the tool bit. This practice should be avoided as it may cause tool bit failure.

# OPERATION

Rebar reinforced concrete introduces the problem of concrete chunks being held together by the rebar after the concrete has been broken. The best approach to this problem is to use a chisel point tool which permits cutting the rebar with the breaker. Another method is to periodically cut the rebar with an oxyacetylene torch.

## BLANK FIRING

To understand “Blank Firing”, the operator needs to be aware that if the tool bit is not pressed against the work surface the tool bit will drop down in the lower body cavity far enough so that the piston cannot strike it. Blank firing occurs whenever the breaker is operating and the piston is not able to strike the tool bit solidly or not strike the tool bit at all. Blank Firing accelerates wear and tear on breaker and excavator components and may result in failure of one or more components. Excessive blank firing may be considered equipment abuse and may result in voiding warranties.

Break-through or difficult surface contact results in blank firing when the material being broken fractures and the tool bit is no longer in “hard contact” with the material but is still pushed high enough in the lower body cavity so that the piston can strike it. In this condition, the piston strikes the tool bit and the tool bit, in turn, is driven against the retaining pins because it is not in sufficient contact with the material to be broken. The energy is absorbed by the retaining pins, other breaker components, and the excavator boom components. Blank firing of this type can be experienced in trench work where obtaining striking contact with the work surface is difficult or the wrong tool bit is used, or in flat rock work where the operator fails to stop operation of the breaker when slippage, fracturing or material break-through occurs.

Blank firing as a result of operator error occurs when the tool bit is not in contact with the work surface to be broken and is allowed to drop down in the lower body cavity so that the piston is not able to strike it. Instead, the downward movement of the piston will be stopped by an internal oil cushion located at the bottom of the piston's stroke and the energy of the piston will be absorbed by breaker components and excavator boom components. Blank firing of this type can be experienced when the operator fails to stop operation of the breaker when the material fractures or material break-through occurs, or during re-positioning of the breaker.

While blank firing cannot always be avoided, it can be kept to a minimum by avoiding the above conditions as much as possible.

# OPERATION

## UNDERWATER USE

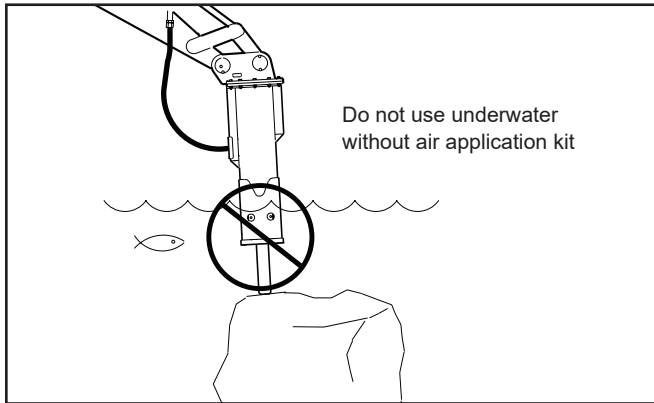

Figure 11. Underwater Use

## CAUTION

### UNDERWATER USE

No part of the breaker may be submerged in water unless an air application kit is used. Underwater usage of the breaker without air application will cause internal damage to the breaker. Consult STANLEY for modifications and specific warranty coverage if you have an underwater requirement.

The breaker is equipped with an underwater port on the side of the breaker. Connect an air line to this port and supply the required air pressure and flow to the breaker when using underwater. The following table shows the air pressure required.

Model	Required Air Amount	Required Air Pressure	Compressor Horsepower-Min	Fitting Location on Exploded View
MBX15	0.5m <sup>3</sup> / min	75-100 psi /5-7 bar	3.7 Kw	Item # 9A

# OPERATION

## EACH DAY

- Check for loose or missing fasteners. Tighten or replace as needed.
- Inspect tool retaining pins and pockets for wear.
- Check for hydraulic leaks at all fittings and hoses. Replace any defective hoses.
- Apply grease to the grease fitting in the lower body each morning. Grease as needed throughout the work day.
- Inspect the lower bushing, tool retainer, tool retainer pins. Reseat or replace if necessary.

## TOOL STOP & LOWER BUSHING

Inspect the tool stop, and lower bushing for excessive galling and metal pickup on the tool bit. Also check for cracks. If cracks are present, the parts must be replaced.

The extent of wear of the tool stop and lower bushing and the tool bit can be checked by moving the tool bit back and forth and measuring the gap between the tool bit and the lower bushing. If the gap is more than 0.354 in./9 mm the tool stop, lower bushing, and the tool bit should be replaced. A gap in excess of 0.354 in./9 mm will cause damage to the piston. Do not just replace the tool bit or the lower bushing individually as this will result in premature wear of the replaced component. It is recommended to replace **all** worn components.

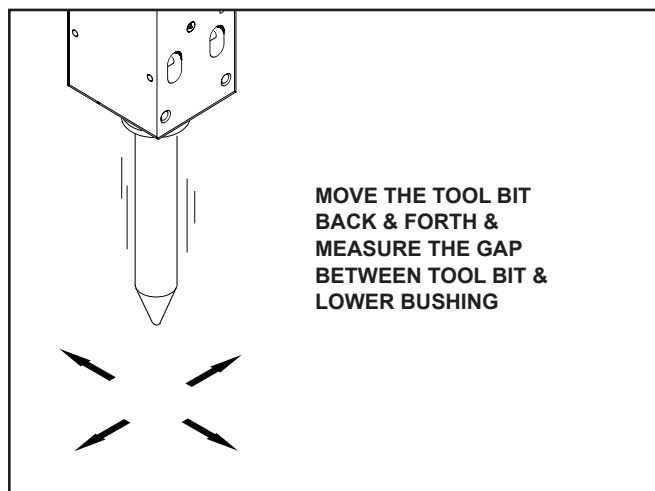
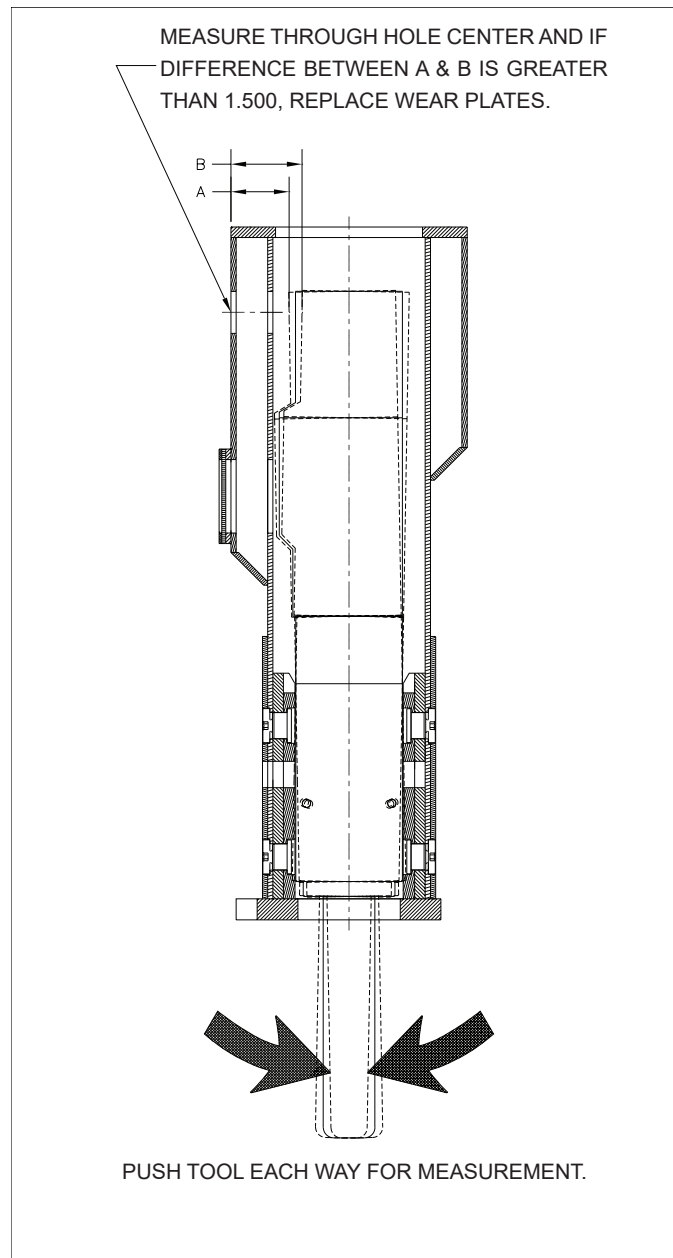

Figure 12. Checking for Wear

## PERIODIC MAINTENANCE CHECKS

- Periodically check wear pad clearance by moving the power cell back and forth. Set the breaker on the bit and then use the excavator to move it from side to side as shown in the illustration. If the deflection exceeds 1.5 inches, replace the wear pads.



Tool bits are made and heat treated to specification.

Tool bits, however well made, are wear parts, and are used in the most destructive applications. Even when the hydraulic breaker is used properly, and the operator is an experienced one, a tool bit may become damaged. When a tool bit has been damaged, it is useful to determine the cause immediately in order to prevent the damage from occurring again.

All STANLEY tool bits are machined and hardened for maximum performance. Care must be taken to maintain the tools original condition for optimum productivity and life expectancy. It is not uncommon for an operator who

# PROPER USE & CARE OF TOOL BITS

is unfamiliar with using a hammer to break a point. This is part of the learning experience.

Listed below are several methods to determine tool failure and will quickly aid in warranty determination.

## TOOL FAILURE NOT COVERED UNDER WARRANTY

### BLANK FIRING OR FREE RUNNING

This occurs when the tool is not in proper contact with the work, thus causing the energy produced by the hammer to be concentrated on the tool retainer(s) and the retainer slot(s) on the tool itself. Caution should be used to prevent the hammer from sliding off slanted surfaces or when breaking through thin material.

The illustration below is typical of the kind of breakage that occurs from excessive blank firing.

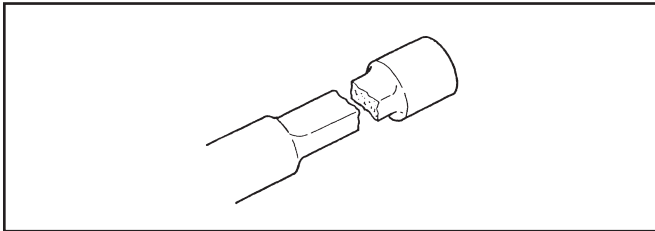

Figure 13. Excessive Blank Firing Breakage

### WORN-OUT FRONT BUSHING(S) OR RETAINER PIN(S)

Worn-out front bushing(s) will cause the tool to become misaligned inside the hammer. This misalignment will cause uneven contact between the piston and tool, thus causing stress to concentrate on one particular area of the tool. This can also cause the tool to bind inside the hammer. Call your dealer for acceptable wear allowances.

Worn-out retainer pin(s) will cause uneven loading on the pin(s) themselves, causing failure of the tool or retainer pin(s). This will also cause excessive wear to the front bushing(s).

### METAL-TO-METAL CONTACT

Extreme caution should be used to avoid scratches or gouges on the surface of the tool. These areas create a stress concentration Metal-to-Metal Contact point, thus weakening the tool.

Another form of metal-to-metal contact is galling, which usually occurs from the lack of lubrication. Special care

should be taken to keep the tool shank lubricated every two (2) to three (3) hours.

Steel failures that were caused by surface damage take two main forms. The simplest form is caused by deep scratches on working steel surface. The broken surface has a shell pattern around the starting point of failure, similar to the one in the fatigue failure. The other parts of the broken surface are brittle. These failures work slowly through the steel until it suddenly parts completely.

The second form of failure caused by surface damage occurs when there are deep scratches on working steel surface and there was also excessive bending stress. The broken surface also shows the shell pattern, but the other parts of the broken surface are brittle and usually have a “lip” like that in a stress failure.

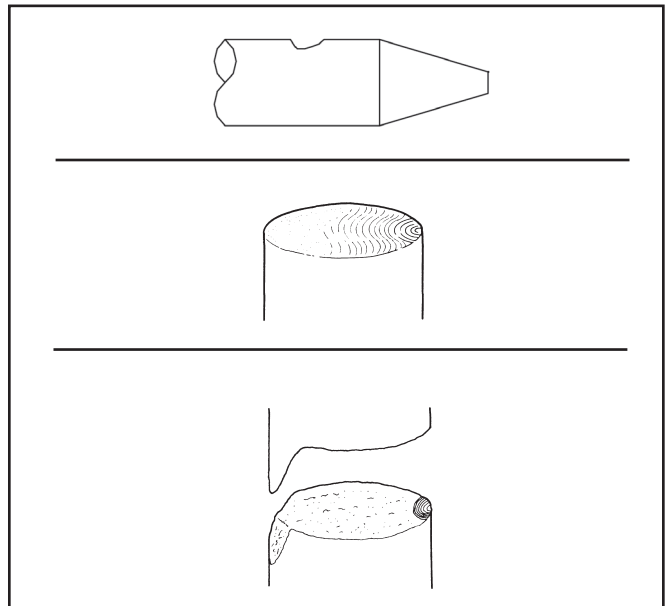

Figure 14. Metal-to-Metal Contact Examples

In its most extreme forms, the combination of surface damage and severe bending can quickly break even the best working steels.

The illustrations below show examples of severe stress breaks.



# PROPER USE & CARE OF TOOL BITS

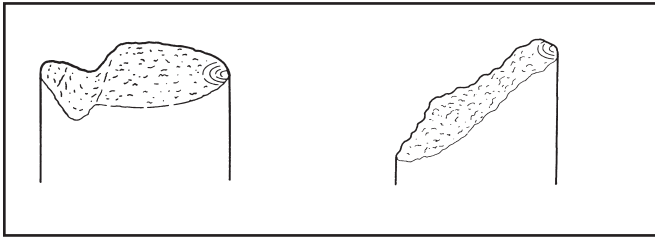

Figure 15. Severe Stress Breaks

## PRYING

This is the most common cause of tool failure. Even when there is no surface damage, the stress from prying can easily break a working steel. This kind of failure generally results from any type of side pressure such as an incorrect breaking angle or from using the tool to reposition material. The tool should not be used as a pivot point when repositioning the carrier. The power generated by the carrier will far exceed the strength of the tool.

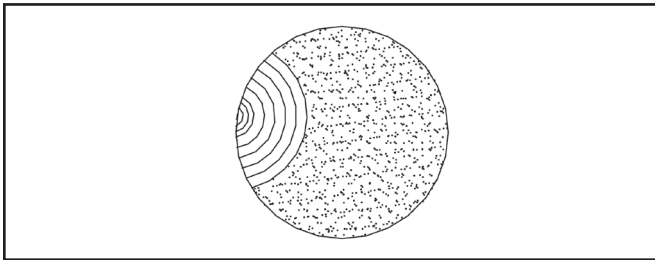

Figure 16. Prying Damage Example

Similar failures can also occur when the steel is used with extreme down pressure, and the steel repeatedly slips off the work at an angle, or the material, itself moves from under the working steel.

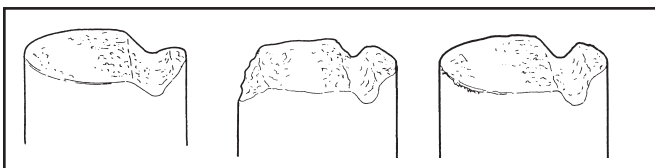

Figure 17. Extreme Down Pressure Breakage

As the next illustration shows, fatigue failures take many forms, but they all exhibit similar features. Generally, the broken surface is brittle and has a “lip” like that in the bending failure, even though, in some cases, the lip has been broken.

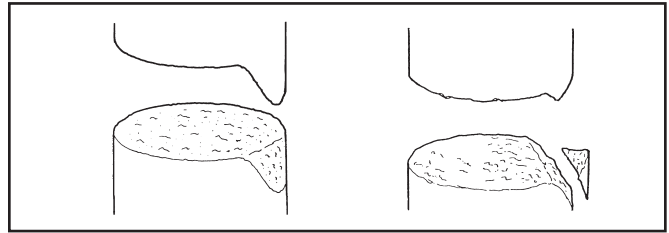

Figure 18. Fatigue Failures

## CORROSION

Tools should be greased and stored out of the weather. Corrosion tends to accelerate the fatigue fractures of the tool.

## MUSHROOMING

Driving the tool into a hard material for a long period of time generates an intense heat, indicated by a blue tone just above the point. This will soften the steel and cause the point to fold over or mushroom the end of the tool. Avoid hammering in one location for too long. If material does not break after a short period (approximately 15 to 20 seconds), reposition the tool.

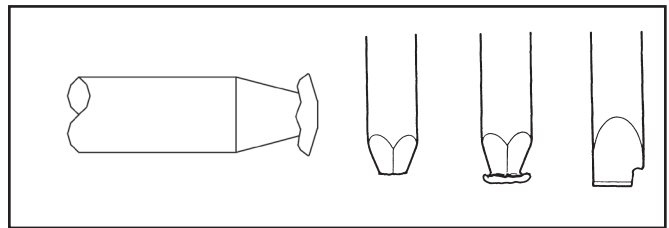

Figure 19. Mushrooming

If the overheated steel is suddenly cooled by being dipped in standing water, for example, the metal will harden and become brittle. These are some examples of failure caused by temper changes occurring on the job.

## TOOL FAILURE COVERED UNDER WARRANTY

### INTERNAL MATERIAL FLAW

This failure occurs when a foreign material is rolled into the steel during the manufacturing process, causing an imperfection in the internal material flaw grain. The result is an inherent weakness in the tool shank and eventual breakage.



# PROPER USE & CARE OF TOOL BITS

The fatigue failure is started by the defects within the tool bit. The broken surface exhibits a shell pattern around the starting point of failure, like that in the fatigue failure. The other parts of the broken surface are brittle.

**This is the only kind of tool bit failure that is always covered under warranty.**

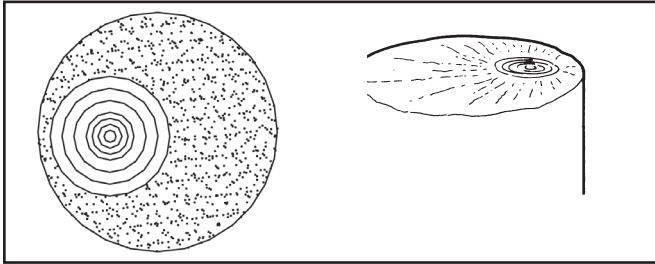

Figure 20. Internal Material Flaw

As a rule, working steel failures can be diagnosed by looking at the break itself, and at the place on the steel where the break occurred. Discoloration, like “rainbow” effects or blue bands, is the result of extreme heat.

Look for surface cracks, galling, or gouge marks. Breaks that start as surface damage have a “sea shell” pattern, with the damaged spot at the center. A large “sea shell” indicates a slow growing break; a small one indicates one compounded by side stress.

Stress failures start small, and spread into the center of the steel. In a stress failure, the coarser the grain, the greater the stress was, and the more rapid was the failure.

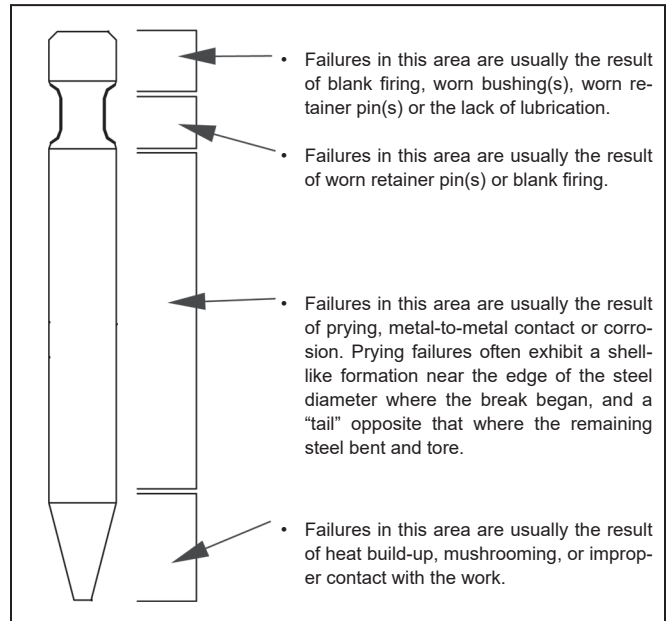
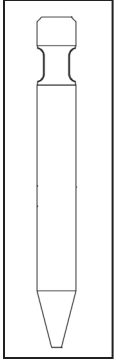

Figure 21. Diagram of Tool Bit Failures

# PROPER USE & CARE OF TOOL BITS

STANLEY breakers are available with several different types of tool bits. The most common are themoil, chisel and the blunt. Each of these working steels has its own purpose as described below:

To obtain the maximum production from the breaker, it is important to select the proper working steel. Consult your STANLEY representative for assistance in selecting the proper working steel for your application.



## MOIL

This is by far the most popular working steel. It is a general purpose point used to break anything from concrete to hard rock. Its pencil-type point is used to fracture the material. The tool is best where penetration speed is important.

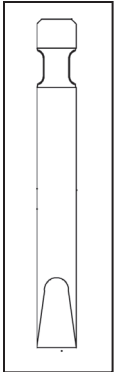

## CHISEL

This style of point is used generally used for trench work, where a controlled break is required, and for rock breaking on materials with a definite line of cleavage. A chisel bit also works well in softer concretes where amoil might penetrate quickly, but not cause a fracture line.

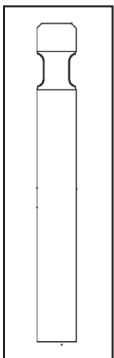

## BLUNT

This flat type of point is used to break softer material such as coal or shale. Amoil or chisel will tend to punch holes in this type of material, where a flat blunt will shatter the material. It is also useful when breaking irregularly shaped material where its broad tip makes it easier to position.

# TROUBLESHOOTING

If symptoms of poor performance develop, the following chart can be used as a guide to correct the problem.

When diagnosing faults in operation of the breaker, always check that the hydraulic power source is supplying the correct hydraulic flow and pressure to the breaker as listed in the table. Use a flow meter known to be accurate. Check the flow with the hydraulic oil temperature at least 180 °F/82 °C. An approved test procedure is available in the complete service manual, P/N 41893.

PROBLEM	CAUSE	SOLUTION
Breaker will not fire.	Low hydraulic oil level.	Fill reservoir.
	No flow to breaker.	Have hydraulic circuit tested by authorized dealer/distributor per approved procedure.
	Main relief set too low.	
	Internal damage.	Have unit serviced by authorized dealer/distributor.
Breaker runs slowly.	Low hydraulic flow.	Have hydraulic circuit tested by authorized dealer/distributor per approved procedure.
	Excessive heat build up.	
	Excessive nitrogen pressure.	Have unit serviced by authorized dealer/distributor.
	Internal leakage.	
Breaker runs erratically.	Low or excessive back pressure.	Have carrier serviced by authorized dealer/distributor.
	Damaged switch or connection.	
	Main relief set too low.	
	Internal damage.	Have unit serviced by authorized dealer/distributor.
	Tool binding.	
	Low hydraulic oil level.	
Breaker runs but at reduced power.	Low accumulator charge.	Have unit serviced by authorized dealer/distributor.
	Excessive back pressure.	
	Main relief set too low.	
Breaker leaks oil around tool bit and tool bushing.	Lower seals failed.	Have unit serviced by authorized dealer/distributor.
Hydraulic system overheats.	Main relief set too low.	Have carrier serviced by authorized dealer/distributor.
	Insufficient cooling capability in hydraulic circuit.	
	Line/hose size too small.	
	Excessive back pressure.	

# CHARGING THE MAIN ACCUMULATOR

The tools required to charge the breaker are shown below. The 33464 adapter and 33300 adapter assembly can be obtained individually or in a kit (P/N 33465). Note that the adapter and adapter assembly are designed to be used with the 505232 charge hose assembly and the 28257 accumulator tester which are used with other STANLEY breakers. When charging the breaker, make sure the tools and charge valve are clean. Dirt can contaminate the charge valve and cause leakage.

1. Remove the protective plug from the accumulator charge valve.
2. Screw the adapter assembly (P/N 33300) onto the tester (P/N 28257) and tighten it.
3. Hold the chuck end of the tester and turn the gauge fully counter clockwise to ensure the plunger inside the chuck is completely retracted.
4. Screw the tester into the breaker charge valve by turning the chuck. Do not use the gauge for turning as this will advance the plunger in the chuck. Tighten the chuck lightly against the breaker charge valve.
5. Turn the gauge clockwise to advance the plunger until a pressure is indicated on the gauge. Do not overtighten.

6. If the pressure is correct, unscrew the gauge to retract the plunger. Then, loosen and remove the tester from the charge valve. If the pressure is not correct, proceed to Step 7.

## NOTE:

**When disengaging the tester a "POP" of nitrogen is normal.**

7. Connect the charge hose assembly to the charging valve on the tester. Make sure the valve on the charge hose assembly is closed. Open the valve on the nitrogen bottle.
8. Very slowly open the valve on the charge hose assembly and slowly meter the nitrogen into the breaker charge valve until the tester reads the correct charge pressure.
9. When the correct pressure is obtained, close the valve on the charge hose assembly and on the nitrogen bottle. Unscrew the gauge to retract the plunger. Loosen and remove the tester from the charge valve. Before replacing the protective plug, inspect the plug O-ring. If damaged or deformed, replace the plug. Apply Loctite™ 242 to plug and cap.

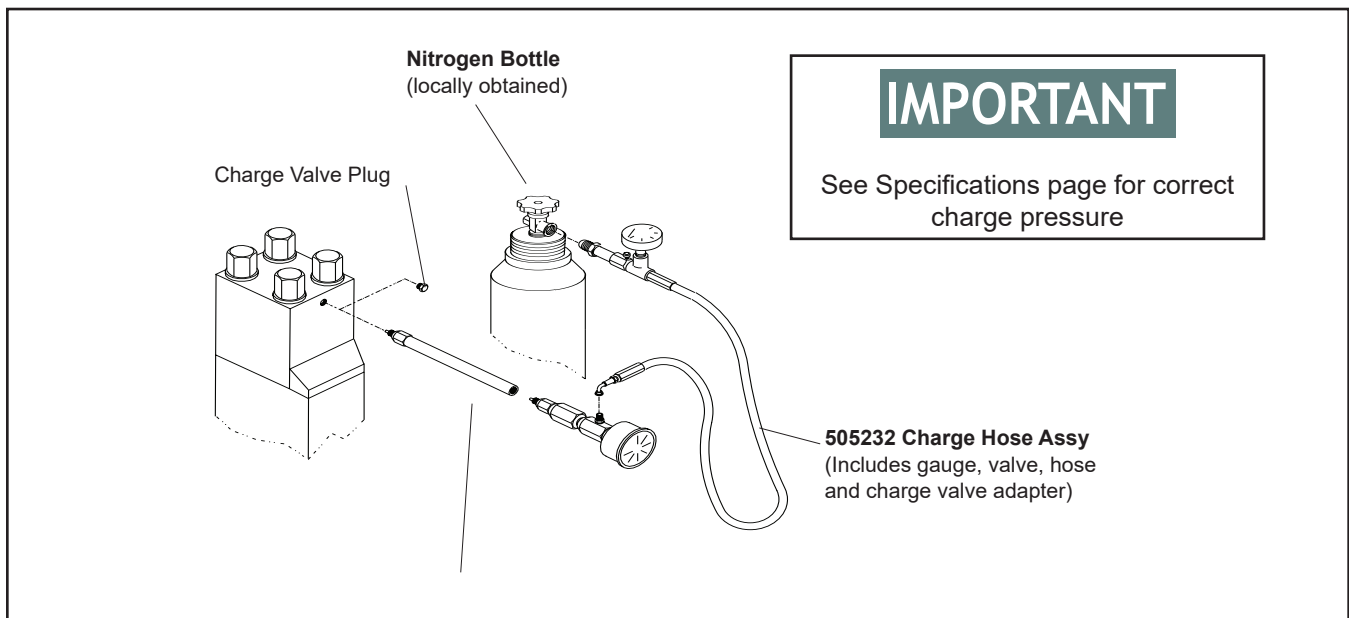
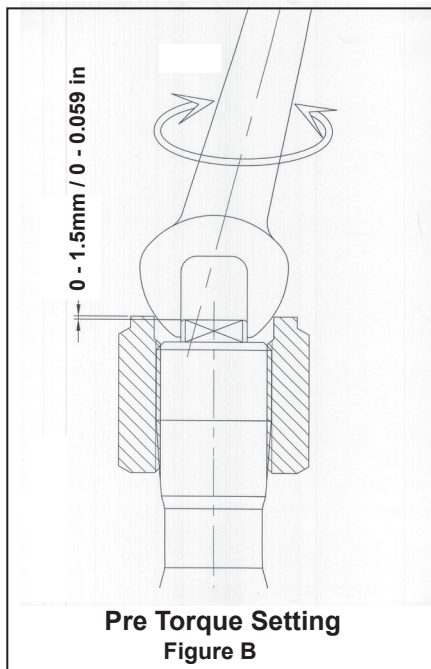

Figure 22. Charging the Main Accumulator

# RECOMMENDED TORQUE VALUES



MBX15 TORQUE TABLE					
ITEM NO.	ILLUSTRATION	DESCRIPTION	APPLY	FT/ LBS	NM
3	POWER CELL	CHARGE VALVE	LOCTITE™ 242	75	101
8	POWER CELL	O-RING PLUG	LOCTITE™ 242	130	176
2	HOUSING	CAPSCREW	—	455	617
5	HOUSING	MTG BRKTNUT	—	455	617
41	POWER CELL	TIE RODNUT <sup>1</sup>	KOPR KOTE™	720	976
9	POWER CELL	PLUG <sup>4</sup>	LOCTITE™ 680	30	41
4	POWER CELL	PLUG	—	20	27

The torque values for TIE RODS NUTS in the above chart are intended to be used with a torque multiplier.

The following procedure is the recommended procedure for tie rod torque and may be tightened to the specified torque using the following procedure (see figure A & B ).

1. Thread tie rod into lower nut by hand until it bottoms out. Then install the upper tie rod nut and install all the way down until contacts the top of the main accumulator, then hold the upper nut from turning and with a wrench turn just the tie rod until it has a gap as shown in figure B above (0 - 1.5mm / 0 - 0.059 in., top of tie rod flush or just below top of upper tie rod nut).
2. Pre-torque the upper tie rod nuts to 360 ft. lb. / 488 Nm using a cross pattern as shown in the illustration at the left.
3. Using the illustration as a guide, mark a line on each nut and designate it as (A).
4. Using the illustration as a guide, measure the degrees indicated in the chart, from point (A) to point (B) and make a mark near the nut. The degrees listed in (figure A) for turning the nut to achieve the final torque is listed as 120°-130°. Make a mark on one point of the nut and designate that point as (A). Measure 120°-130° degrees clockwise from point (A) and make a mark next to the nut. Designate that point as (B). Turn the nut clockwise until point (A) and point (B) line up.
5. Continue this procedure in a cross pattern on all 4 nuts.

## Recommended Tie Rod Torque Procedure

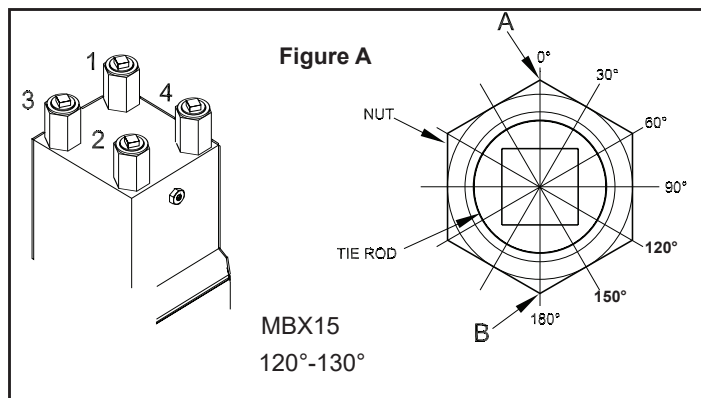

Tighten in a cross pattern  
Pre-torque to 360 ft. lb./488 Nm

# FLOW TEST PROCEDURES

The correct performance of this procedure will verify if the auxiliary circuit of the carrier is adequate to properly operate a STANLEY attachment.

This procedure is generic in form. It is the end users responsibility to ensure that this procedure will work with his specific type of equipment.

If an adequate flow meter is not available contact your STANLEY Distributor for assistance.

## TEST PROCEDURE

1. With the auxiliary circuit (or kit) completely installed connect the flow meter between the tool inlet and outlet hoses.

### NOTE:

**Always use the hoses that are supplied for the attachment and make sure the machine hydraulic oil is between 90 to 120 °F. This will assure correct readings and adjustments.**

2. With the machine setting at the mode that's going to be used to operate the attachment record the GPM \_\_\_\_\_.

Locate the correct flow for the attachment in the manual under the specification section. Adjust the machine to the correct GPM.

### NOTE:

**If possible, always set the machine to the highest GPM output mode. This will prevent the operator from over flowing the attachments.**

3. Once the correct GPM flow is achieved fully open the restrictor on the flow meter.
4. With the machine in the attachment mode set in step 2 record the back-pressure. At this point the pressure reading on the pressure gauge is the back-pressure in the circuit. This pressure must not exceed 200 psi/13.5 bar.

Excessive back-pressure will slow the attachments operation and lead to premature seal failures and over heating.

**Record the back-pressure \_\_\_\_\_ psi.**

5. Close the restrictor valve on the flow meter until the attachment relief starts to crack or open. The relief valve opens when the flow rate (GPM), indicated on the flow meter begins to decline rapidly. Locate the tools operating system relief pressure in the specification section in the manual. Adjust attachment relief to specification.

### NOTE:

**The relief valve pressure must be greater than the operating pressure of the attachment and three times the back-pressure. Never use the relief valve to control the flow rate in the circuit. Cracking pressure means the loss of 4 or more GPM.**

**Record the relief cracking pressure \_\_\_\_\_ psi.**

### Example:

Operation pressure of a breaker is 2700 psi. Back-pressure is 150 psi. A good rule to follow when setting the relief, multiply the back pressure by 3 then add this number to the operation pressure of the attachment.

Operating Pressure	2700 psi
Back-pressure	450 psi
Operating pressure of the tool	3150 psi

The relief valve setting must be greater than the estimated operating pressure of the tool. If the setting is lower, damage to the circuit may occur. Excess heat will be generated in the circuit which will damage the attachment and carrier.

## HEAT LOAD TEST

With the installation kit properly installed and adjusted per the above procedure, conduct the heat load test as follows.

1. Connect the flow meter between the tool inlet and outlet hoses.
2. With the carrier set in the attachment mode, restrict the flow meter until a pressure of 1000 psi is achieved. This pressure must be maintained throughout the heat test.

### NOTE:

**Closing of the restrictor may be required as the temperature increases.**

Monitor the oil temperature from the flow meter until no change is noted. Record the time required for oil to stabilize. Record the surrounding temperature (ambient temperature). Record the time required to stabilize \_\_\_\_\_ minutes.

**Record the stabilized oil temperature \_\_\_\_\_ °F.**

**Record the ambient temperature \_\_\_\_\_ °F.**

The "heat rise" is calculated as the stabilized temperature minus the ambient temperature.

# WEAR LIMITS

**Tool Bit**

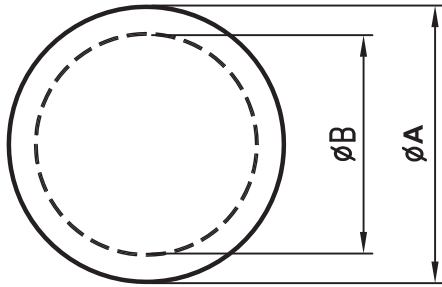

MODEL	Dimension (A) of new part	Wear Limit Dimension (B)
MBX15	85 mm/3.346 in.	80 mm/3.149 in.

**Tool Retainer Pin**

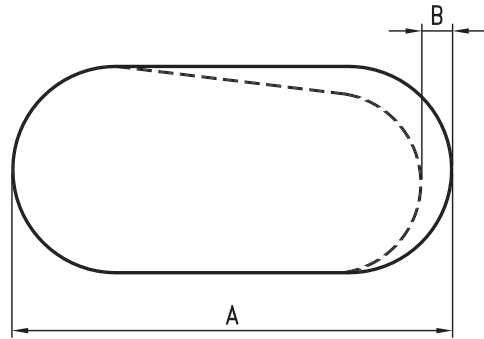

MODEL	Dimension (A) of new part	Wear Limit Dimension (B)
MBX15	54 mm/2.125 in.	3 mm/0.118 in.

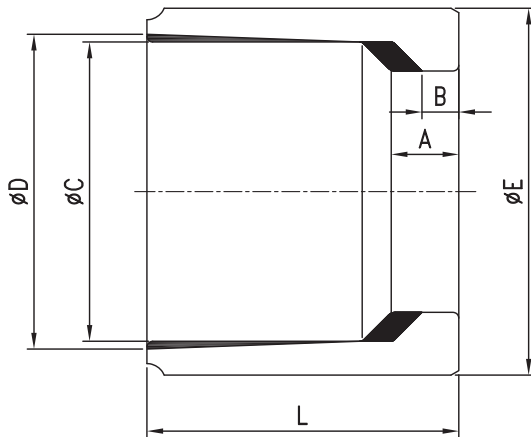

**Tool Stop**

	MBX15
(A) New Part	25 mm/0.984 in.
(B) Wear Limit	22 mm/0.866 in.
(C) New Part	85 mm/3.346 in.
(D) Wear Limit	90 mm/3.543 in.
(E)	103 mm/4.055 in.
(L)	107 mm/4.212 in.

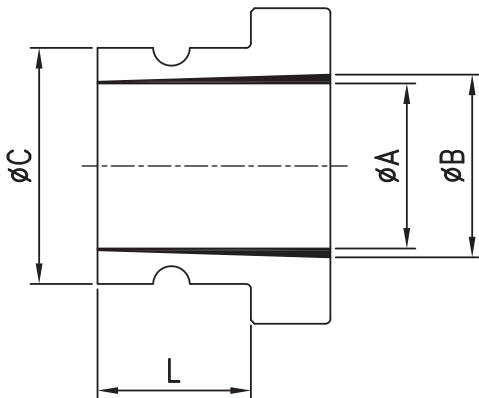

**Tool Retainer Pin**

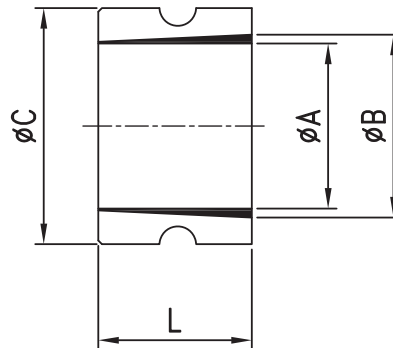

	MBX15
(A) New Part	85 mm/3.346 in.
(B) Wear Limit	90 mm/3.543 in.
(C)	121 mm/4.763 in.
(L)	90 mm/3.543 in.

# SPECIFICATIONS

		MBX15
Impact Energy Class	ft lbs J	1500 2030
Blows Per Minute	bpm	400-800
Flow Range	GPM LPM	15-25 56-95
Hydraulic Operating Pressure	psi bar	1885-2200 130-152
System Relief Pressure (minimum cracking)	psi bar	3000 206
Oil Temperature (max)	F C	176 °F 80 °C
Hose Diameter (min)	inch mm	3/4 19
Adapter Fitting Size & Type		Male JIC 37° Flare 1-1/16 × 12 UNF
Weight (w/Tool Bit)	lbs kg	1168 531
Length (w/Tool Bit)	inch mm	69 1760
Tool Diameter	inch mm	3.3 85
Tool Working Length	inch mm	16.6 426
Main Accumulator Charge Pressure	psi bar	247 +/- 7 17 +/- 0.5
Sound Power Level (LW)	dBA	126
Carrier Size	lb kg	14000-26000 6300-11800

**NOTE:**

Weights, dimensions and operating specifications listed on this sheet are subject to change without notice. Where specifications are critical to your application, please consult the factory.

## ACCESSORIES

Attaching Kits.....	Consult Dealer
Charge Hose Assy (Valve, Hose, for nitrogen tank & charge valve connections).....	505232
Adapter Assy (Required to charge main accumulator).....	33300
Adapter (Short) (Required to Charge Main Accumulator on MBX15).....	33464
Charge Adapter Kit (Includes 33300 & 33464).....	33465
Charge Kit Assembly (Includes 505232 hose, 28257 Tester, and 372047 Box).....	34892
Accumulator Tester.....	28257



# MBX15 POWER CELL ILLUSTRATION

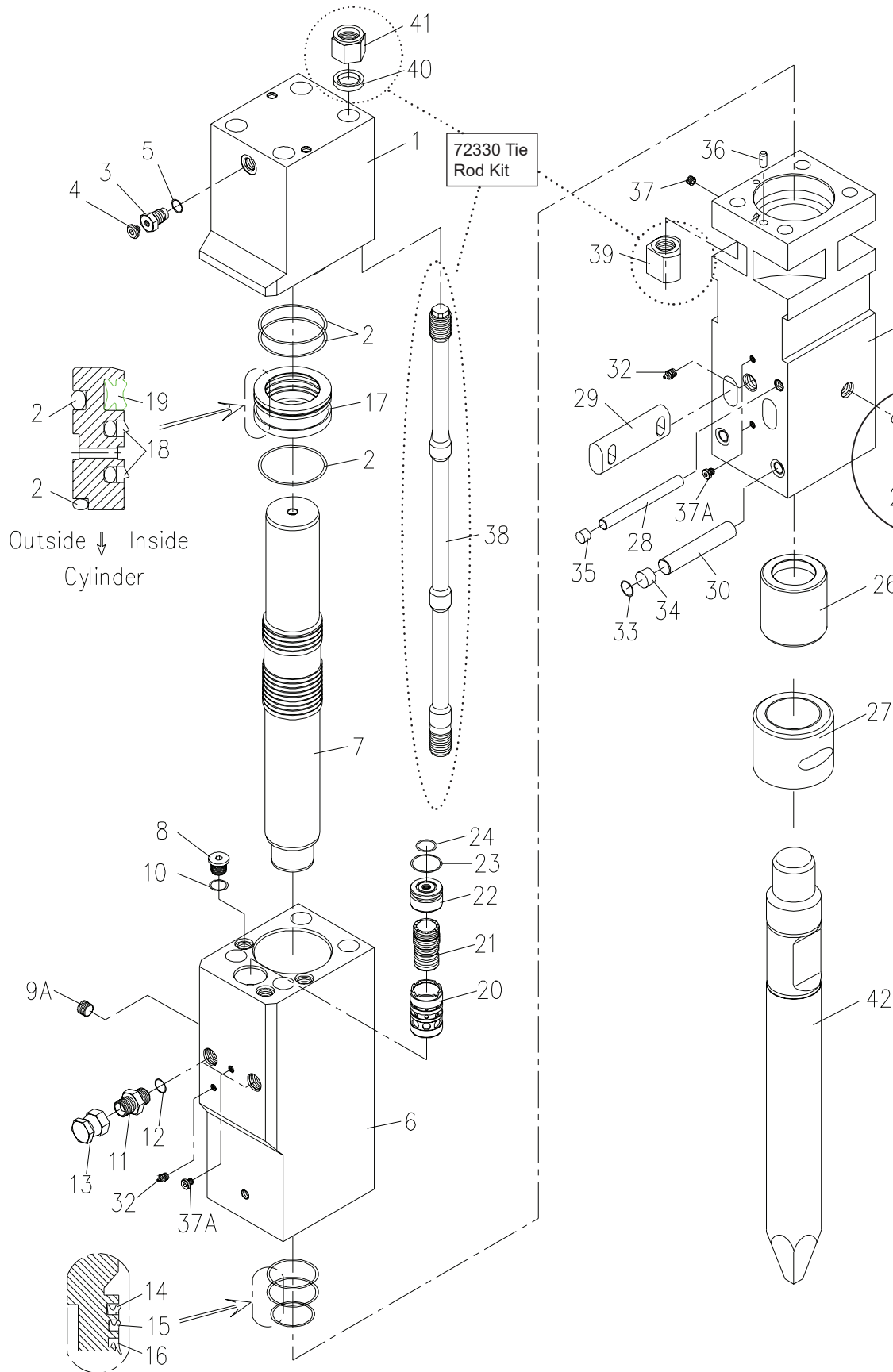

## IMPORTANT

When installing the tool retainer pin (item 28) make sure the rubber plug (item 35) is fully seated. The rubber plug **MUST** be installed **BELOW FLUSH** to properly secure the pin.

**NOTE:** If you have the new style housing (see page 27) items 28 & 35 are no-longer needed. Items 28 & 35 hold in the tool retainer pins (item 29) on the old style housing, The new style housing the tool retainer pins are captured between plates.

# MBX15 POWER CELL PARTS LIST

ITEM	P/N	QTY	DESCRIPTION
1	71592	1	MAIN ACCUMULATOR
2	71593	3	O-RING
3	68679	2	CHARGE VALVE
4	68680	2	PLUG
5	68681	2	O-RING
6	71594	1	CYLINDER
7	71595	1	PISTON
8	71596	3	PLUG
9A	68685	1	PLUG
10	71598	3	O-RING
11	68688	2	ADAPTER
12	68689	2	O-RING
13	68690	2	ADAPTER CAP
14	71599	1	BUFFER SEAL
15	71600	1	SEAL, U-CUP
16	71601	1	SEAL DUST
17	71602	1	SEAL CARRIER
18	71603	2	SEAL, STEP
19	71604	1	SEAL, GAS
20	71605	1	VALVE SLEEVE
21	71606	1	VALVE
22	71607	1	VALVE PLUG
23	71608	1	O-RING
24	71609	1	O-RING
25	71610	1	LOWER BODY MBX15
26	71611	1	TOOL STOP
27A	71612	1	LOWER BUSHING
28	71613	2	RETAINER PIN
29	71614	2	TOOL RETAINER PIN
30	71615	2	RETAINER PIN
32	68711	3	GREASE NIPPLE
33	71616	1	SNAP RING
34	71617	2	RUBBER PLUG
35	71618	2	RUBBER PLUG
36	68687	2	DOWEL PIN
37A	69102	4	PLUG
	72330	1	TIE ROD KIT (INCL ITEMS 38 THRU 41)
38	71619	4	TIE ROD MBX15
39	71620	4	LOWER TIE ROD NUT
40	71621	4	TIE ROD WASHER
41	71622	4	UPPER TIE ROD NUT
42	71623	1	TOOL BIT MBX15 CONICAL

ITEM	P/N	QTY	DESCRIPTION
	71624	1	TOOL BIT MBX15 CROSS CUT CHISEL
	71625	1	TOOL BIT MBX15 LINE CUT CHISEL
	71626	1	TOOL BIT MBX15 BLUNT
	71627	1	TOOL BIT MBX15 MOIL
	71628	1	SEAL KIT

# MBX15 HOUSING PARTS

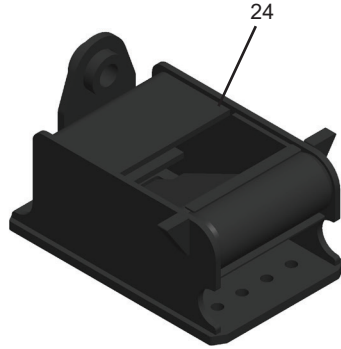

Wain Roy 1/4 yd. Mounting  
Bracket Part No. 39056

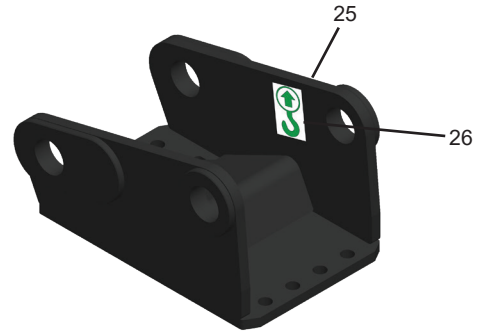

14 in. Pin Centers Mounting  
Bracket Part No. 30913

72331 Housing Flange Bolt  
Kit: Includes (Qty-16 of item 1)  
(Qty-8 of item 2) & (Qty-8 of  
item 4)

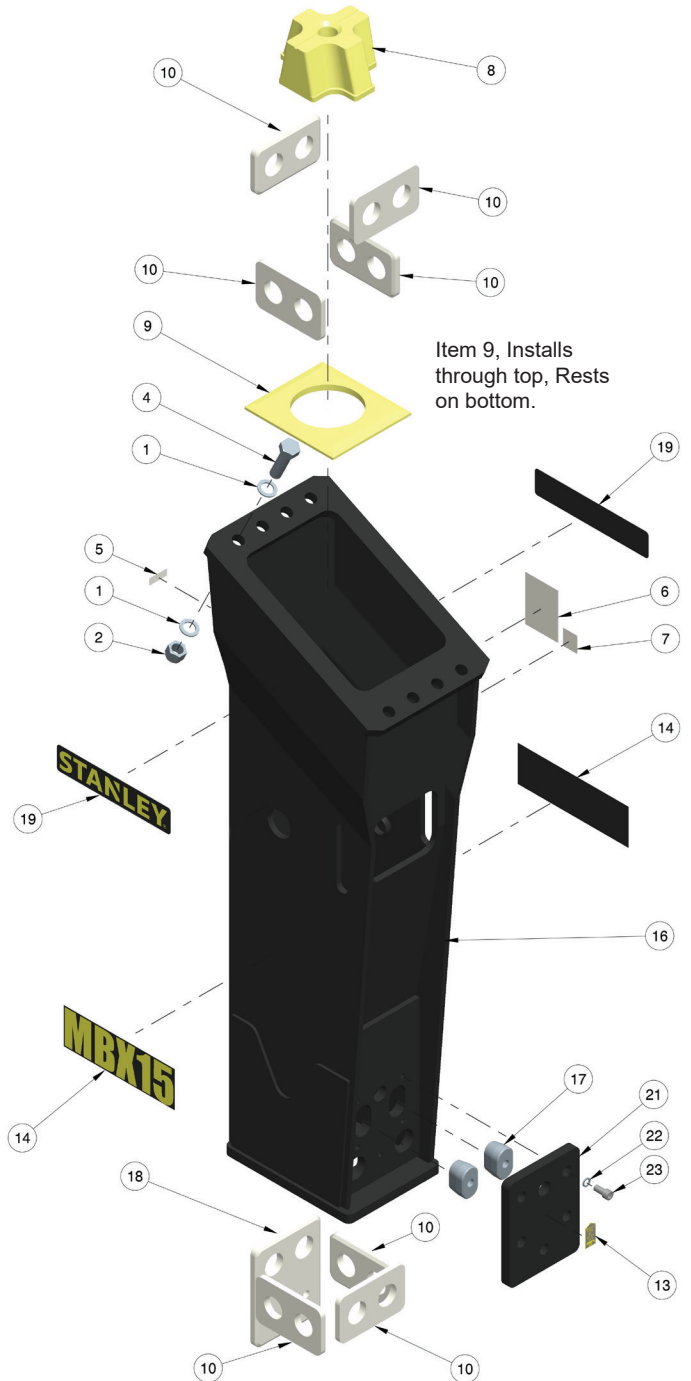

Item 9, Installs  
through top, Rests  
on bottom.

ITEM	P/N	QTY	DESCRIPTION
1	17559	16	WASHER 7/8" I.D.
2	22181	8	NYLOCK NUT 7/8-9UNC
4	30949	8	HHCS 7/8-9UNC X 3.000
5	39704	1	PRESSURE SPEC STICKER - 250 PSI
6	47351	1	DECAL, COMPOSITE WARNING
7	66218	1	GUARANTEED SOUND POWER LEVEL DECAL
8	66680	1	UPPER BUMPER
9	66681	1	LOWER BUMPER
10	66723	7	SIDE BUMPER
12	71160	1	MBX15 POWERCELL w/TOOL BIT
13	72074	1	DECAL, GREASE
14	73007	2	DECAL, MBX15
16	73692	1	HOUSING ASSY MBX15
17	73700	2	TOOL RETAINER PLUG
18	73701	1	BACK BUMPER
19	74705	2	DECAL, "STANLEY" 11 INCH
21	73697	1	TOOL PIN RETAINER PLATE
22	73699	5	SPLIT LOCKWASHER
23	73698	5	HSHCS M12-1.75 x 25
24	39056	1	WAINROY 1/4 YD BRACKET
25	30913	1	14" PIN CENTER BRACKET
26	47352	2	LIFTING POINT DECAL

**STANLEY®**

STANLEY  
3810 SE Naef Road  
Milwaukie, Oregon 97267 USA  
(800) 972-2647 / Fax (503) 652-1780