

LABOUNTY

www.stanleyinfrastructure.com/brands/labounty



MRX

MULTI-JAW DEMOLITION TOOL

MRX150, MRX200, MRX250, MRX350

PARTS MANUAL

519016 Parts Manual 3/2022 Ver. 1

PREFACE

This manual contains information for the safe operation and maintenance of the LaBounty MRX Processor. Read the entire manual before the initial start-up of the attachment. It is important to know the correct operating procedures of the attachment and all safety precautions to prevent the possibility of property damage and personal injury.

The LaBounty attachment has been designed and manufactured with high quality materials and care in workmanship. The instructions in this manual have been prepared to ensure that, when followed properly, the attachment will provide efficient and reliable service. Continuing product development and improvement may have caused changes in the attachment that are not reflected in this manual. If a question arises regarding the operation or maintenance of the attachment, contact a LaBounty dealer for the most current information available.

IMPORTANT

This operator's manual must accompany the attachment at all times and be readily available to the operator.

MANUAL REPLACEMENT

Should this manual become damaged, lost or additional copies are required, immediately contact any authorized LaBounty dealer. You may also download a PDF copy at www.stanleyinfrastructure.com.

REGISTRATION FORM

The Warranty Registration Form must be filled out by the dealer or customer and returned to LaBounty indicating the date the machine went into service.

POSSIBLE VARIATIONS

LaBounty cannot anticipate every possible circumstance that might involve a potential hazard, as the owner's requirements and equipment may vary. Therefore, the warnings in this publication and on the product may not be all-inclusive and you must ensure that the procedure, application, work method and operating technique is safe for you, and others, before operation.

PUBLIC NOTICE

LaBounty reserves the right to make changes and improvements to its products and technical literature at any time, without public notice or obligation. LaBounty also reserves the right to discontinue manufacturing any product at its discretion, at any time.

WARRANTY

All work or repairs to be considered for warranty reimbursement must be authorized by the LaBounty Service Department before work is started. Any alterations, modifications or repairs performed before authorization by the LaBounty Service Department will render all warranty reimbursement consideration null and void without exception. Improper operation or improperly performed maintenance may render any warranty null and void.



CONTENTS

SAFETY	6
MRX150	8
Body.....	8
Rotation	10
Cracker Jaw	12
Pulverizer Jaw	14
Shear Jaw	16
Shear Jaw Full Blade Kit	18
MRX200	20
Body.....	20
Rotation	22
Cracker Jaw	24
Pulverizer Jaw	26
Shear Jaw	28
Shear Jaw Full Blade Kit	29
MRX250	31
Body.....	31
Rotation	33
Cracker Jaw	35
Pulverizer Jaw	37
Shear Jaw	39
Shear Jaw Full Blade Kit	40
MRX350	42
Body.....	42
Rotation	44
Cracker Jaw	46
Pulverizer Jaw	48
Shear Jaw	50
Shear Jaw Full Blade Kit	51
HYDRAULIC SCHEMATIC	53
WEAR PART KITS	54

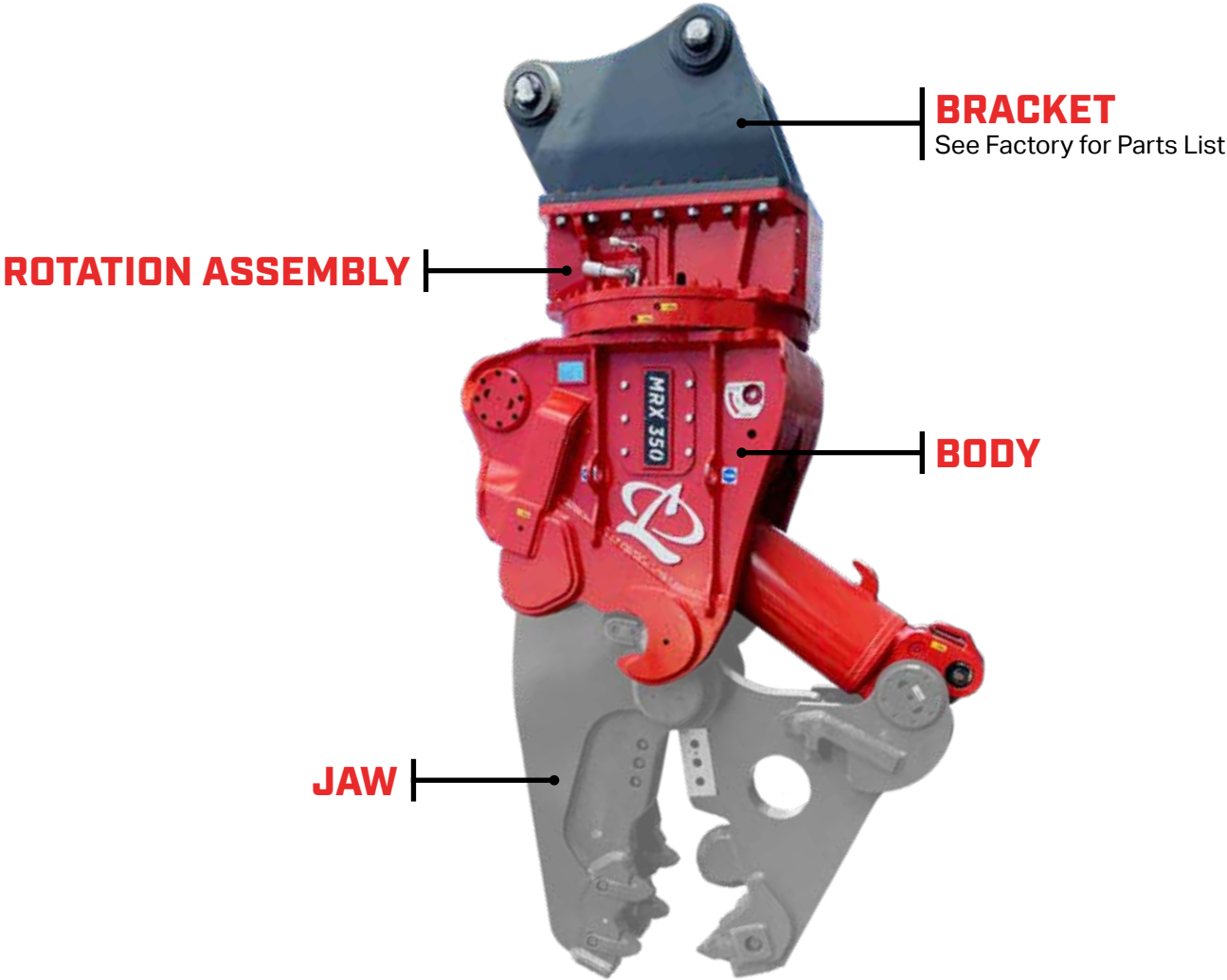
TERMS



SAFETY

	The Safety Alert Symbol alerts you to potential personal injury hazards. Obey all safety messages that follow to avoid possible injury or death.
	Indicates an imminently hazardous situation which will result in death or serious injury.
	Indicates a potentially hazardous situation which could result in death or serious injury.
	Indicates hazards that could result in damage to the equipment or personal injury
	Indicates important procedures



Your safety and the safety of others is a direct result of how you operate and maintain your equipment. Read and understand this manual and other safety information provided with the base machine and be sure that you understand all controls and operating

instructions before attempting to operate this equipment. Failure to follow the safety precautions can result in personal injury, death or property damage.

Carefully read all safety messages in this manual and on your equipment safety signs. Keep safety signs in good condition. Replace missing or damaged safety signs.

Because LaBounty cannot foresee all hazardous circumstances, the precautions listed in this manual and on the equipment are not all-inclusive. If a procedure, method, tool or part is not specifically recommended by LaBounty, determine whether it is safe for you and others, and that the equipment will not be damaged or made unsafe as a result of your decision to implement it.

The basic rules are summarized in this section of the manual. They also appear throughout the manual along with additional specific rules for safety and operation.

GENERAL

- If the attachment is not functioning properly, shut down the machine, follow proper Lock-out / Tag-out procedures and follow proper repair procedures.
- Remove and replace any damaged or worn parts

with parts recommended by LaBounty. Use of parts that are not factory approved may cause damage or unnecessary downtime and may void the warranty.

- NEVER operate equipment without the original safety guards in place.
- DO NOT process material with the attachment over the operator's cab. Doing so will result in severe personal injury or death from falling debris.
- DO NOT attempt to process brittle materials, such as axles and railroad rail. DO NOT process any material in a position that may propel it toward the operator, other workers, buildings or equipment.
- Clear all persons and equipment from the area of operation and machine movement. NEVER move loads over people or equipment. When viewing the operation of the attachment, maintain a safe distance of at least 75 feet (23 meters).
- NEVER approach power lines with any part of the machine. Keep clear at a minimum of 15 feet (5 meters).
- DO NOT close the attachment on a structure and reverse the excavator in an attempt to pull down material.
- Use of this tool on certain materials could generate dust potentially containing a variety of hazardous substances, such as, asbestos, silica or lead. Inhalation of dust containing these, or other hazardous substances could result in serious injury, cancer or death. Protect yourself and those around you. Research and understand the materials you are processing. Follow safety procedures and comply with all applicable national, state or provisional health

and safety regulations relating to them. If appropriate, arrange for the safe disposal of the materials by a qualified person.

- Disassembly of any pin-connected attachment can be hazardous. NEVER remove any pin unless the attachment is on the ground and blocked up. Serious injury or death could result. Metal chips or debris may fly when a connecting pin is struck. Use a brass drift when striking pins and always wear protective clothing and proper eye protection. Pins may fly when struck with force to drive them in or out. Always keep people clear when removing or installing pins.
- Do not operate this, or any other equipment, under the influence of drugs or alcohol.
- DO NOT modify LaBounty equipment without factory authorization. This equipment is designed to do a specific job and alterations could result in injury.
- ALWAYS lower the boom to the ground before leaving the cab. If it is necessary to work on an attachment off the ground, securely support the machine and attachment. DO NOT support the machine on cinder blocks, hollow tiles or props that may crumble under continuous load. DO NOT rely on a cylinder to hold the attachment in the air. If a control is moved or hydraulic pressure is otherwise released, the attachment may drop. DO NOT work under a machine that is supported only by a jack.
- DO NOT weld on any structural member unless specifically authorized by LaBounty. Unauthorized welding will void the warranty, may cause structural failure and could result in personal injury.
- Keep clear of potential pinch points, including the moving upper jaw, cylinder connections, bucket linkages and other moving parts.
- Before operating the attachment, read and observe all safety instructions in the Operation & Maintenance manual. If you are unfamiliar with any operation or maintenance procedure, seek instruction before proceeding.
- Inspect the attachment daily. Do not operate a poorly maintained or damaged attachment.
- Never operate a machine if an unsafe condition exists. Attach a "Do Not Operate" tag to the machine.

BASE MACHINE

- Ensure that the cab is equipped with the proper safety guards for LaBounty applications. The cab MUST be equipped with an approved Falling Object Protection Structure (FOPS) and cab guarding. The FOPS must meet the requirements of SAE standard J1356. A transparent, shatter-resistant shield covering the front of the cab, is also required. Contact your base machine equipment dealer or manufacturer for more information on the availability of FOPS and cab guarding. Lack of proper FOPS and guards may result in injury or death.

- Avoid tipping. The attachment will alter the lift capacities of the base machine. DO NOT overload the excavator or serious injury could result. Lift capacities will vary if the base machine is not on level ground. Lifting incorrectly can cause severe injury or machine damage. Use the recommended excavator counterweight. Use short slings and lift the load only as high as necessary.
- DO NOT allow riders on the machine. Riders are subject to serious injuries, such as being struck by foreign objects or being thrown off the machine. Riders also distract and obstruct the operator, resulting in the machine being operated in an unsafe manner. NEVER use the attachment as a work platform or personnel carrier.
- Check ground conditions before operating. Avoid unstable or slippery areas and position the base machine on firm, level ground. If level ground is not possible, position the base machine to use the attachment to the front or back of the carrier. Avoid working over the side of the base machine.

HYDRAULIC

- Hydraulic oil becomes hot during operation. DO NOT come in contact with hot hydraulic oil as it could cause severe burns. Wear adequate protective clothing and safety equipment.
- DO NOT tamper with hydraulic lines or components while they are pressurized. Escaping fluid under pressure can penetrate the skin, causing serious injury. Keep hands and body away from pinholes and nozzles which eject fluids under high pressure. Use a piece of cardboard to search for leaks. If ANY fluid is injected into the skin, seek immediate medical assistance.

PPE

- ALWAYS wear close-fitting clothing and safety equipment appropriate to the job. Safety equipment should be worn at all times when viewing, operating or maintaining the attachment. Safety equipment includes eye protection, hard hat, steel toe shoes, gloves, hearing protection and respirator.

MRX150

BODY

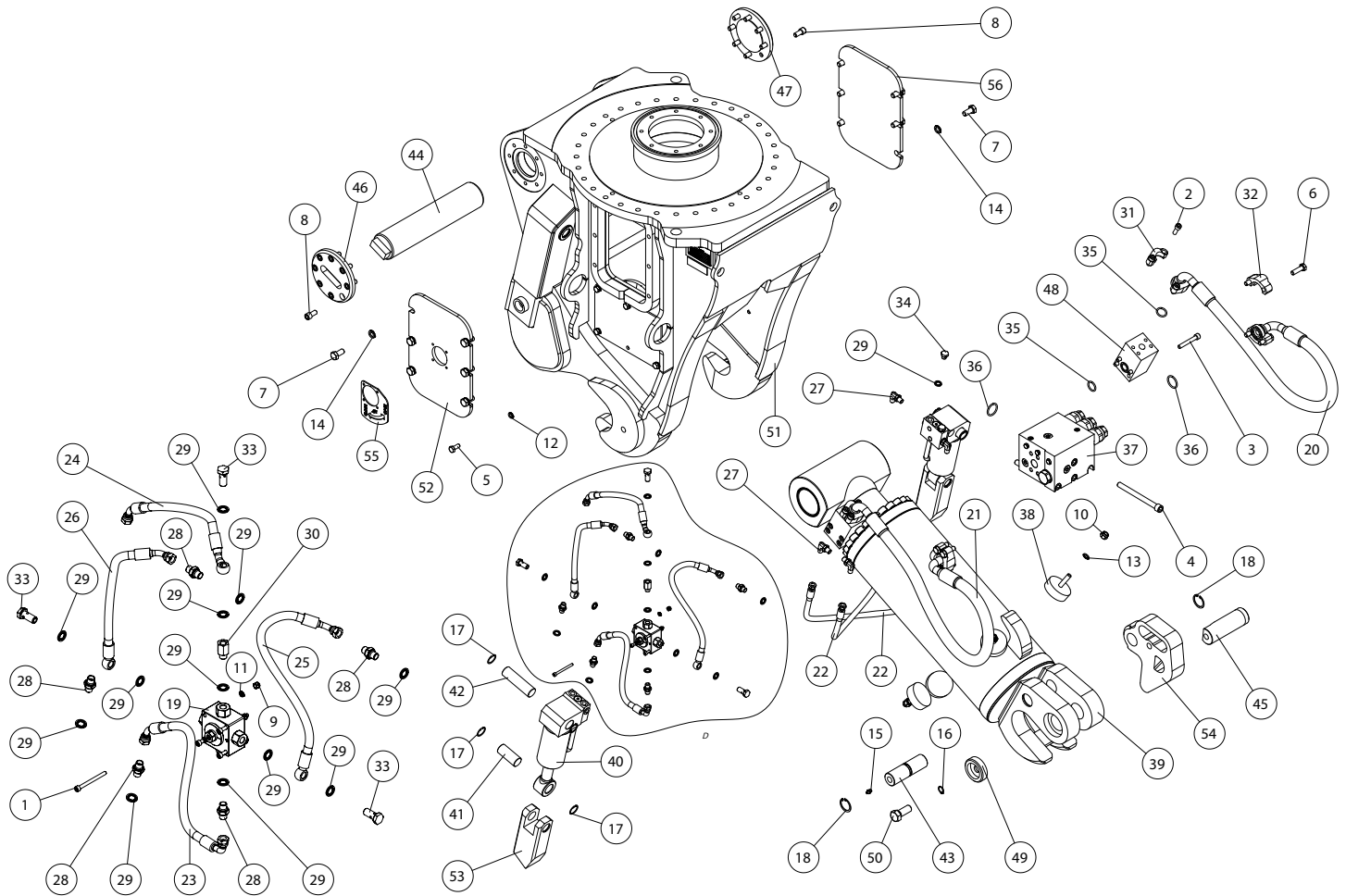

MRX150 Body Parts Illustration			
Item	Qty	Description	Part Number
1	4	SOCKET HEAD CAPSCREW	518361
2	8	SOCKET HEAD CAPSCREW	518897
3	8	SOCKET HEAD CAPSCREW	518898
4	4	SOCKET HEAD CAPSCREW	518188
5	12	HEX HEAD CAPSCREW	518192
6	8	HEX HEAD CAPSCREW	518193
7	12	HEX HEAD CAPSCREW	518195
8	16	SOCKET HEAD CAPSCREW	519155
9	4	HEX NUT W/NYLOCK	518350
10	4	HEX NUT W/NYLOCK	518351
11	4	FLAT WASHER	518352
12	12	FLAT WASHER	518353
13	4	FLAT WASHER	518354

MRX150 Body Parts Illustration

Item	Qty	Description	Part Number
14	12	FLAT WASHER	518355
15	4	GREASE ZERK	518203
16	1	C CLIP	519634
17	8	C CLIP	518358
18	2	C CLIP	518389
19	1	VALVE SWITCH	518360
20	1	HOSE ASSEMBLY	518902
21	1	HOSE ASSEMBLY	518903
22	2	HOSE ASSEMBLY	519635
23	1	HOSE ASSEMBLY	519636
24	1	HOSE ASSEMBLY	519637
25	1	HOSE ASSEMBLY	519638
26	1	HOSE ASSEMBLY	519639
27	4	HOSE ADAPTOR	518367
28	5	HOSE ADAPTOR	518368
29	14	FLAT WASHER	518308
30	1	EXTENSION ADAPTOR	518369
31	4	SPLIT FLANGE HALF	518905
32	4	SPLIT FLANGE HALF	518204
33	3	HYDRAULIC ADAPTOR PLUG	518370
34	2	HYDRAULIC ADAPTOR PLUG	518310
35	4	ORING SEAL	518906
36	4	O RING SEAL	518205
37	1	MACHINING MANIFOLD	518208
38	4	DAMPENER	518374
39	1	CYLINDER ASSEMBLY	519437
40	2	CYLINDER ASSEMBLY	518376
41	2	MACHINED PIN	518377
42	2	MACHINED PIN	518378
43	1	PIN MACHINING	519640
44	1	PIN MACHINING	519536
45	1	PIN MACHINING	519641
46	1	PIN RETAINER	518912
47	1	PIN RETAINER	518915
48	2	MANIFOLD MACHINING	518916
49	1	FLAT WASHER	519643
50	1	HEX HEAD CAPSCREW	519644
51	1	MRX 150 STICK	519645
52	1	COVER PLATE	519646
53	2	CUTTING EDGE	519647
54	1	CYLINDER RETAINER	519648
55	1	OPEN CLOSE PLATE	518386
56	1	COVER PLATE	518226

ROTATION

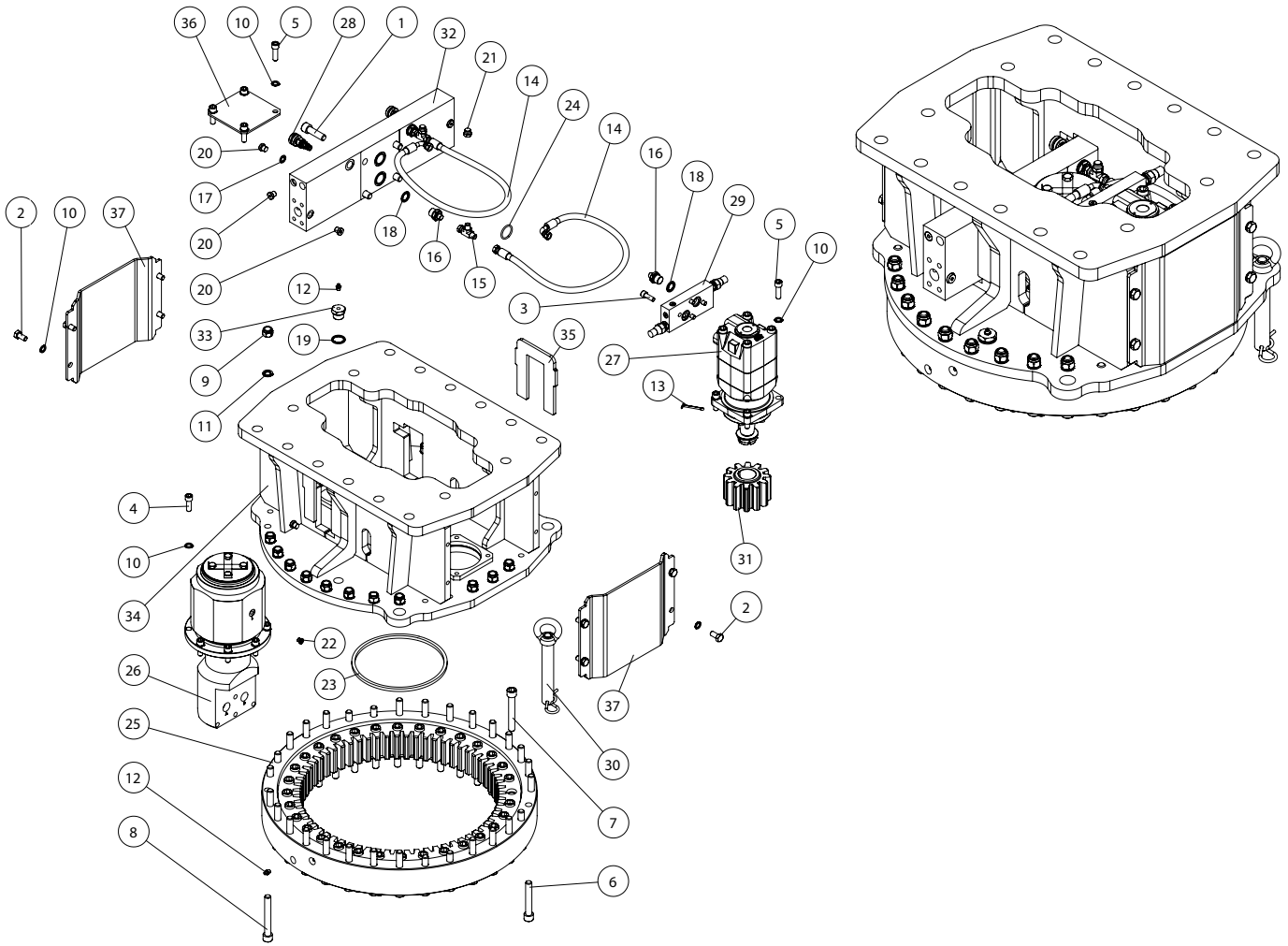

MRX150 Rotation Parts Illustration

Item	Qty	Description	Part Number
1	4	SOCKET HEAD CAPSCREW	518705
2	8	HEX HEAD CAPSCREW	518706
3	4	SOCKET HEAD CAPSCREW	518707
4	8	SOCKET HEAD CAPSCREW	518708
5	8	SOCKET HEAD CAPSCREW	518709
6	8	SOCKET HEAD CAPSCREW	518711
7	32	SOCKET HEAD CAPSCREW	518712
8	24	SOCKET HEAD CAPSCREW	518743
9	24	HEX NUT W/NYLOCK	518199
10	24	FLAT WASHER	518354
11	24	FLAT WASHER	518714
12	6	GREASE ZERK	518203
13	1	COTTER (SPLIT) PIN	518715
14	2	HYDRAULIC HOSE	518744
15	2	HOSE ADAPTOR	518745
16	4	HOSE ADAPTOR	518746
17	2	FLAT WASHER	518308
18	4	FLAT WASHER	518720
19	2	FLAT WASHER	518721
20	8	HYDRAULIC ADAPTOR PLUG	518397
21	2	HYDRAULIC ADAPTOR PLUG	518747
22	1	HYDRAULIC ADAPTOR PLUG	518371
23	1	8x8 mm GASKET	518724
24	2	O RING SEAL	518205
25	1	TURN TABLE BEARING	518749
26	1	HYDRAULIC DISTRIBUTOR	518726
27	1	HYDRAULIC MOTOR	518727
28	2	HYDRAULIC ADAPTOR	518728
29	1	MANIFOLD MACHINING	518730
30	1	HITCH PIN	518731
31	1	PINION GEAR	518732
32	1	MANIFOLD MACHINING	518733
33	2	HYDRAULIC ADAPTOR PLUG	518734
34	1	UPPERHEAD WELDMENT MACHINING	518750
35	2	SIDE PLATE	518737
36	1	COVER PLATE	518738
37	2	FORMED COVER PLATE	518751

MRX150 Cracker Jaw Parts Illustration

Item	Qty	Description	Part Number
1	14	SOCKET HEAD CAPSCREW	519569
2	2	SOCKET HEAD CAPSCREW	See "MRX Blade Kits" on page 53
3	2	SOCKET HEAD CAPSCREW	See "MRX Blade Kits" on page 53
4	1	HEX HEAD CAPSCREW	518614
5	4	CUTTING EDGE KIT	518169
6	1	CUTTING EDGE KIT	518171
7	16	SOCKET HEAD CAPSCREW	519155
8	4	SOCKET HEAD CAPSCREW	519649
9	1	HEX NUT W/NYLOCK	518419
10	4	HEX NUT W/NYLOCK	See "MRX Blade Kits" on page 53
11	2	FLAT WASHER	518304
12	2	GREASE ZERK	518203
14	1	CUTTING EDGE	518171
15	1	PIN MACHINING	519537
16	1	PIN MACHINING	519539
17	1	PIN MACHINING	519650
18	1	PIN MACHINING	519652
19	1	BEARING MACHINING	519540
20	1	BEARING MACHINING	519543
21	1	PIN RETAINER	518912
22	1	PIN RETAINER	518915
23	2	PIN RETAINER	519653
25	1	HEX NUT W/NYLOCK	518171
26	1	MRX 150 CC LOWER	519654
27	1	MRX 150 CC UPPER	519655
28	2	SPACER SHIM	519541
29	2	COVER PLATE	519656
30	2	BLADE MACHINING	See "MRX Blade Kits" on page 53
31	1	BLADE SHIM	See "MRX Blade Kits" on page 53

PULVERIZER JAW

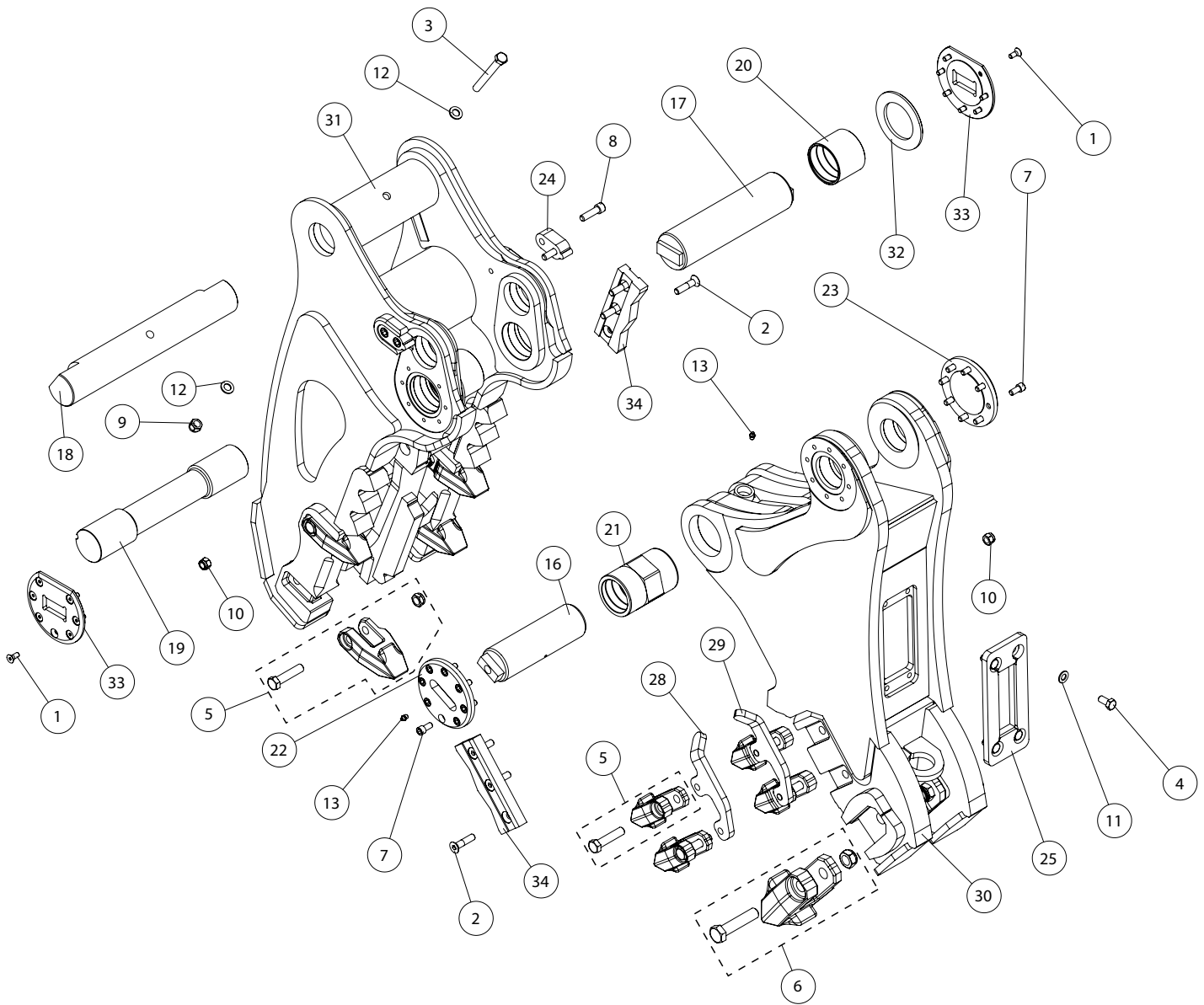

MRX150 Pulverizer Jaw Parts Illustration			
Item	Qty	Description	Part Number
1	14	SOCKET HEAD CAPSCREW	519569
2	6	SOCKET HEAD CAPSCREW	See "MRX Blade Kits" on page 53
3	1	HEX HEAD CAPSCREW	518614
4	4	HEX HEAD CAPSCREW	518195
5	8	CUTTING EDGE KIT	518169
6	2	CUTTING EDGE KIT	518170
7	16	SOCKET HEAD CAPSCREW	519155

MRX150 Pulverizer Jaw Parts Illustration

Item	Qty	Description	Part Number
8	4	SOCKET HEAD CAPSCREW	519649
9	1	HEX NUT W/NYLOCK	518419
10	6	HEX NUT W/NYLOCK	See "MRX Blade Kits" on page 53
11	4	FLAT WASHER	518202
12	2	FLAT WASHER	518304
13	2	GREASE ZERK	518203
16	1	PIN MACHINING	519537
17	1	PIN MACHINING	519539
18	1	PIN MACHINING	519650
19	1	PIN MACHINING	519695
20	2	BEARING MACHINING	518911
21	1	BEARING MACHINING	519540
22	1	PIN RETAINER	518912
23	1	PIN RETAINER	518915
24	2	PIN RETAINER	519653
25	1	COVER PLATE	518646
28	1	CUTTING EDGE	See "MRX Wear Kits" on page 53
29	1	CUTTING EDGE	See "MRX Wear Kits" on page 53
30	1	MRX 150 CP UPPER	519659
31	1	MRX 150 CP LOWER	519661
32	2	SPACER SHIM	519541
33	2	COVER PLATE	519656
34	2	CUTTING EDGE	See "MRX Blade Kits" on page 53

SHEAR JAW

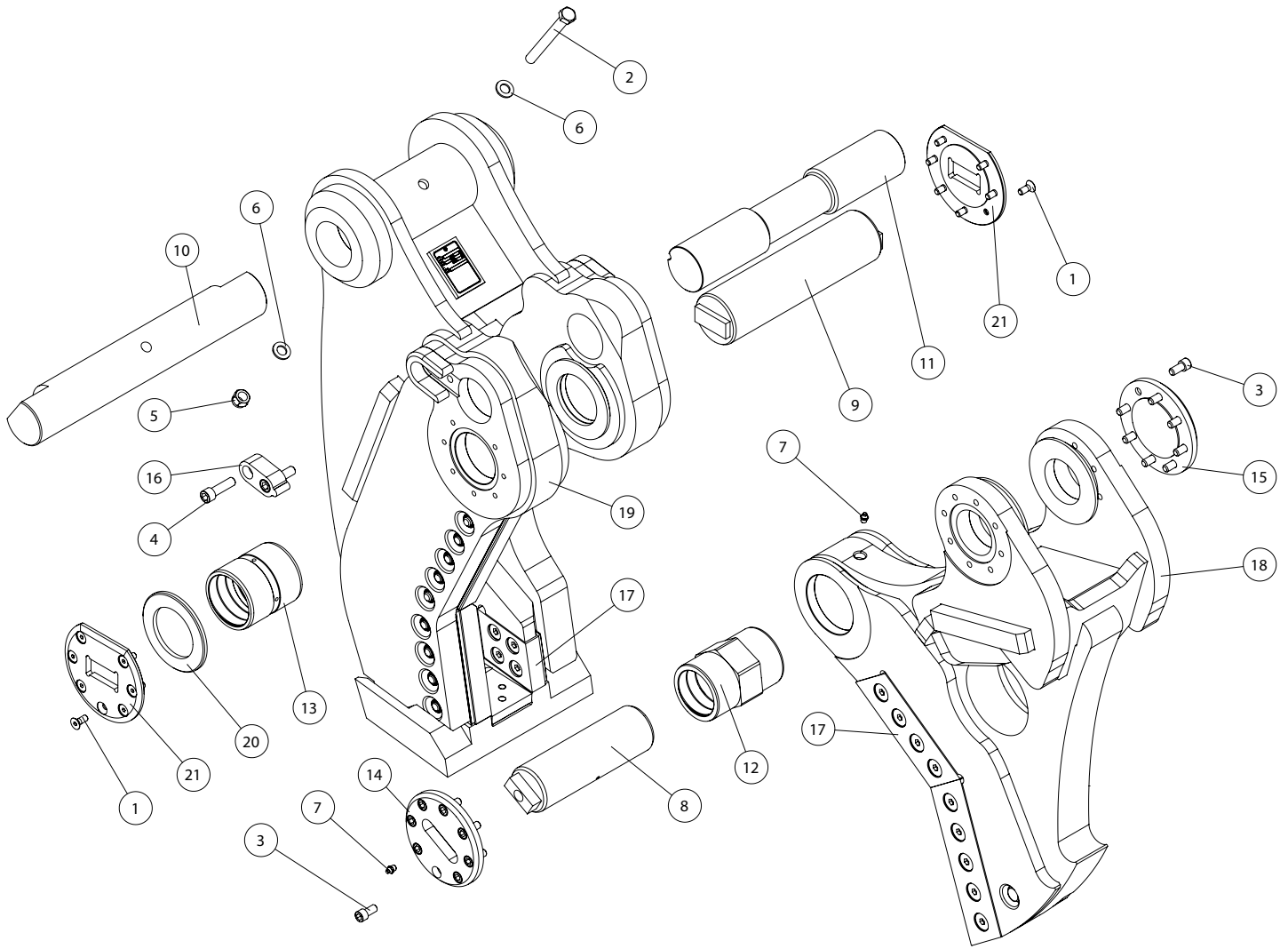

MRX150 Shear Jaw Parts Illustration			
Item	Qty	Description	Part Number
1	14	SOCKET HEAD CAPSCREW	519569
2	1	HEX HEAD CAPSCREW	518417
3	16	SOCKET HEAD CAPSCREW	519155
4	4	SOCKET HEAD CAPSCREW	519649
5	1	HEX NUT W/NYLOCK	518419
6	2	FLAT WASHER	518304
7	2	GREASE ZERK	518203
8	1	PIN MACHINING	519537
9	1	PIN MACHINING	519539
10	1	PIN MACHINING	519650
11	1	PIN MACHINING	519652
12	1	BEARING MACHINING	519540
13	1	BEARING MACHINING	519542
14	1	PIN RETAINER	518912
15	1	PIN RETAINER	518915
16	2	PIN RETAINER	519653
17	1	BLADE KIT	519383
18	1	MRX 150 SH LOWER	519662
19	1	MRX 150 SH UPPER	519663
20	2	SPACER SHIM	519541
21	2	COVER PLATE	519656

SHEAR JAW FULL BLADE KIT

Full blade kits contain all the parts of the Cutting Blade Kit and the Tip Blade Kit. Use part number 519383 for an MRX150 Shear Jaw Full Blade Kit.

Cutting Blade Kit - P/N 232543

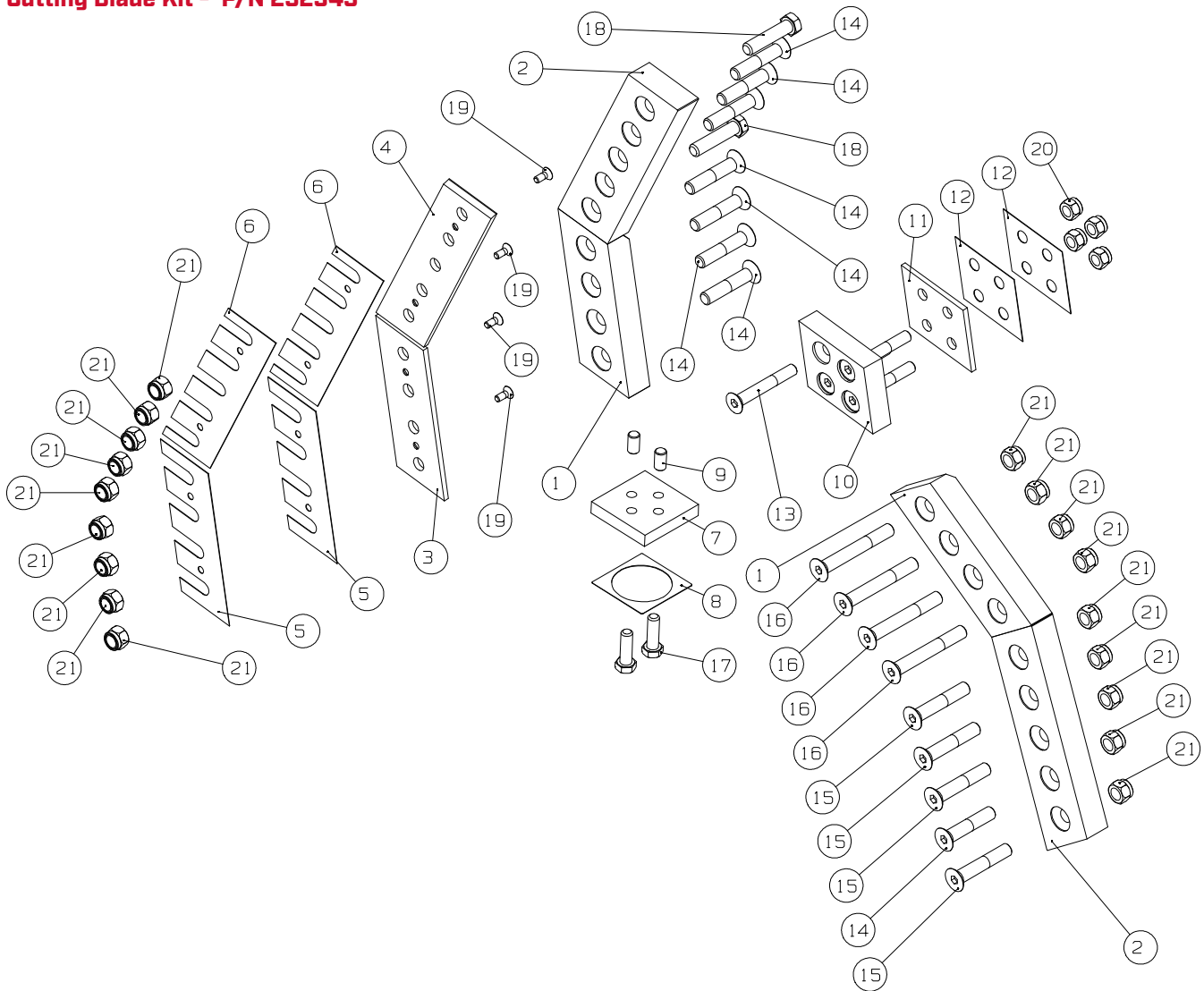

MRX150 Shear Jaw Cutting Blade Kit Parts Illustration			
Item	Qty	Description	Part Number
1	2	BLADE MACHINING	519672
2	2	BLADE MACHINING	519671
3	1	SPACER	519668
4	1	SPACER	519667
5	2	SHIM	519676
6	2	SHIM	519675
7	1	CROSS BLADE MACHINING	519670
8	1	SHIM	519674
9	2	DOWEL PIN	519287
10	1	GUIDE BLADE MACHINING	519292

MRX150 Shear Jaw Cutting Blade Kit Parts Illustration			
Item	Qty	Description	Part Number
11	1	SPACER	519289
12	2	SHIM	519298
13	4	CAPSCREW	519596
14	8	CAPSCREW	502785
15	4	CAPSCREW	502390
16	4	CAPSCREW	502999
17	2	CAPSCREW	519283
18	2	CAPSCREW	503039
19	4	CAPSCREW	518670
20	4	NUT	518901
21	18	NUT	518199

Cutting Blade Kit - P/N 232544

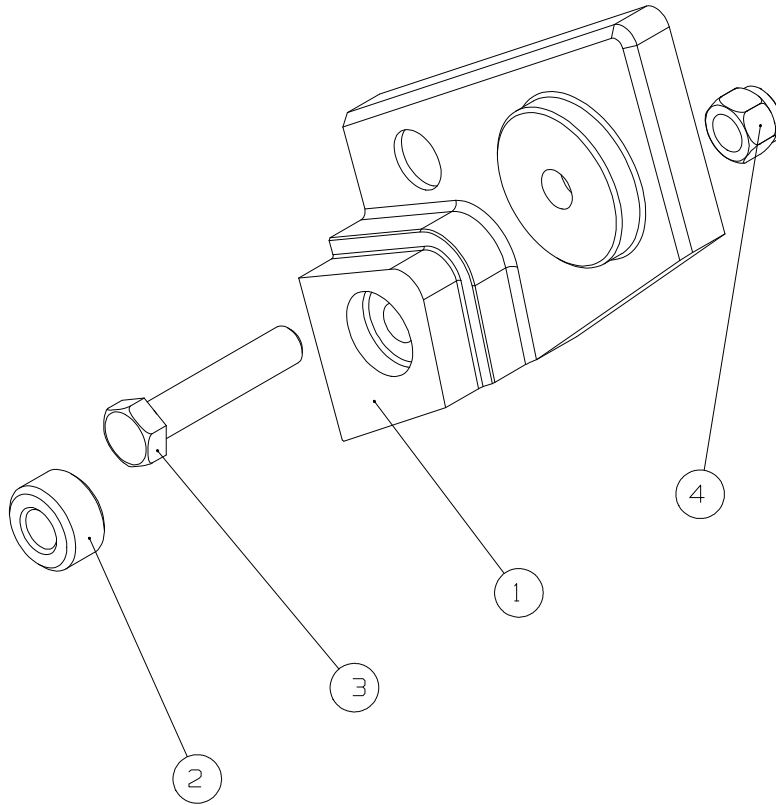

MRX150 Shear Jaw Tip Blade Kit Parts Illustration			
Item	Qty	Description	Part Number
1	1	BLADE MACHINING	519673
2	1	DOWEL PIN	519666
3	1	CAPSCREW	503039
4	1	NUT	518199

MRX200

BODY

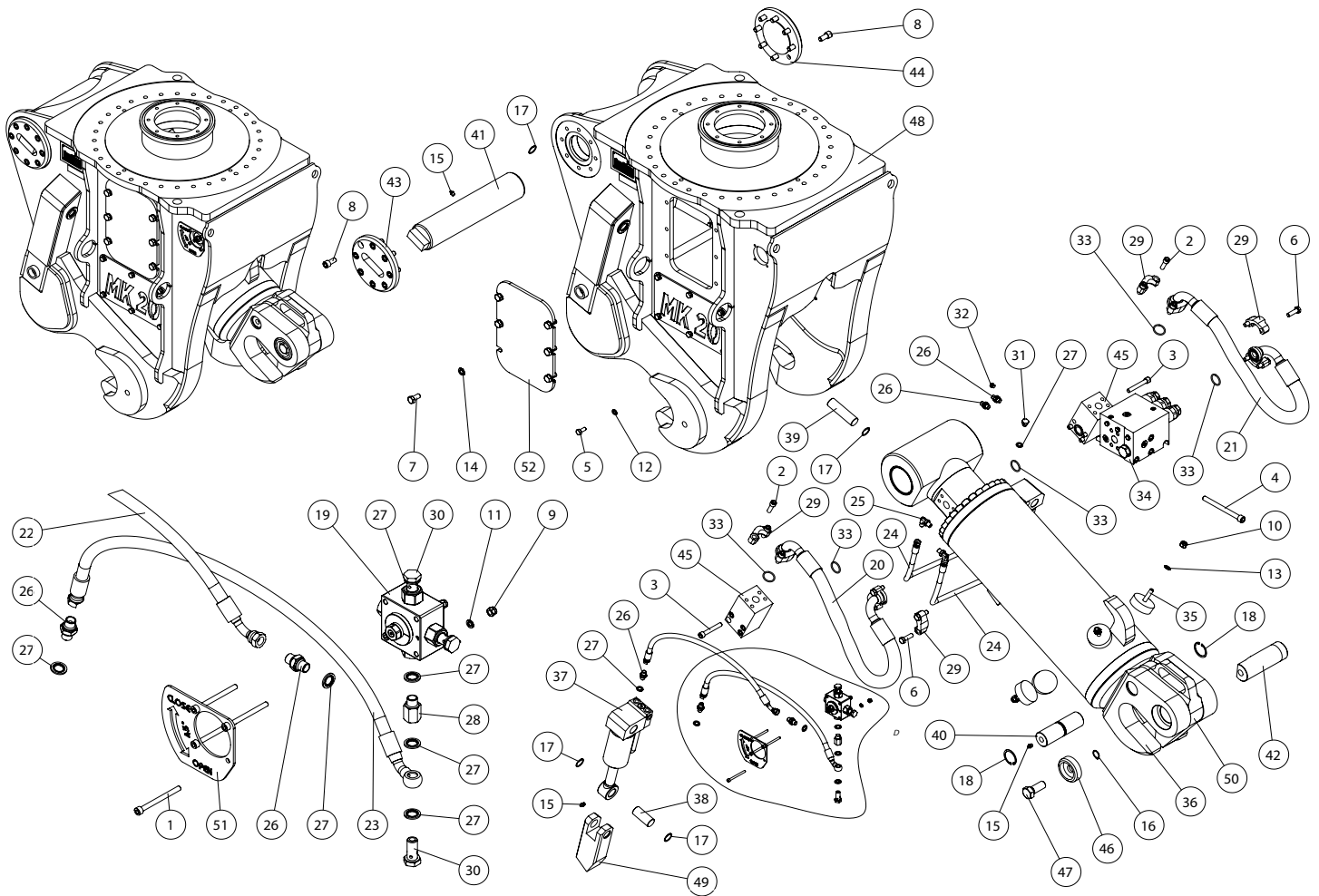

MRX200 Body Parts Illustration			
Item	Qty	Description	Part Number
1	4	SOCKET HEAD CAPSCREW	518361
2	8	SOCKET HEAD CAPSCREW	518186
3	8	SOCKET HEAD CAPSCREW	518187
4	4	SOCKET HEAD CAPSCREW	518188
5	12	HEX HEAD CAPSCREW	518192
6	8	HEX HEAD CAPSCREW	518193
7	12	HEX HEAD CAPSCREW	518195
8	16	HEX NUT W/NYLOCK	518198
9	4	HEX NUT W/NYLOCK	518350
10	4	HEX NUT W/NYLOCK	518351
11	4	FLAT WASHER	518352
12	12	FLAT WASHER	518353
13	4	FLAT WASHER	518354

MRX200 Body Parts Illustration

Item	Qty	Description	Part Number
14	12	FLAT WASHER	518355
15	4	GREASE ZERK	518203
16	1	C CLIP	518357
17	8	C CLIP	518358
18	2	C CLIP	518359
19	1	VALVE SWITCH	518360
20	1	HOSE ASSEMBLY	518362
21	1	HOSE ASSEMBLY	518363
22	1	HYDRAULIC HOSE	518364
23	1	HYDRAULIC HOSE	518365
24	2	HYDRAULIC HOSE	518366
25	4	HOSE ADAPTOR	518367
26	5	HOSE ADAPTOR	518368
27	14	FLAT WASHER	518308
28	1	EXTENSION ADAPTOR	518369
29	8	SPLIT FLANGE HALF	518204
30	3	HYDRAULIC ADAPTOR PLUG	518370
31	2	HYDRAULIC ADAPTOR PLUG	518310
32	1	HYDRAULIC ADAPTOR PLUG	518371
33	8	O RING SEAL	518205
34	1	MACHINING MANIFOLD	518208
35	4	DAMPENER	518374
36	1	CYLINDER ASSEMBLY	518375
37	2	CYLINDER ASSEMBLY	518376
38	2	MACHINED PIN	518377
39	2	MACHINED PIN	518378
40	1	MACHINED PIN	518379
41	1	BEARING MACHINING	518214
42	1	MACHINED PIN	518380
43	1	PIN RETAINER	518217
44	1	PIN RETAINER	518218
45	2	MANIFOLD MACHINING	518220
46	1	FLAT WASHER	518381
47	1	HEX HEAD CAPSCREW	518382
48	1	MRX200 STICK	518383
49	2	CUTTING EDGE	518384
50	1	CYLINDER RETAINER	518385
51	1	OPEN CLOSE PLATE	518386
52	2	COVER PLATE	518226

ROTATION

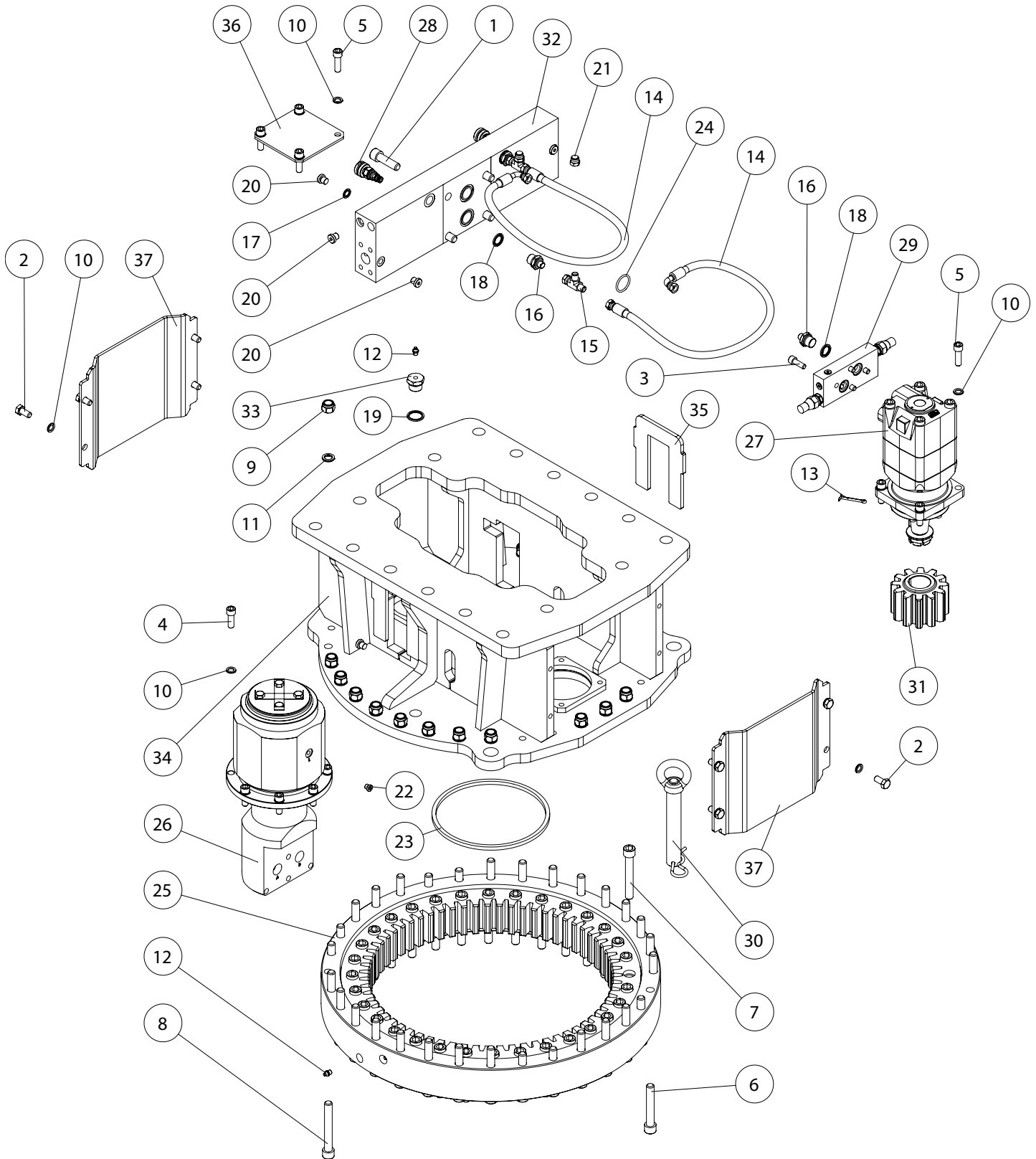

MRX200 Rotation Parts Illustration

Item	Qty	Description	Part Number
1	4	SOCKET HEAD CAPSCREW	518705
2	8	HEX HEAD CAPSCREW	518706
3	4	SOCKET HEAD CAPSCREW	518707
4	8	SOCKET HEAD CAPSCREW	518708
5	8	SOCKET HEAD CAPSCREW	518709
6	8	SOCKET HEAD CAPSCREW	518711
7	32	SOCKET HEAD CAPSCREW	518712
8	24	SOCKET HEAD CAPSCREW	518743
9	24	HEX NUT W/NYLOCK	518199
10	24	FLAT WASHER	518354
11	24	FLAT WASHER	518714
12	6	GREASE ZERK	518203
13	1	COTTER (SPLIT) PIN	518715
14	2	HYDRAULIC HOSE	518744
15	2	HOSE ADAPTOR	518745
16	4	HOSE ADAPTOR	518746
17	2	FLAT WASHER	518308
18	4	FLAT WASHER	518720
19	2	FLAT WASHER	518721
20	8	HYDRAULIC ADAPTOR PLUG	518397
21	2	HYDRAULIC ADAPTOR PLUG	518747
22	1	HYDRAULIC ADAPTOR PLUG	518371
23	1	8x8 mm GASKET	518724
24	2	O RING SEAL	518205
25	1	TURN TABLE BEARING	518749
26	1	HYDRAULIC DISTRIBUTOR	518726
27	1	HYDRAULIC MOTOR	518727
28	2	HYDRAULIC ADAPTOR	518728
29	1	MANIFOLD MACHINING	518730
30	1	HITCH PIN	518731
31	1	PINION GEAR	518732
32	1	MANIFOLD MACHINING	518733
33	2	HYDRAULIC ADAPTOR PLUG	518734
34	1	UPPERHEAD WELDMENT MACHINING	518750
35	2	SIDE PLATE	518737
36	1	COVER PLATE	518738
37	2	FORMED COVER PLATE	518751

CRACKER JAW

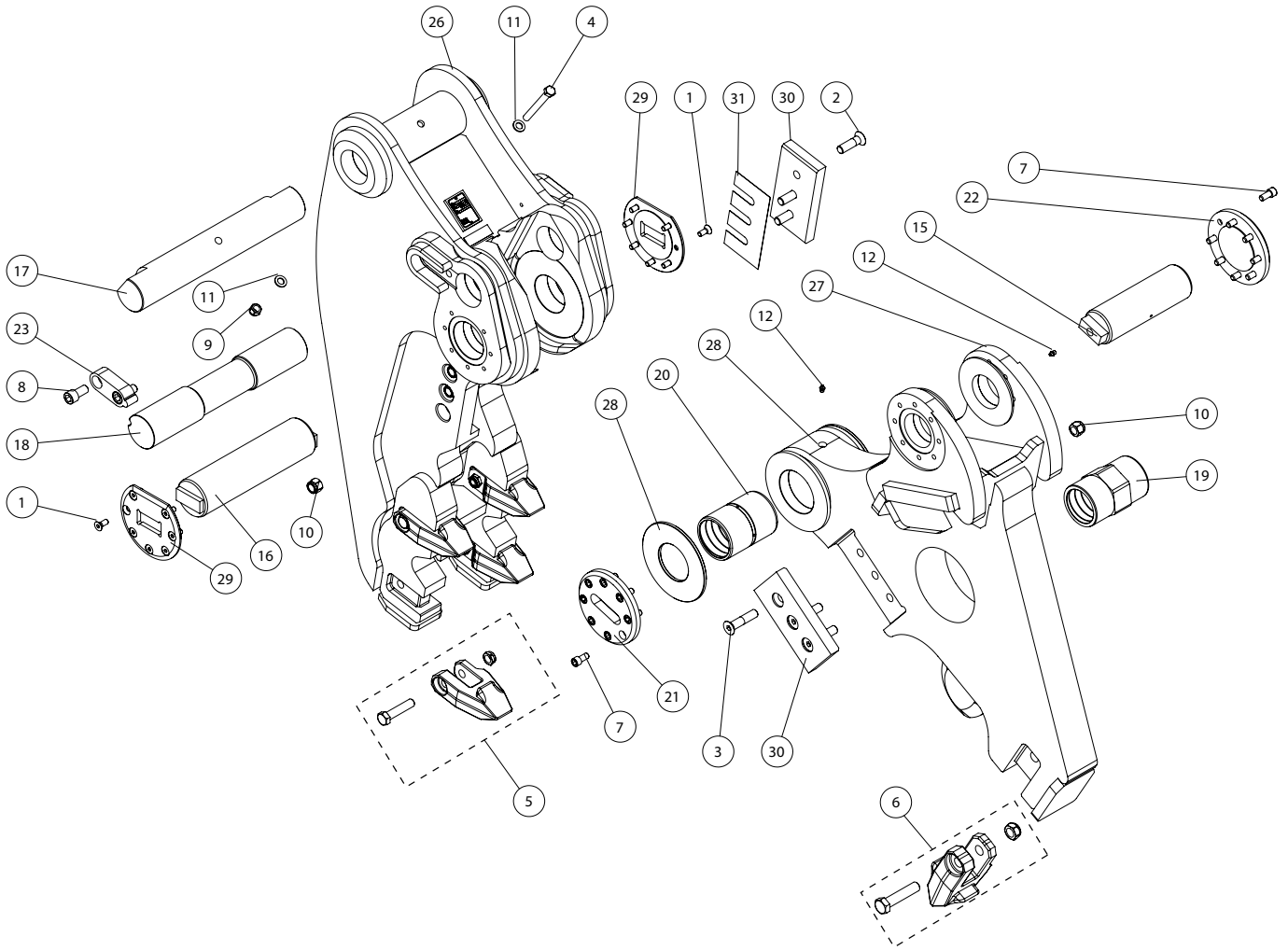

MRX200 Cracker Jaw Parts Illustration

Item	Qty	Description	Part Number
1	14	SOCKET HEAD CAPSCREW	518416
2	3	SOCKET HEAD CAPSCREW	See "MRX Blade Kits" on page 53
3	3	SOCKET HEAD CAPSCREW	See "MRX Blade Kits" on page 53
4	1	HEX HEAD CAPSCREW	518614
5	4	CUTTING EDGE KIT	518171
6	1	CUTTING EDGE KIT	518170
7	16	HEX NUT W/NYLOCK	518198
8	4	HEX HEAD CAPSCREW	518433
9	1	HEX NUT W/NYLOCK	518419
10	6	HEX NUT W/NYLOCK	See "MRX Blade Kits" on page 53
11	2	FLAT WASHER	518304
12	2	GREASE ZERK	518203
15	1	PIN MACHINING	518420
16	1	PIN MACHINING	518421
17	1	PIN MACHINING	518422
18	1	PIN MACHINING	518423
19	1	BEARING MACHINING	518424
20	1	BEARING MACHINING	518620
21	1	PIN RETAINER	518217
22	1	PIN RETAINER	518218
23	2	PIN RETAINER	518426
26	1	LOWER WELDMENT MACHINING	518623
27	1	UPPER WELDMENT MACHINING	518624
28	2	SPACER SHIM	518429
29	2	SPACER SHIM	518430
30	2	BLADE MACHINING	See "MRX Blade Kits" on page 53
31	1	BLADE SHIM	See "MRX Blade Kits" on page 53

PULVERIZER JAW

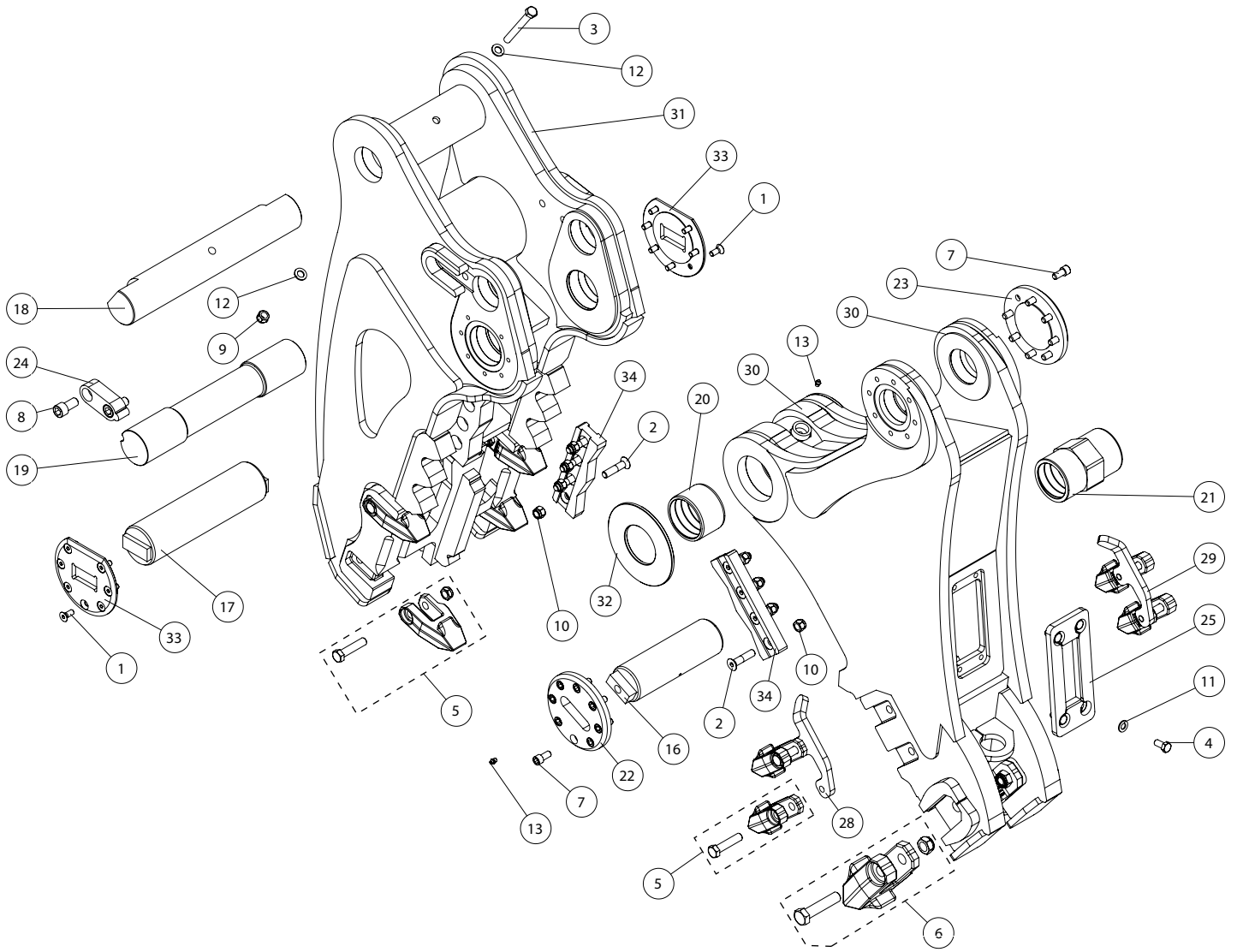

MRX200 Pulverizer Jaw Parts Illustration

Item	Qty	Description	Part Number
1	14	SOCKET HEAD CAPSCREW	518416
2	8	HEX HEAD CAPSCREW	See "MRX Blade Kits" on page 53
3	1	HEX HEAD CAPSCREW	518614
4	4	HEX HEAD CAPSCREW	518195
5	8	CUTTING EDGE KIT	518169
6	2	CUTTING EDGE KIT	518170
7	16	HEX NUT W/NYLOCK	518198
8	4	HEX HEAD CAPSCREW	518433
9	1	HEX NUT W/NYLOCK	518419
10	8	HEX NUT W/NYLOCK	See "MRX Blade Kits" on page 53
11	4	FLAT WASHER	518202
12	2	FLAT WASHER	518304
13	2	GREASE ZERK	518203
16	1	PIN MACHINING	518420
17	1	PIN MACHINING	518421
18	1	PIN MACHINING	518422
19	1	PIN MACHINING	518644
20	2	BEARING MACHINING	518645
21	1	BEARING MACHINING	518424
22	1	PIN RETAINER	518217
23	1	PIN RETAINER	518218
24	2	PIN RETAINER	518426
25	1	COVER PLATE	518646
28	1	CUTTING EDGE	518649
29	1	CUTTING EDGE	518650
30	1	UPPER WELDMENT MACHINING	518651
31	1	LOWER WELDMENT MACHINING	518652
32	2	SPACER SHIM	518429
33	2	SPACER SHIM	518430
34	2	BLADE MACHINING	See "MRX Blade Kits" on page 53

SHEAR JAW

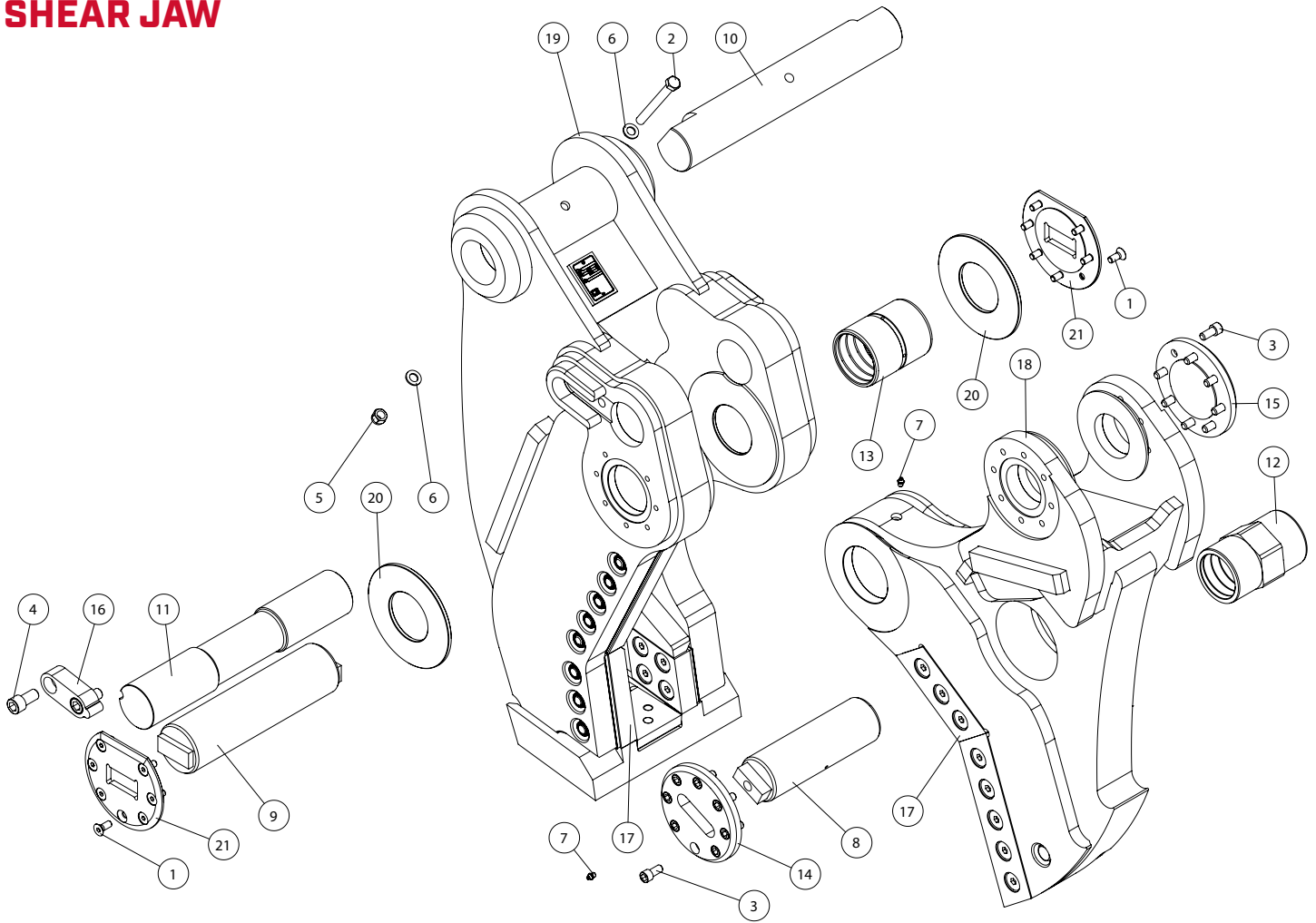

MRX200 Shear Jaw Parts Illustration			
Item	Qty	Description	Part Number
1	14	SOCKET HEAD CAPSCREW	518416
2	1	HEX HEAD CAPSCREW	518417
3	16	HEX NUT W/NYLOCK	518198
4	4	HEX HEAD CAPSCREW	518433
5	1	HEX NUT W/NYLOCK	518419
6	2	FLAT WASHER	518304
7	2	GREASE ZERK	518203
8	1	PIN MACHINING	518420
9	1	PIN MACHINING	518421
10	1	PIN MACHINING	518422
11	1	PIN MACHINING	518423
12	1	BEARING MACHINING	518424
13	1	BEARING MACHINING	518425
14	1	PIN RETAINER	518217

MRX200 Shear Jaw Parts Illustration			
Item	Qty	Description	Part Number
15	1	PIN RETAINER	518218
16	2	PIN RETAINER	518426
17	1	MRX200 BLADE KIT	518174
18	1	UPPER WELDMENT MACHINING	518427
19	1	LOWER WELDMENT MACHINING	518428
20	2	SPACER SHIM	518429
21	2	SPACER SHIM	518430

SHEAR JAW FULL BLADE KIT

Full blade kits contain all the parts of the Cutting Blade Kit and the Tip Blade Kit. Use part number 518174 for an MRX200 Shear Jaw Full Blade Kit.

Cutting Blade Kit - P/N 232546

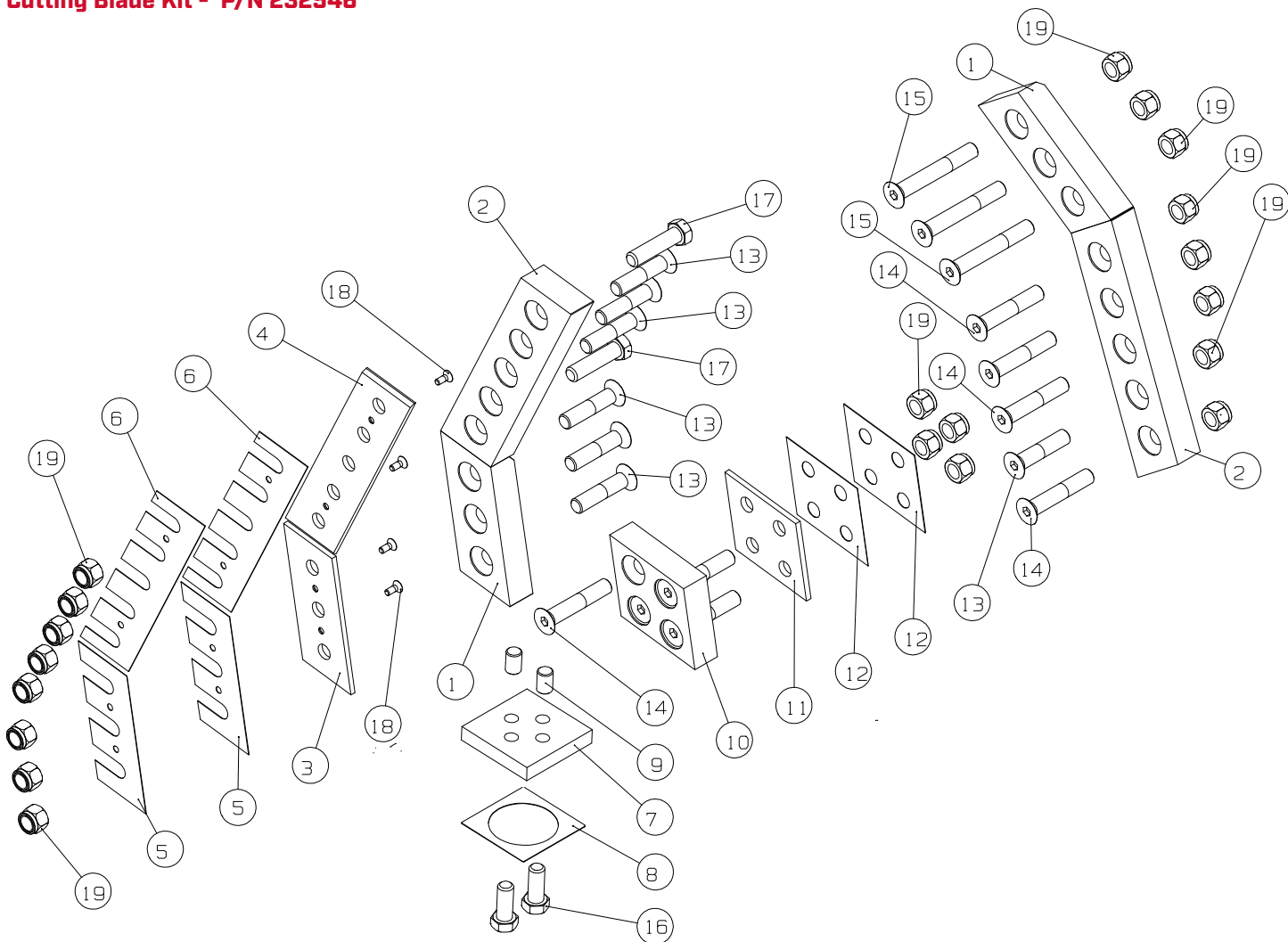

MRX200 Shear Jaw Cutting Blade Kit Parts Illustration			
Item	Qty	Description	Part Number
1	2	BLADE MACHINING	518681
2	2	BLADE MACHINING	518677
3	1	SPACER	518676
4	1	SPACER	518673
5	2	SHIM	518686
6	2	SHIM	518682
7	1	CROSS BLADE MACHINING	518679
8	1	SHIM	518685
9	2	DOWEL PIN	518671
10	1	GUIDE BLADE MACHINING	518678

MRX200 Shear Jaw Cutting Blade Kit Parts Illustration			
Item	Qty	Description	Part Number
11	1	SPACER	518675
12	2	SHIM	518684
13	7	CAPSCREW	502392
14	8	CAPSCREW	502046
15	3	CAPSCREW	518667
16	2	CAPSCREW	502358
17	2	CAPSCREW	510869
18	4	CAPSCREW	518670
19	20	NUT	518200

Tip Blade Kit - P/N 232547

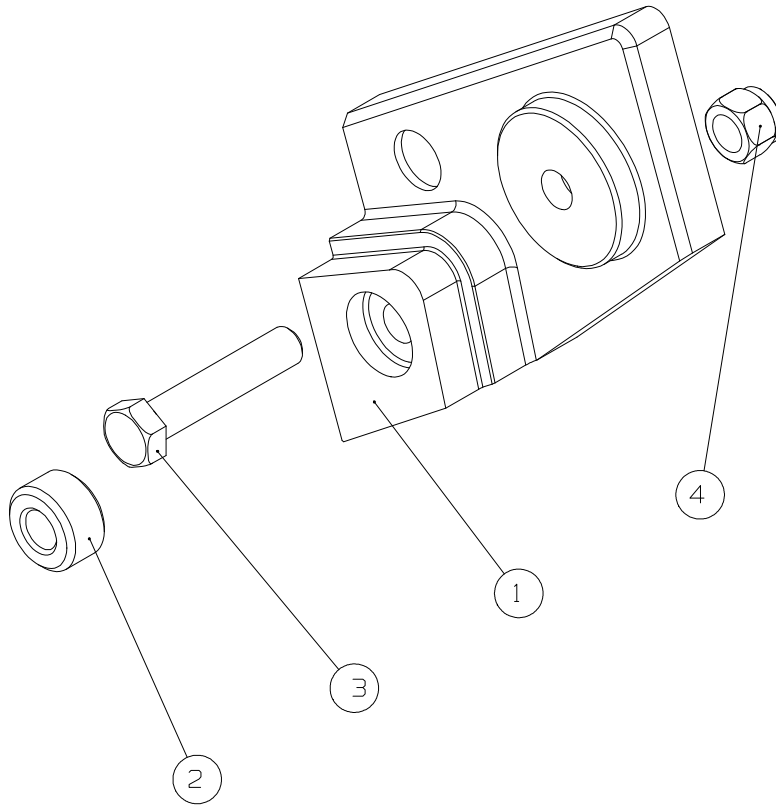

MRX200 Shear Jaw Tip Blade Kit Parts Illustration			
Item	Qty	Description	Part Number
1	1	BLADE MACHINING	518680
2	1	DOWEL PIN	518672
3	1	CAPSCREW	502492
4	1	NUT	518200

MRX250

BODY

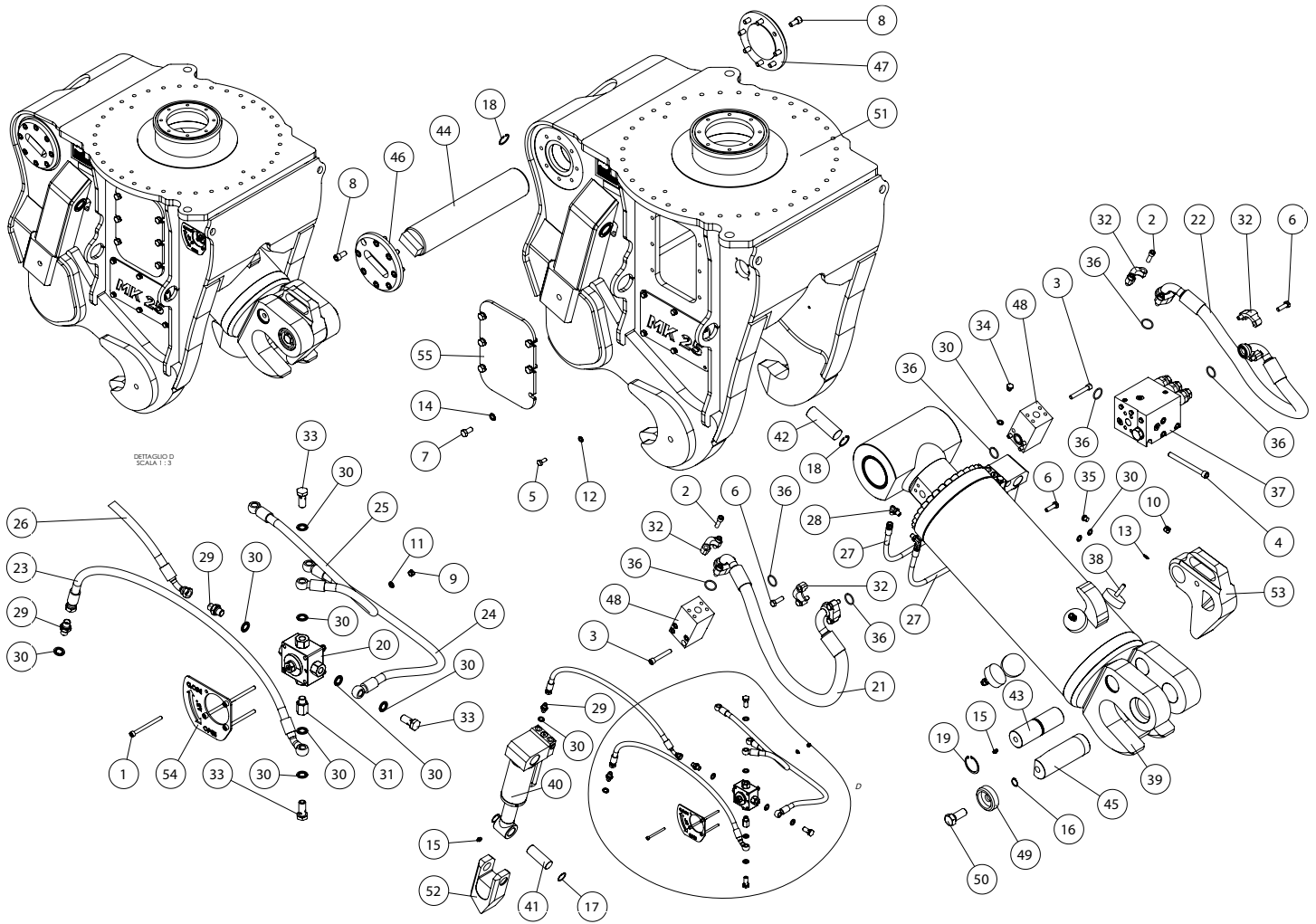

MRX250 Body Parts Illustration			
Item	Qty	Description	Part Number
1	4	SOCKET HEAD CAPSCREW	518387
2	8	SOCKET HEAD CAPSCREW	518186
3	8	SOCKET HEAD CAPSCREW	518187
4	4	SOCKET HEAD CAPSCREW	518188
5	12	HEX HEAD CAPSCREW	518192
6	8	HEX HEAD CAPSCREW	518193
7	12	HEX HEAD CAPSCREW	518195
8	16	HEX NUT W/NYLOCK	518198
9	4	HEX NUT W/NYLOCK	518350
10	4	HEX NUT W/NYLOCK	518351
11	4	FLAT WASHER	518352
12	12	FLAT WASHER	518353
13	4	FLAT WASHER	518354

MRX250 Body Parts Illustration

Item	Qty	Description	Part Number
14	12	FLAT WASHER	518355
15	3	GREASE ZERK	518203
16	1	C CLIP	518357
17	4	C CLIP	518388
18	4	C CLIP	518389
19	2	C CLIP	518390
20	1	VALVE SWITCH	518360
21	1	HOSE ASSEMBLY	518245
22	1	HOSE ASSEMBLY	518246
23	1	HYDRAULIC HOSE	518391
24	1	HYDRAULIC HOSE	518392
25	1	HYDRAULIC HOSE	518393
26	1	HYDRAULIC HOSE	518394
27	2	HYDRAULIC HOSE	518395
28	4	HOSE ADAPTOR	518367
29	3	HOSE ADAPTOR	518368
30	15	FLAT WASHER	518308
31	1	EXTENSION ADAPTOR	518369
32	8	SPLIT FLANGE HALF	518204
33	4	HYDRAULIC ADAPTOR PLUG	518370
34	2	HYDRAULIC ADAPTOR PLUG	518310
35	1	HYDRAULIC ADAPTOR PLUG	518397
36	8	O RING SEAL	518205
37	1	MACHINING MANIFOLD	518208
38	4	DAMPENER	518374
39	1	CYLINDER ASSEMBLY	518398
40	2	CYLINDER ASSEMBLY	518399
41	2	PIN MACHINING	518400
42	2	PIN MACHINING	518401
43	1	PIN MACHINING	518402
44	1	MACHINING PIN	518213
45	1	PIN MACHINING	518403
46	1	PIN RETAINER	518216
47	1	PIN RETAINER	518219
48	2	MANIFOLD MACHINING	518220
49	1	FLAT WASHER	518381
50	1	HEX HEAD CAPSCREW	518382
51	1	MRX250 STICK	518404
52	2	CUTTING EDGE	518405
53	1	CYLINDER RETAINER	518406
54	1	OPEN CLOSE PLATE	518386
55	2	COVER PLATE	518226

ROTATION

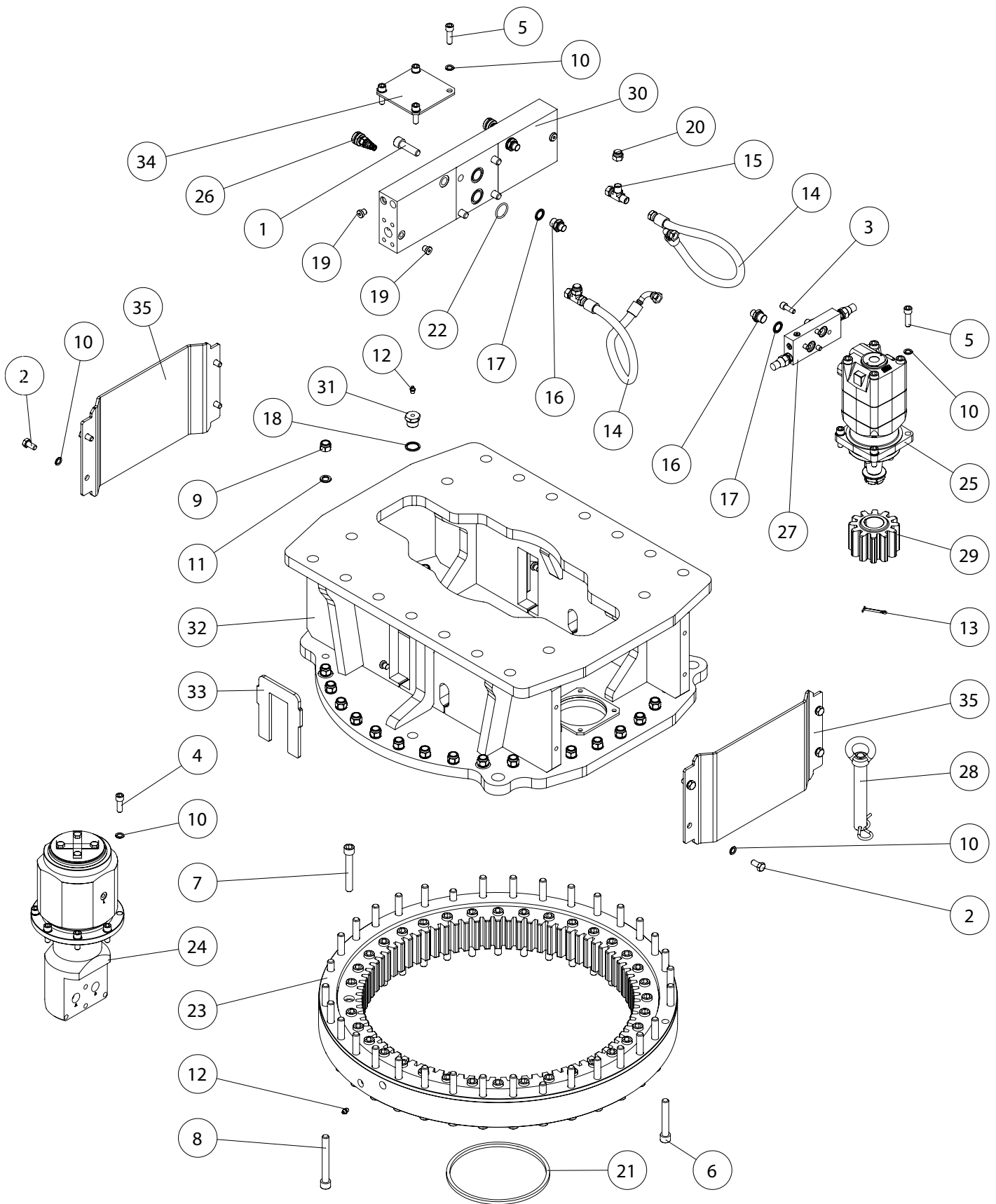

MRX250 Rotation Parts Illustration

Item	Qty	Description	Part Number
1	4	SOCKET HEAD CAPSCREW	518705
2	8	HEX HEAD CAPSCREW	518706
3	4	SOCKET HEAD CAPSCREW	518707
4	8	SOCKET HEAD CAPSCREW	518708
5	8	SOCKET HEAD CAPSCREW	518709
6	4	SOCKET HEAD CAPSCREW	518711
7	36	SOCKET HEAD CAPSCREW	518712
8	32	SOCKET HEAD CAPSCREW	518713
9	32	HEX NUT W/NYLOCK	518199
10	24	FLAT WASHER	518354
11	32	FLAT WASHER	518714
12	6	GREASE ZERK	518203
13	1	COTTER (SPLIT) PIN	518715
14	2	HOSE ASSEMBLY	518716
15	2	HOSE ADAPTOR	518717
16	4	HOSE ADAPTOR	518718
17	4	FLAT WASHER	518720
18	2	FLAT WASHER	518721
19	7	HYDRAULIC ADAPTOR PLUG	518397
20	2	HYDRAULIC ADAPTOR PLUG	518722
21	1	8x8 mm GASKET	518724
22	2	O RING SEAL	518205
23	1	TURN TABLE BEARING	518725
24	1	HYDRAULIC DISTRIBUTOR	518726
25	1	HYDRAULIC MOTOR	518727
26	2	HYDRAULIC ADAPTOR	518728
27	1	MANIFOLD MACHINING	518730
28	1	HITCH PIN	518731
29	1	PINION GEAR	518732
30	1	MANIFOLD MACHINING	518733
31	2	HYDRAULIC ADAPTOR PLUG	518734
32	1	UPPERHEAD WELDMENT MACHINING	518736
33	2	SIDE PLATE	518737
34	1	COVER PLATE	518738
35	2	FORMED COVER PLATE	518740

CRACKER JAW

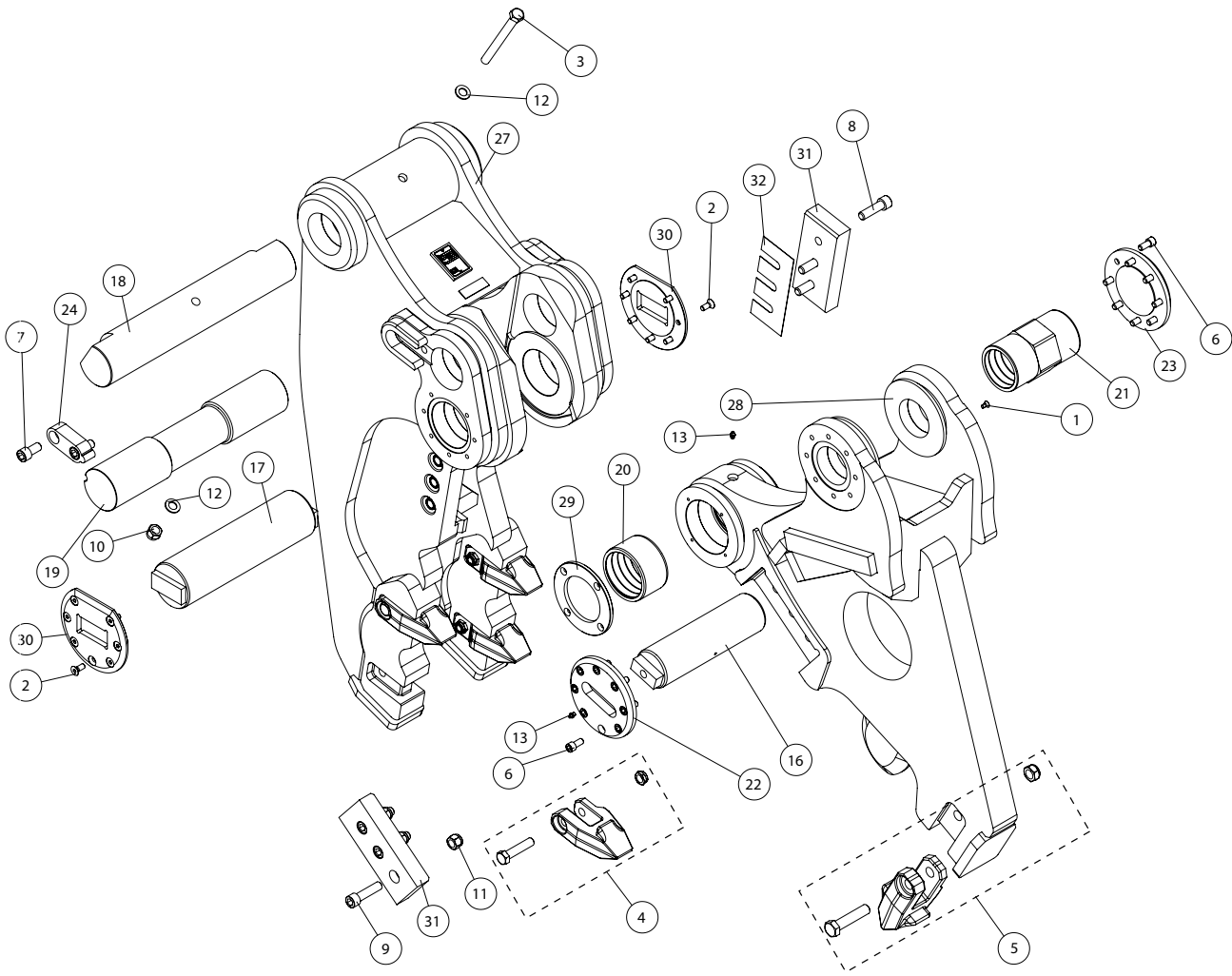

MRX250 Cracker Jaw Parts Illustration

Item	Qty	Description	Part Number
1	8	SOCKET HEAD CAPSCREW	518431
2	14	SOCKET HEAD CAPSCREW	518416
3	1	HEX HEAD CAPSCREW	518432
4	4	CUTTING EDGE KIT	518171
5	1	CUTTING EDGE KIT	518170
6	16	HEX NUT W/NYLOCK	518198
7	4	HEX HEAD CAPSCREW	518433
8	3	SOCKET HEAD CAPSCREW	See "MRX Blade Kits" on page 53
9	3	SOCKET HEAD CAPSCREW	See "MRX Blade Kits" on page 53
10	1	HEX NUT W/NYLOCK	518435
11	6	HEX NUT W/NYLOCK	See "MRX Blade Kits" on page 53
12	2	FLAT WASHER	518436
13	2	GREASE ZERK	518203
16	1	PIN MACHINING	518593
17	1	PIN MACHINING	518594
18	1	PIN MACHINING	518595
19	1	PIN MACHINING	518596
20	2	BEARING MACHINING	518251
21	1	BEARING MACHINING	518597
22	1	PIN RETAINER	518216
23	1	PIN RETAINER	518219
24	2	PIN RETAINER	518426
27	1	UPPER WELDMENT MACHINING	518630
28	1	LOWER WELDMENT MACHINING	518631
29	2	SPACER SHIM	518600
30	2	SPACER SHIM	518602
31	2	BLADE MACHINING	See "MRX Blade Kits" on page 53
32	1	BLADE SHIM	See "MRX Blade Kits" on page 53

PULVERIZER JAW

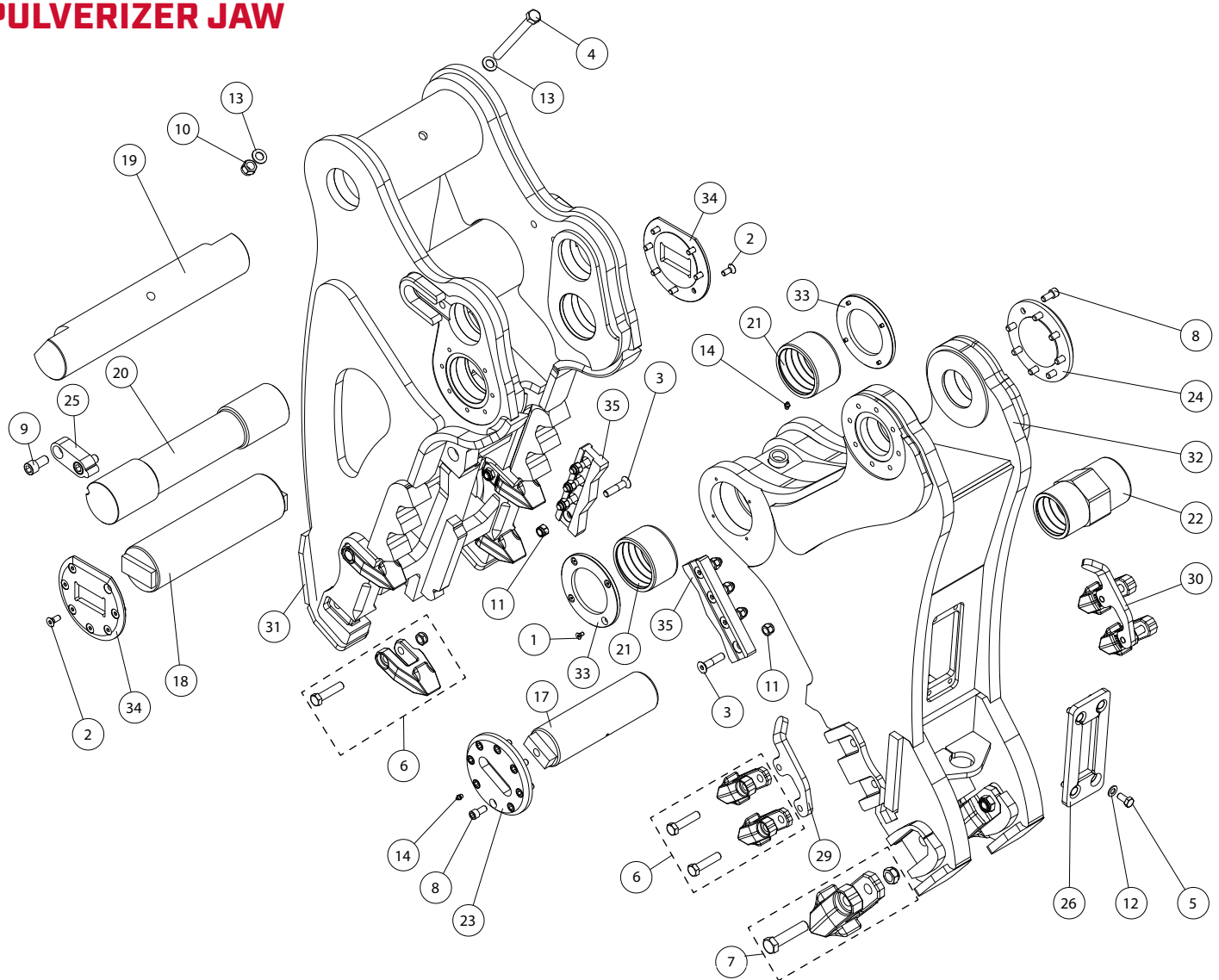

MRX250 Pulverizer Jaw Parts Illustration			
Item	Qty	Description	Part Number
1	8	SOCKET HEAD CAPSCREW	518431
2	14	SOCKET HEAD CAPSCREW	518416
3	8	HEX HEAD CAPSCREW	See "MRX Blade Kits" on page 53
4	1	HEX HEAD CAPSCREW	518432
5	4	HEX HEAD CAPSCREW	518195
6	10	CUTTING EDGE KIT	518169
7	4	CUTTING EDGE KIT	518170
8	16	HEX NUT W/NYLOCK	518198
9	4	HEX HEAD CAPSCREW	518433
10	1	HEX NUT W/NYLOCK	518435
11	8	HEX NUT W/NYLOCK	See "MRX Blade Kits" on page 53

MRX250 Pulverizer Jaw Parts Illustration

Item	Qty	Description	Part Number
12	4	FLAT WASHER	518202
13	2	FLAT WASHER	518436
14	2	GREASE ZERK	518203
17	1	PIN MACHINING	518593
18	1	PIN MACHINING	518594
19	1	PIN MACHINING	518595
20	1	PIN MACHINING	518654
21	2	BEARING MACHINING	518251
22	1	BEARING MACHINING	518597
23	1	PIN RETAINER	518216
24	1	PIN RETAINER	518219
25	2	PIN RETAINER	518426
26	1	COVER PLATE	518646
29	1	CUTTING EDGE	518649
30	1	CUTTING EDGE	518650
31	1	UPPER WELDMENT MACHINING	518655
32	1	LOWER WELDMENT MACHINING	518657
33	2	SPACER SHIM	518600
34	2	SPACER SHIM	518602
35	2	BLADE MACHINING	See "MRX Blade Kits" on page 53

SHEAR JAW

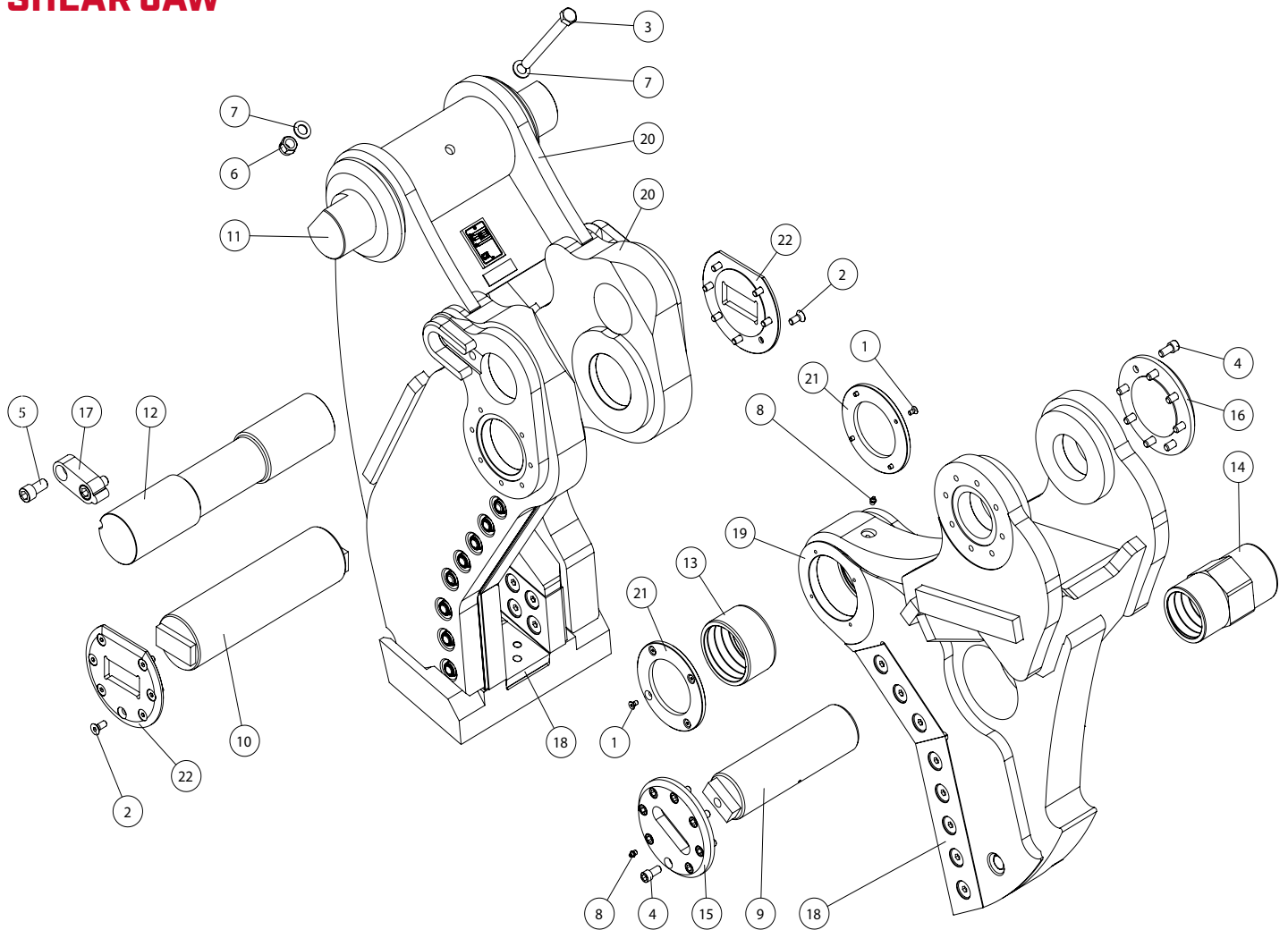

MRX250 Shear Jaw Parts Illustration			
Item	Qty	Description	Part Number
1	8	SOCKET HEAD CAPSCREW	518431
2	14	SOCKET HEAD CAPSCREW	518416
3	1	HEX HEAD CAPSCREW	518432
4	16	HEX NUT W/NYLOCK	518198
5	4	HEX HEAD CAPSCREW	518433
6	1	HEX NUT W/NYLOCK	518435
7	2	FLAT WASHER	518436
8	2	GREASE ZERK	518203
9	1	PIN MACHINING	518593
10	1	PIN MACHINING	518594
11	1	PIN MACHINING	518595
12	1	PIN MACHINING	518596
13	2	BEARING MACHINING	518251

MRX250 Shear Jaw Parts Illustration			
Item	Qty	Description	Part Number
14	1	BEARING MACHINING	518597
15	1	PIN RETAINER	518216
16	1	PIN RETAINER	518219
17	2	PIN RETAINER	518426
18	1	MRX250 BLADE KIT	518175
19	1	UPPER WELDMENT MACHINING	518598
20	1	LOWER WELDMENT MACHINING	518599
21	2	SPACER SHIM	518600
22	2	SPACER SHIM	518602

SHEAR JAW FULL BLADE KIT

Full blade kits contain all the parts of the Cutting Blade Kit and the Tip Blade Kit. Use part number 518175 for a MRX250 Shear Jaw Full Blade Kit.

Cutting Blade Kit - P/N 232548

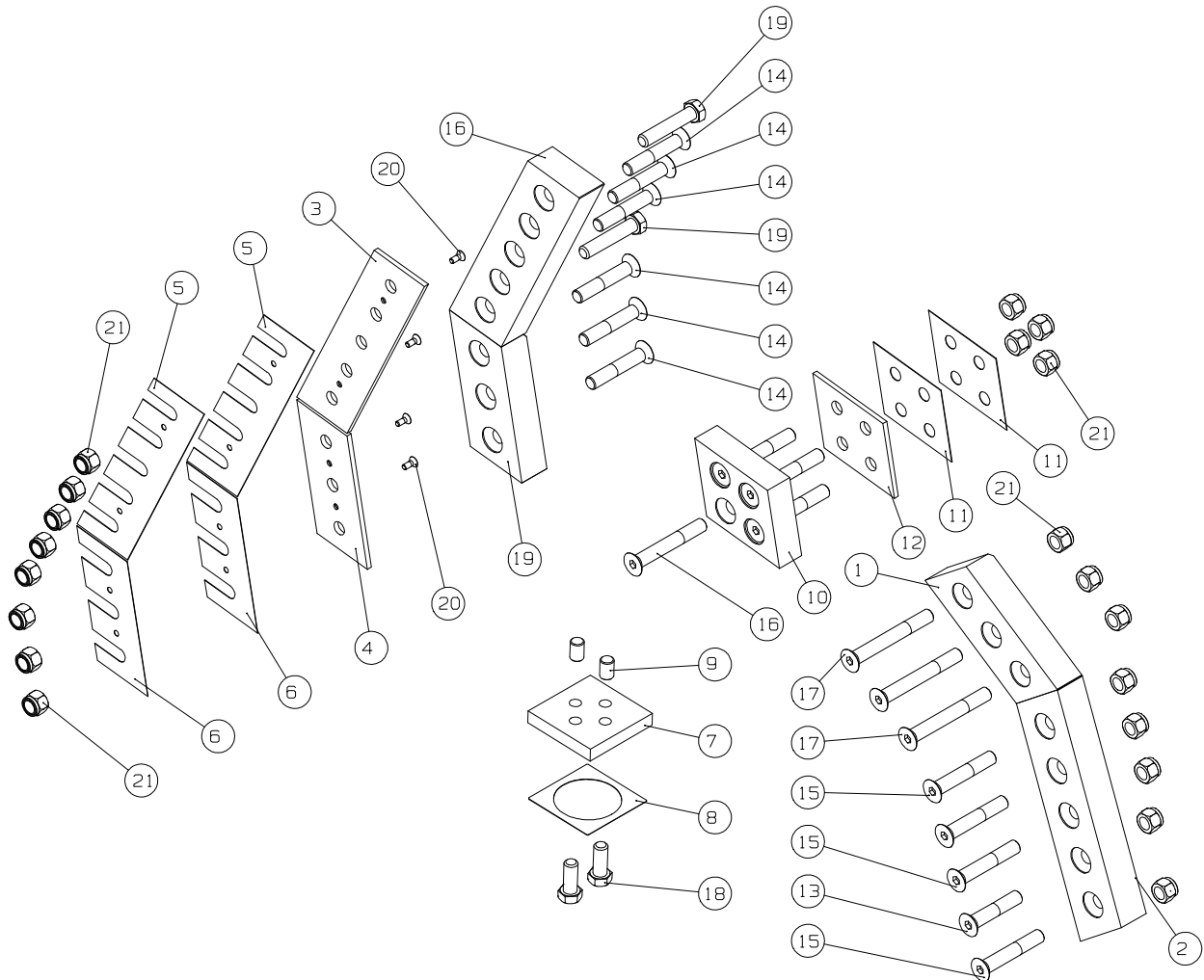

MRX250 Shear Jaw Cutting Blade Kit Parts Illustration			
Item	Qty	Description	Part Number
1	2	BLADE MACHINING	518698
2	2	BLADE MACHINING	518695
3	1	SPACER	518690
4	1	SPACER	518693
5	2	SHIM	518702
6	2	SHIM	518703
7	1	CROSS BLADE MACHINING	518694
8	1	SHIM	518699
9	2	DOWEL PIN	518671
10	1	GUIDE BLADE MACHINING	518697

MRX250 Shear Jaw Cutting Blade Kit Parts Illustration			
Item	Qty	Description	Part Number
11	2	SHIM	518700
12	1	SPACER	518691
13	1	CAPSCREW	501524
14	6	CAPSCREW	502046
15	4	CAPSCREW	501525
16	4	CAPSCREW	518667
17	3	CAPSCREW	502615
18	2	CAPSCREW	502358
19	2	CAPSCREW	501516
20	4	CAPSCREW	518670
21	20	NUT	518200

Tip Blade Kit - P/N 232549

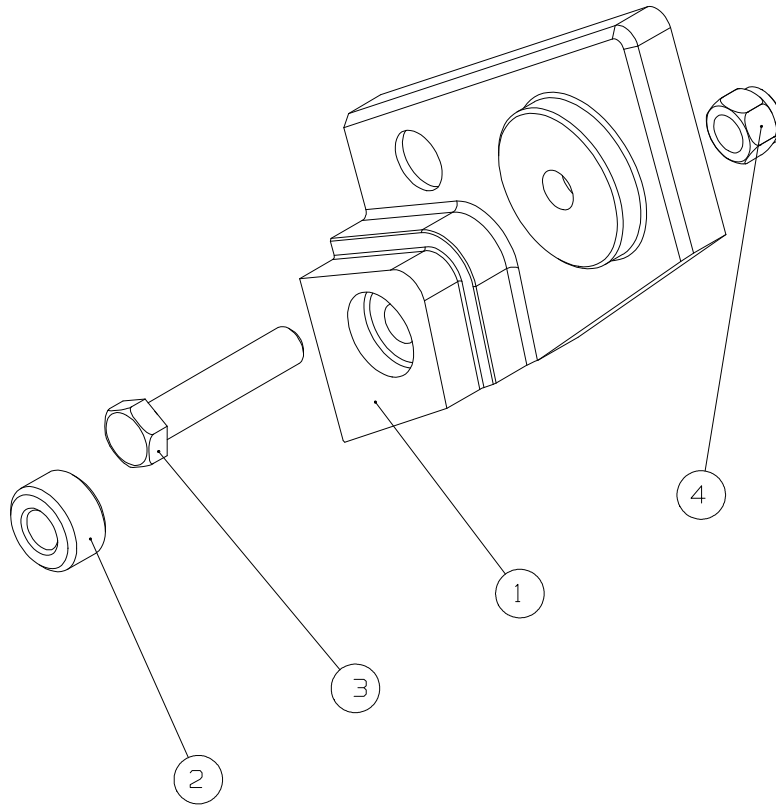

MRX250 Shear Jaw Tip Blade Kit Parts Illustration			
Item	Qty	Description	Part Number
1	1	BLADE MACHINING	518696
2	1	PIN	518672
3	1	CAPSCREW	501516
4	1	NUT	518200

MRX350

BODY

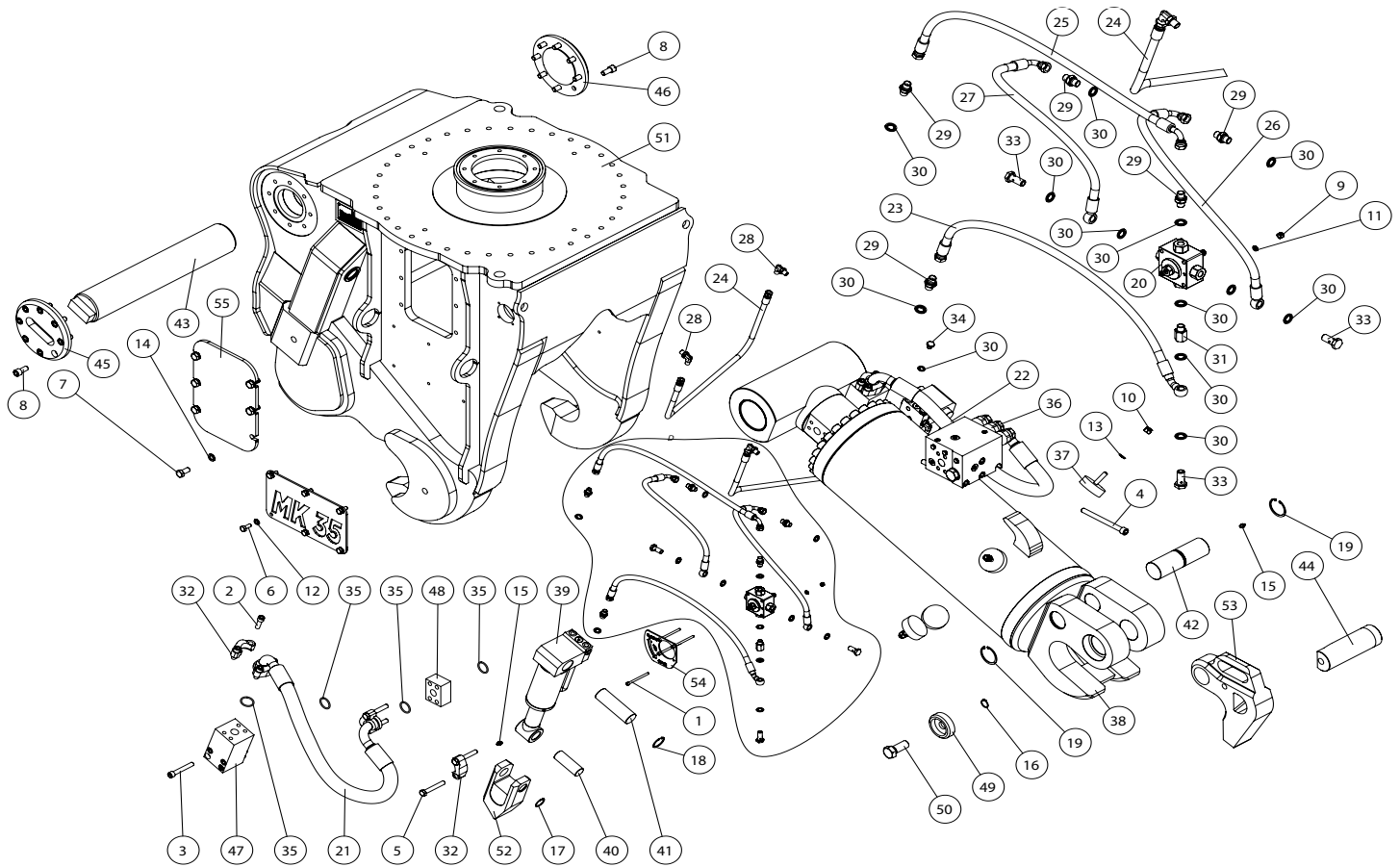

MRX350 Body Parts Illustration			
Item	Qty	Description	Part Number
1	4	SOCKET HEAD CAPSCREW	518407
2	8	SOCKET HEAD CAPSCREW	518186
3	8	SOCKET HEAD CAPSCREW	518187
4	4	SOCKET HEAD CAPSCREW	518188
5	8	HEX HEAD CAPSCREW	518239
6	12	HEX HEAD CAPSCREW	518192
7	12	HEX HEAD CAPSCREW	518195
8	16	HEX NUT W/NYLOCK	518198
9	4	HEX NUT W/NYLOCK	518350
10	4	HEX NUT W/NYLOCK	518351
11	4	FLAT WASHER	518352
12	12	FLAT WASHER	518353
13	4	FLAT WASHER	518354
14	12	FLAT WASHER	518355
15	3	GREASE ZERK	518203
16	1	C CLIP	518357
17	4	C CLIP	518388

MRX350 Body Parts Illustration

Item	Qty	Description	Part Number
18	4	C CLIP	518389
19	2	C CLIP	518390
20	1	VALVE SWITCH	518360
21	1	HOSE ASSEMBLY	518245
22	1	HOSE ASSEMBLY	518246
23	1	HYDRAULIC HOSE	518391
24	2	HYDRAULIC HOSE	518408
25	1	HYDRAULIC HOSE	518409
26	1	HYDRAULIC HOSE	518410
27	1	HYDRAULIC HOSE	518411
28	4	HOSE ADAPTOR	518367
29	5	HOSE ADAPTOR	518368
30	14	FLAT WASHER	518308
31	1	EXTENSION ADAPTOR	518369
32	8	SPLIT FLANGE HALF	518204
33	3	HYDRAULIC ADAPTOR PLUG	518370
34	2	1/4 INCH PLUG	518310
35	10	O RING SEAL	518205
36	1	MACHINING MANIFOLD	518208
37	4	DAMPENER	518374
38	1	CYLINDER ASSEMBLY	518412
39	2	CYLINDER ASSEMBLY	518399
40	2	PIN MACHINING	518400
41	2	PIN MACHINING	518401
42	1	PIN MACHINING	518402
43	1	PIN MACHINING	518269
44	1	PIN MACHINING	518403
45	1	PIN RETAINER	518216
46	1	PIN RETAINER	518219
47	2	MANIFOLD MACHINING	518220
48	2	MANIFOLD MACHINING	518256
49	1	FLAT WASHER	518381
50	1	HEX HEAD CAPSCREW	518382
51	1	MRX350 STICK	518413
52	2	CUTTING EDGE	518405
53	1	CYLINDER RETAINER	518414
54	1	OPEN CLOSE PLATE	518386
55	2	COVER PLATE	518226

ROTATION

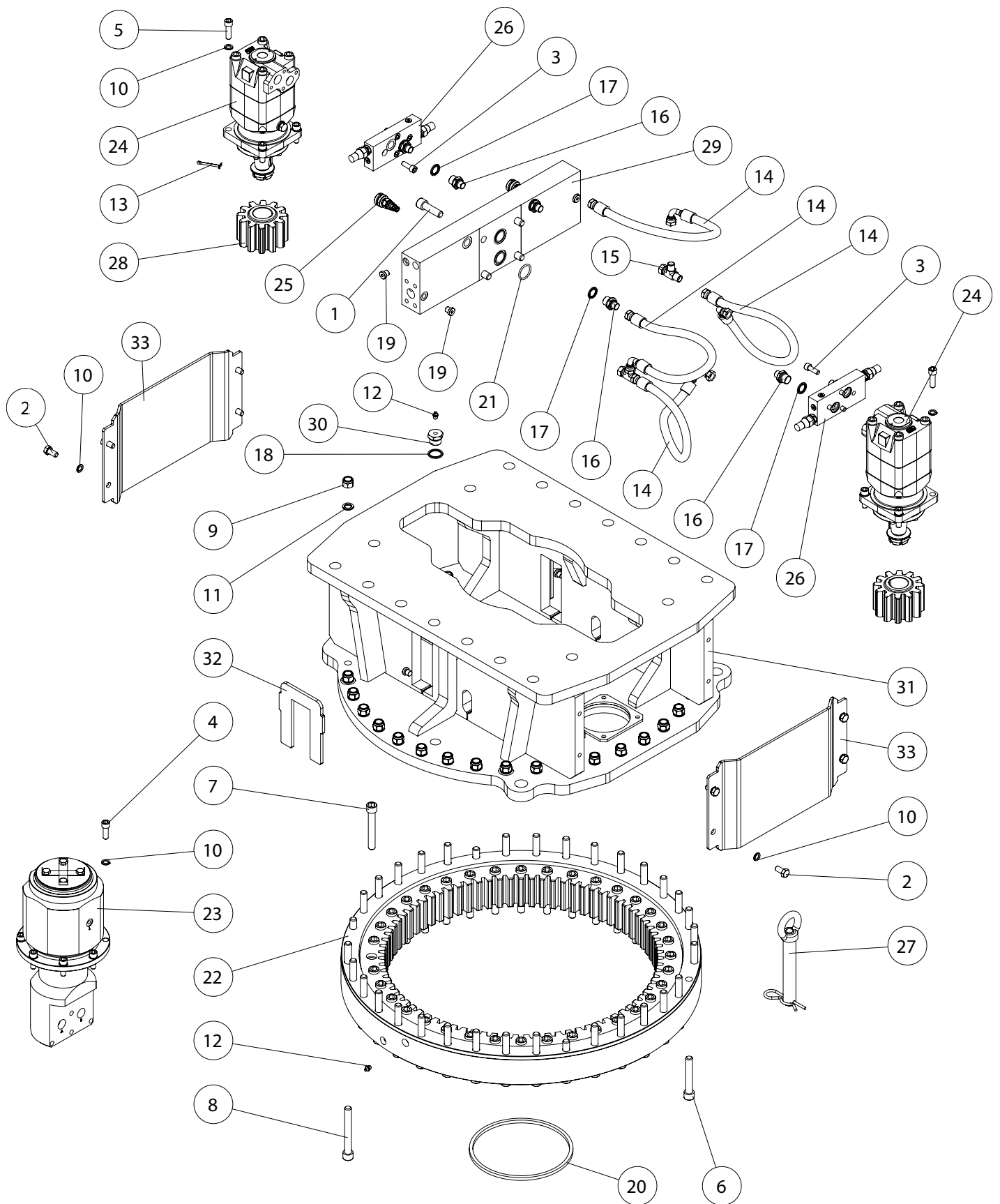

MRX350 Rotation Parts Illustration

Item	Qty	Description	Part Number
1	4	SOCKET HEAD CAPSCREW	518705
2	8	HEX HEAD CAPSCREW	518706
3	8	SOCKET HEAD CAPSCREW	518707
4	8	SOCKET HEAD CAPSCREW	518709
5	8	SOCKET HEAD CAPSCREW	518709
6	4	SOCKET HEAD CAPSCREW	518711
7	36	SOCKET HEAD CAPSCREW	518712
8	32	SOCKET HEAD CAPSCREW	518713
9	32	HEX NUT W/NYLOCK	518199
10	24	FLAT WASHER	518354
11	32	FLAT WASHER	518714
12	6	GREASE ZERK	518203
13	2	COTTER (SPLIT) PIN	518715
14	4	HOSE ASSEMBLY	518716
15	2	HOSE ADAPTOR	518717
16	6	HOSE ADAPTOR	518718
17	6	FLAT WASHER	518720
18	2	FLAT WASHER	518721
19	7	HYDRAULIC ADAPTOR PLUG	518397
20	1	8x8 mm GASKET	518724
21	2	O RING SEAL	518205
22	1	TURN TABLE BEARING	518725
23	1	HYDRAULIC DISTRIBUTOR	518726
24	2	HYDRAULIC MOTOR	518727
25	2	HYDRAULIC ADAPTOR	518728
26	2	MANIFOLD MACHINING	518730
27	1	HITCH PIN	518731
28	2	PINION GEAR	518732
29	1	MANIFOLD MACHINING	518733
30	2	HYDRAULIC ADAPTOR PLUG	518734
31	1	UPPERHEAD WELDMENT MACHINING	518736
32	2	SIDE PLATE	518737
33	2	FORMED COVER PLATE	518740

CRACKER JAW

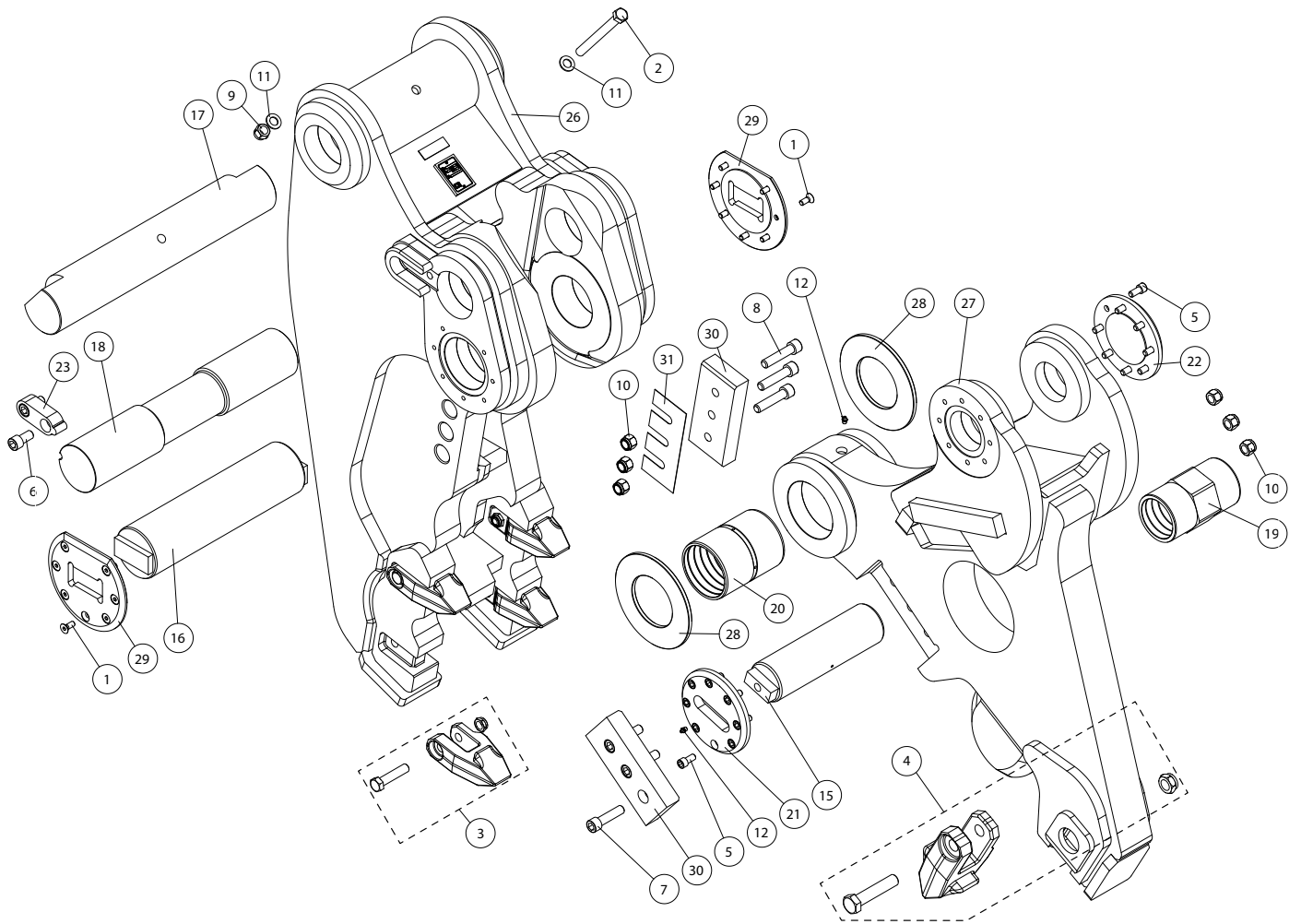

MRX350 Cracker Jaw Parts Illustration

Item	Qty	Description	Part Number
1	14	SOCKET HEAD CAPSCREW	See "MRX Wear Kits" on page 53
2	1	HEX HEAD CAPSCREW	518432
3	4	CUTTING EDGE KIT	518171
4	1	CUTTING EDGE KIT	518172
5	16	HEX NUT W/NYLOCK	518198
6	1	HEX HEAD CAPSCREW	518433
7	3	SOCKET HEAD CAPSCREW	See "MRX Blade Kits" on page 53
8	3	SOCKET HEAD CAPSCREW	See "MRX Blade Kits" on page 53
9	1	HEX NUT W/NYLOCK	See "MRX Blade Kits" on page 53
10	6	HEX NUT W/NYLOCK	See "MRX Blade Kits" on page 53
11	2	FLAT WASHER	518436
12	2	GREASE ZERK	518203
15	1	PIN MACHINING	518593
16	1	PIN MACHINING	518603
17	1	PIN MACHINING	518604
18	1	PIN MACHINING	518605
19	1	BEARING MACHINING	518597
20	1	BEARING MACHINING	518637
21	1	PIN RETAINER	518216
22	1	PIN RETAINER	518219
23	2	PIN RETAINER	518426
26	1	LOWER WELDMENT MACHINING	518640
27	1	UPPER WELDMENT MACHINING	518641
28	2	SPACER SHIM	518609
29	2	SPACER SHIM	518611
30	2	BLADE MACHINING	See "MRX Blade Kits" on page 53
31	1	BLADE SHIM	See "MRX Blade Kits" on page 53

PULVERIZER JAW

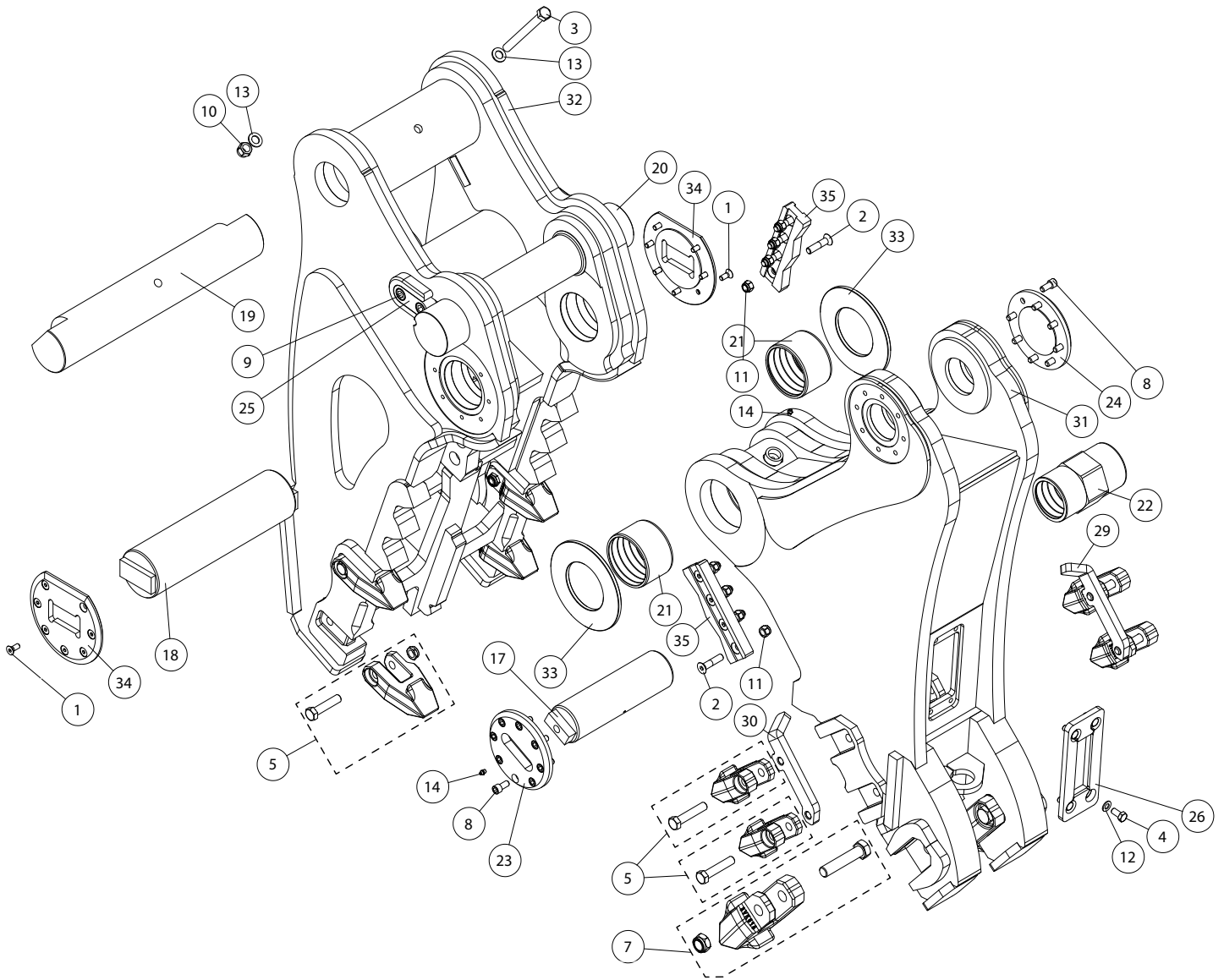

MRX350 Pulverizer Jaw Parts Illustration			
Item	Qty	Description	Part Number
1	14	SOCKET HEAD CAPSCREW	518416
2	8	HEX HEAD CAPSCREW	See "MRX Blade Kits" on page 53
3	1	HEX HEAD CAPSCREW	518432
4	4	HEX HEAD CAPSCREW	518195
5	4	CUTTING EDGE KIT	518171
7	2	CUTTING EDGE KIT	518172
8	16	HEX NUT W/NYLOCK	518198
9	4	HEX HEAD CAPSCREW	518433

MRX350 Pulverizer Jaw Parts Illustration

Item	Qty	Description	Part Number
10	1	HEX NUT W/NYLOCK	518435
11	8	HEX NUT W/NYLOCK	See "MRX Blade Kits" on page 53
12	4	FLAT WASHER	518202
13	2	FLAT WASHER	518436
14	2	GREASE ZERK	518203
17	1	PIN MACHINING	518593
18	1	PIN MACHINING	518603
19	1	PIN MACHINING	518604
20	1	PIN MACHINING	518659
21	2	BEARING MACHINING	518660
22	1	BEARING MACHINING	518597
23	1	PIN RETAINER	518216
24	1	PIN RETAINER	518219
25	2	PIN RETAINER	518426
26	1	COVER PLATE	518646
29	1	CUTTING EDGE	518661
30	1	CUTTING EDGE	518662
31	1	UPPER WELDMENT MACHINING	518663
32	1	LOWER WELDMENT MACHINING	518664
33	2	SPACER SHIM	518609
34	2	SPACER SHIM	518611
35	2	BLADE MACHINING	See "MRX Blade Kits" on page 53

SHEAR JAW

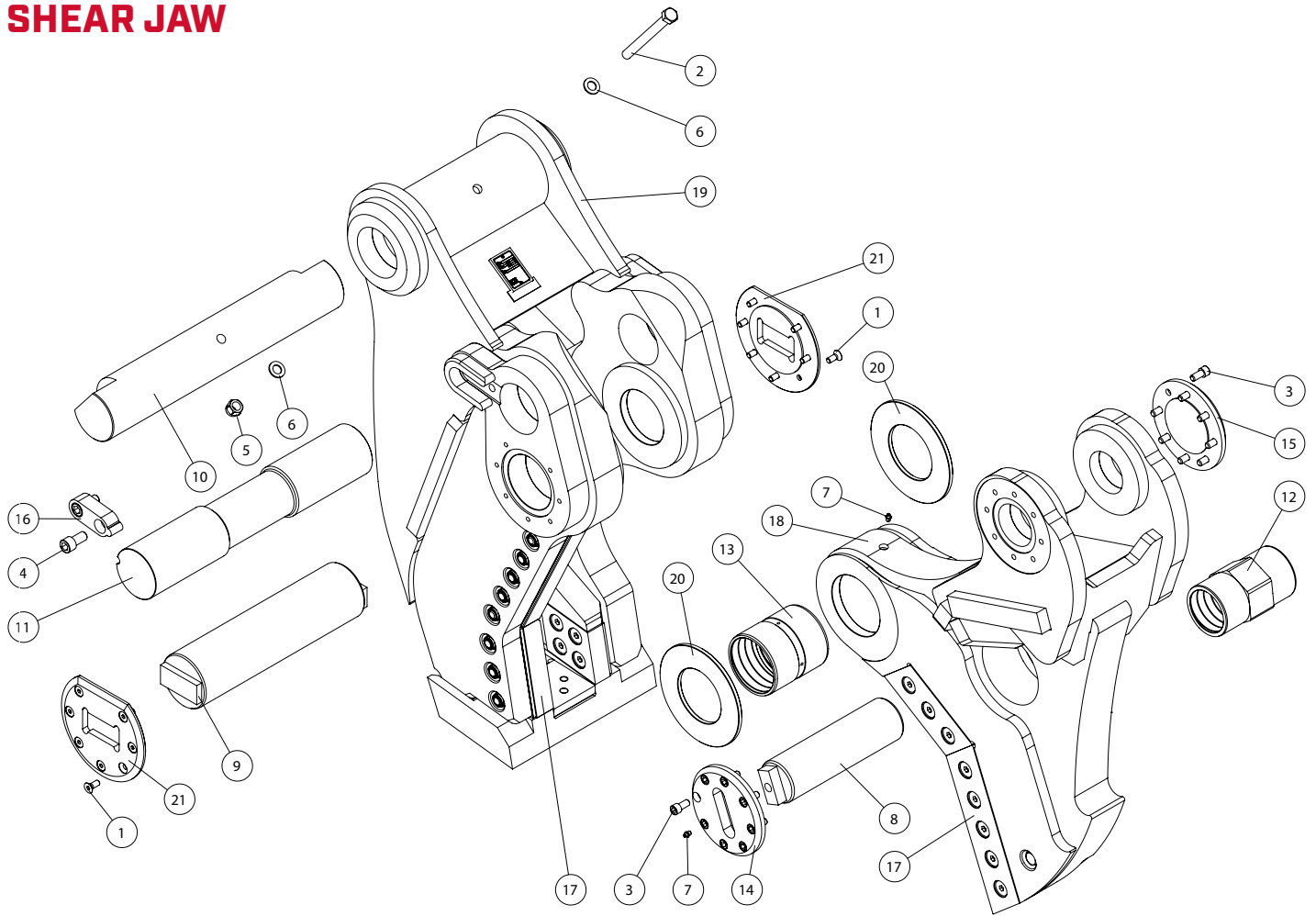

MRX350 Shear Jaw Parts Illustration			
Item	Qty	Description	Part Number
1	14	SOCKET HEAD CAPSCREW	518416
2	1	HEX HEAD CAPSCREW	518432
3	16	HEX NUT W/NYLOCK	518198
4	4	HEX HEAD CAPSCREW	518433
5	1	HEX NUT W/NYLOCK	518435
6	2	FLAT WASHER	518436
7	2	GREASE ZERK	518203
8	1	PIN MACHINING	518593
9	1	PIN MACHINING	518603
10	1	PIN MACHINING	518604
11	1	PIN MACHINING	518605
12	1	BEARING MACHINING	518597
13	1	BEARING MACHINING	518606
14	1	PIN RETAINER	518216
15	1	PIN RETAINER	518219

MRX350 Shear Jaw Parts Illustration			
Item	Qty	Description	Part Number
16	2	PIN RETAINER	518426
17	1	BLADE KIT	518176
18	1	UPPER WELDMENT MACHINING	518607
19	1	LOWER WELDMENT MACHINING	518608
20	2	SPACER SHIM	518609
21	2	SPACER SHIM	518611

SHEAR JAW FULL BLADE KIT

Full blade kits contain all the parts of the Cutting Blade Kit and the Tip Blade Kit. Use part number 518176 for a MRX350 Shear Jaw Full Blade Kit.

Cutting Blade Kit - P/N 232548

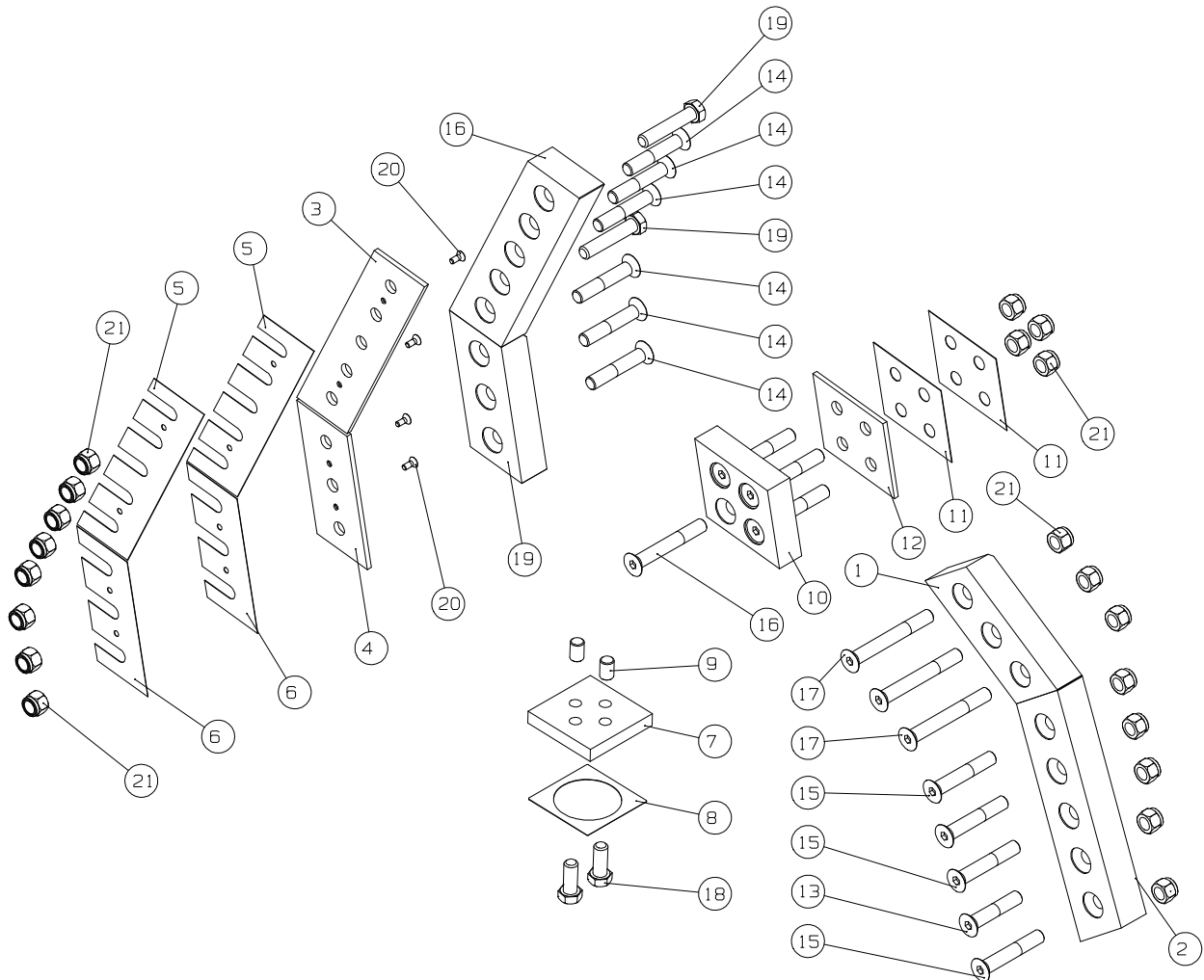

MRX350 Shear Jaw Cutting Blade Kit Parts Illustration			
Item	Qty	Description	Part Number
1	2	BLADE MACHINING	518698
2	2	BLADE MACHINING	518695
3	1	SPACER	518690
4	1	SPACER	518693
5	2	SHIM	518702
6	2	SHIM	518703
7	1	CROSS BLADE MACHINING	518694
8	1	SHIM	518699
9	2	DOWEL PIN	518671
10	1	GUIDE BLADE MACHINING	518697

MRX350 Shear Jaw Cutting Blade Kit Parts Illustration			
Item	Qty	Description	Part Number
11	2	SHIM	518700
12	1	SPACER	518691
13	1	CAPSCREW	501524
14	6	CAPSCREW	502046
15	4	CAPSCREW	501525
16	4	CAPSCREW	518667
17	3	CAPSCREW	502615
18	2	CAPSCREW	502358
19	2	CAPSCREW	501516
20	4	CAPSCREW	518670
21	20	NUT	518200

Tip Blade Kit - P/N 232549

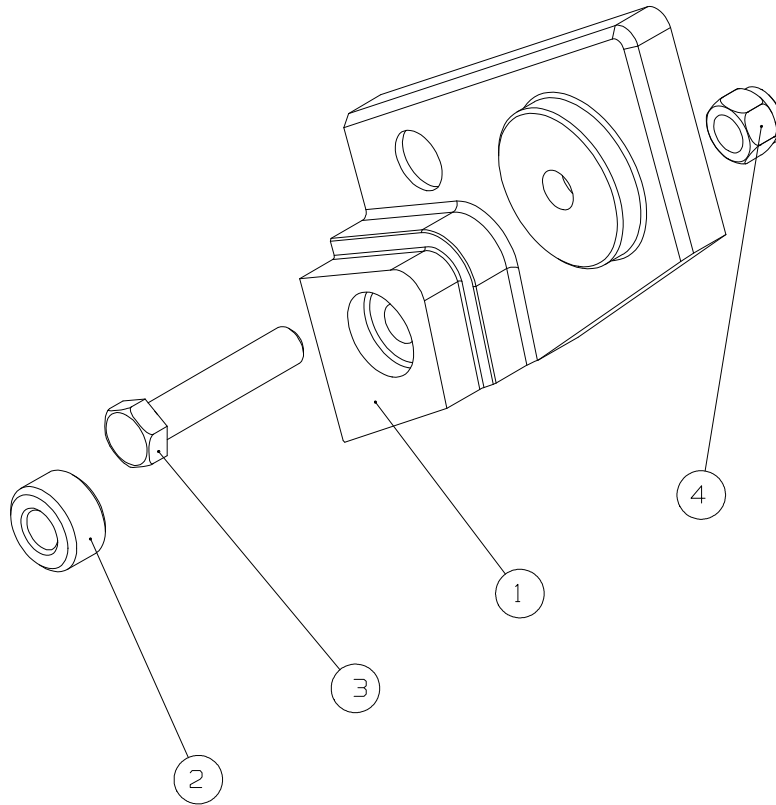

MRX350 Shear Jaw Tip Blade Kit Parts Illustration			
Item	Qty	Description	Part Number
1	1	BLADE MACHINING	518696
2	1	PIN	518672
3	1	CAPSCREW	501516
4	1	NUT	518200

HYDRAULIC SCHEMATIC

ROTATION HYDRAULIC DIAGRAM

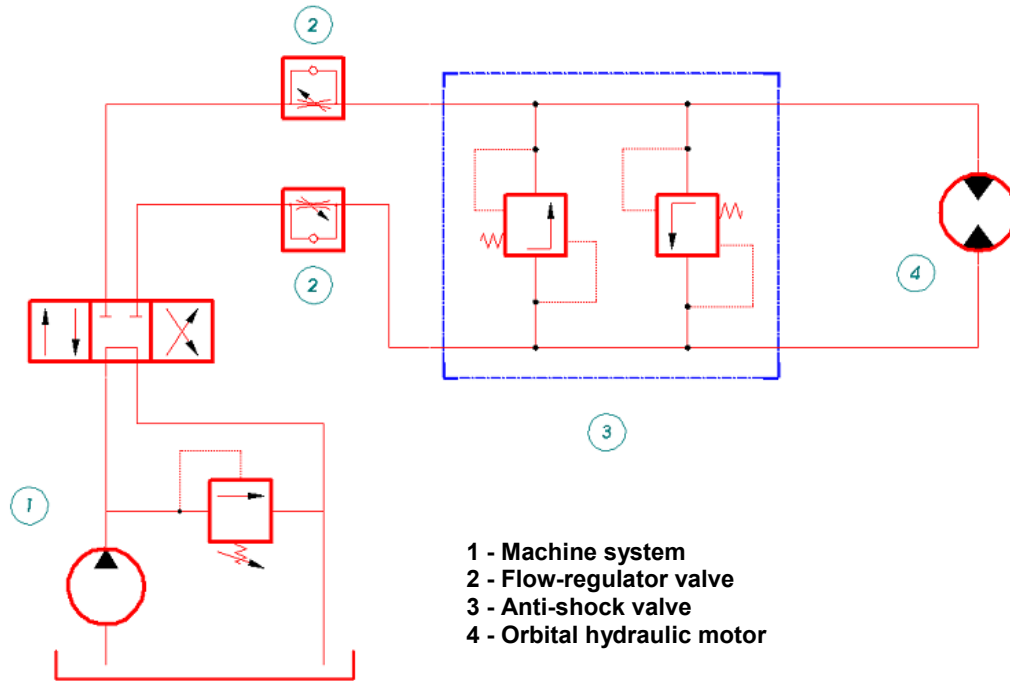

HYDRAULIC POWER DIAGRAM

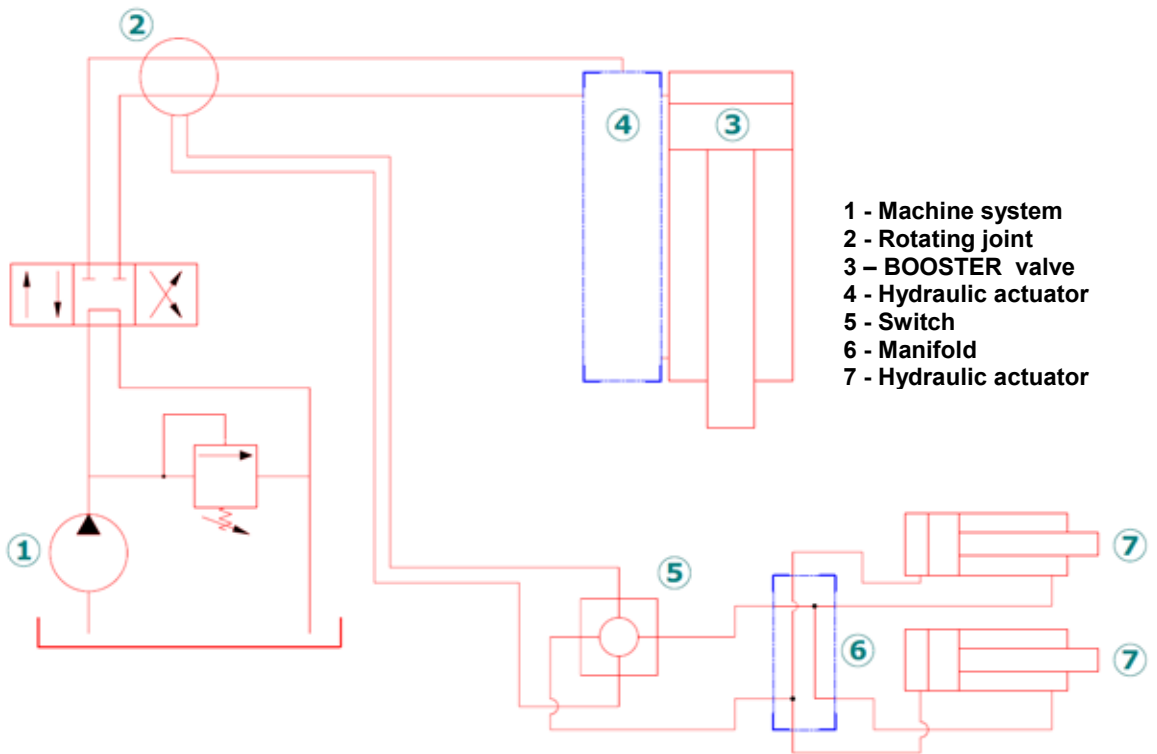

WEAR PART KITS

FULL BLADE KITS

MRX Blade Kits			
Model	Jaw Set	Description	Part Number
MRX150	Shear	Full blade kit includes all blades, bolts [etc] needed for a blade change.	519383
	Concrete Pulverizer		519378
	Concrete Cracking		519381
MRX200	Shear	Full blade kit includes all blades, bolts [etc] needed for a blade change.	518174
	Concrete Pulverizer		518782
	Concrete Cracking		518173
MRX250	Shear	Full blade kit includes all blades, bolts [etc] needed for a blade change.	518175
	Concrete Pulverizer		518782
	Concrete Cracking		518783
MRX350	Shear	Full blade kit includes all blades, bolts [etc] needed for a blade change.	518176
	Concrete Pulverizer		518782
	Concrete Cracking		518784

CUTTING BLADE & TIP KITS (SHEAR JAWS ONLY)

MRX Blade Kits			
Model	Jaw Set	Description	Part Number
MRX200	Cutting Blade Kit	Kit includes all blades, bolts [etc] needed to change the cutting blades.	232546
	Tip Blade Kit	Kit includes all the blades, bolts [etc] needed to change the tip blade.	232547
MRX250	Cutting Blade Kit	Kit includes all blades, bolts [etc] needed to change the cutting blades.	232548
	Tip Blade Kit	Kit includes all the blades, bolts [etc] needed to change the tip blade.	232549
MRX350	Cutting Blade Kit	Kit includes all blades, bolts [etc] needed to change the cutting blades.	232548
	Tip Blade Kit	Kit includes all the blades, bolts [etc] needed to change the tip blade.	232549

WEAR KITS

MRX Wear Kits			
Model	Jaw Set	Description	Part Number
MRX150	Shear	Full wear kit includes all teeth, bolts [etc] needed to replace the wear items.	-
	Concrete Pulverizer		519688
	Concrete Cracking		519690

MRX Wear Kits

Model	Jaw Set	Description	Part Number
MRX200	Shear	Full wear kit includes all teeth, bolts [etc] needed to replace the wear items.	-
	Concrete Pulverizer		518165
	Concrete Cracking		518168
MRX250	Shear	Full wear kit includes all teeth, bolts [etc] needed to replace the wear items.	-
	Concrete Pulverizer		518166
	Concrete Cracking		518180
MRX350	Shear	Full wear kit includes all teeth, bolts [etc] needed to replace the wear items.	-
	Concrete Pulverizer		518167
	Concrete Cracking		518181

LABOUNTY®

Additional copies of this manual are available by contacting your dealer or the LaBounty parts department, and requesting a CE Operation & Maintenance manual. You must include the attachment model number and serial number.