

STANLEY

Original instructions

ENG

5/19

Stanley MB/XP4035

HYDRAULIC BREAKER Parts manual



Part Number: **PMMB/XP4035XENG.519**

Contents

Housing unit.....	4
Accumulator.....	6
Main valve	7
Restrictor valve	8
Pressure control valve	9
Idle selector.....	11
Stroke selector valve	12
Tie rods	13
Body parts	14
Front head	16
Lower tool bushing	18
Tool.....	19
Seal set	20
Service kit	22
Service kit 2A	23
Greasing block for manual greasing	24
Greasing device kit	25
Greasing device.....	27
Service kit for greasing device RG540 series	29
SDC service indicator	31

GENUINE STANLEY SPARE PARTS

Stanley genuine spare parts are designed and manufactured by using the latest technological knowledge and engineering skills. Stanley spare parts are made of the best available materials with the most advanced manufacturing techniques.

It is important that you use only genuine Stanley spare parts, to ensure easy operation, maintenance and repair of the product. Please note that eventual warranty claims will be handled only if you have used genuine Stanley parts in your Stanley product.

LOCATION OF THE SERIAL NUMBER

It's important to make correct reference to the serial number of the product when ordering spare parts. Identification of serial number is the only proper means of maintaining and identifying parts for a specific product. The location of equipment serial number is pointed in "Operation and maintenance" manual.

SPARE PART ORDERS

Quick spare part deliveries are secured by exact orders.

Required information:

- Name of customer and contact person
 - Order number (when available)
 - Delivery address
 - Mode of delivery (air mail etc.)
 - Required delivery date
 - Invoicing address
 - Model and serial number of the product
 - Name, number and required amount of spare parts
-

PARTS

HOUSING UNIT

HOUSING UNIT

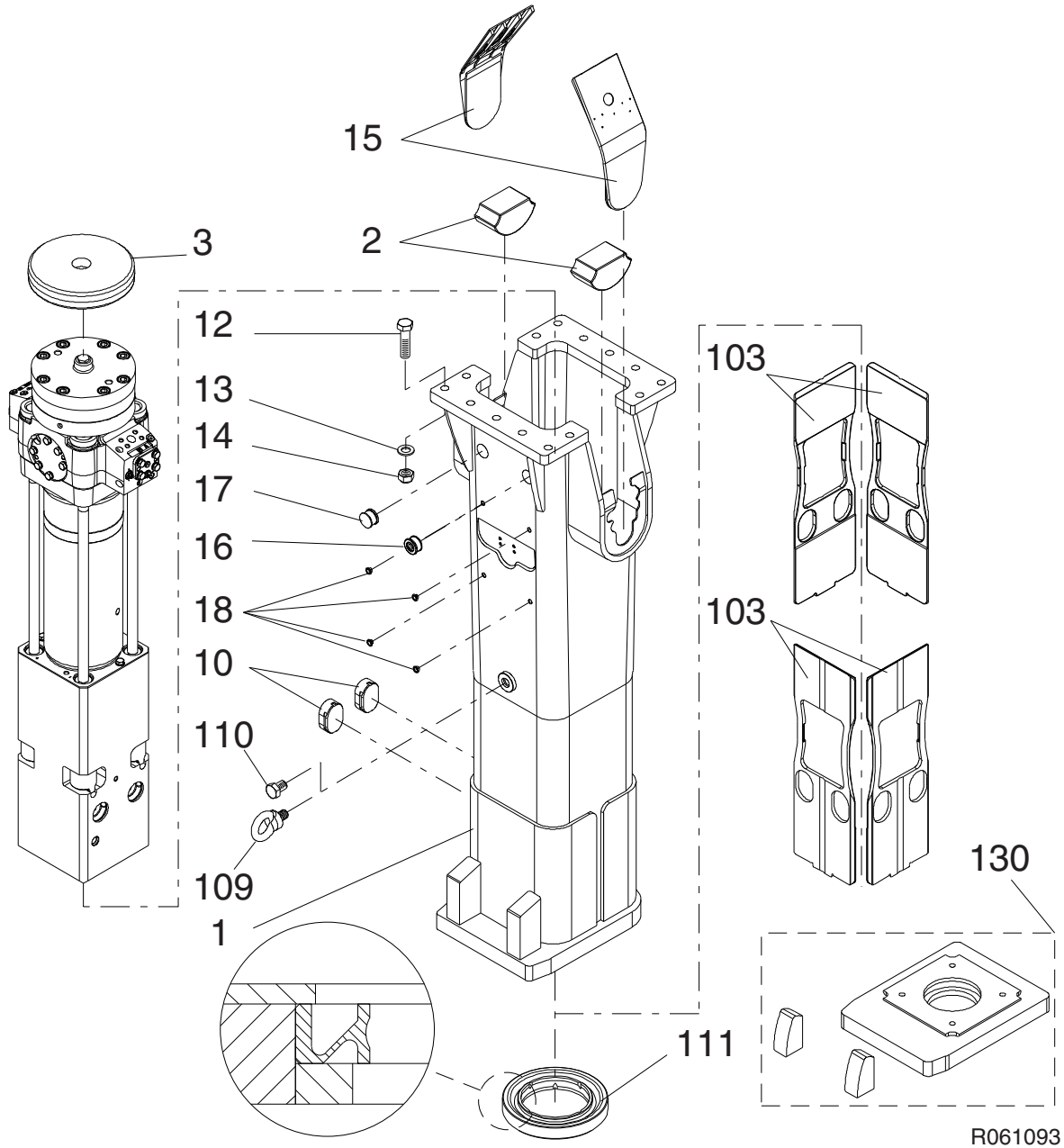

R061093

HOUSING UNIT

Item	Description	Part no.	Specification	Note	Qty
1	Housing	80629			1
2	Pad	78671			2
3	Buffer	78673			1
10	Plug	78675			2
12	Hex. screw	76905	M24x110-12.9 ISO 4014		14
13	Washer	76906	24 ISO 7416		14
14	Lock nut	76907	M24-12 DIN 985		14
15	Shield plate	78676			2
16	Plug	77722			1
17	Plug	78604			1
18	Plug	77716			4
103	Wear plate	78677			4
109	Lifting eye	78612	M30 DIN 580		1
110	Hex. screw	78613	M30x40-8.8 ISO 4017		1
111	Seal	78678			1
130	Wear parts	78679			1
201	Label set (incl. part 201.1)	80635			1
201.1	Safety label set	76832			1

ACCUMULATOR

ACCUMULATOR

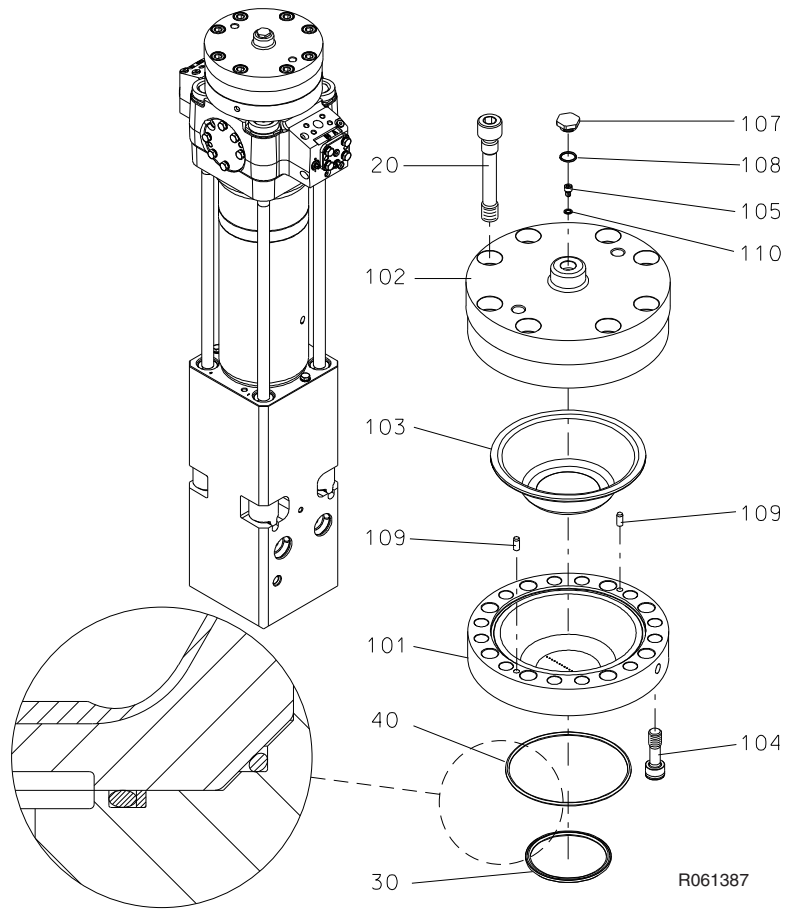

Item	Description	Part no.	Specification	Note	Qty
1	Accumulator (incl. parts 101-110)	78681			1
101	Accumulator bottom	78682			1
102	Accumulator cover	78683			1
103	Membrane	78684			1
104	Accumulator screw	77780			12
105	Filling plug	76921			1
107	Shield plug	76922			1
108	O-ring	76844	D23	*	1
109	Parallel pin	77781	10m6x24 DIN 6325		2
110	Usit-ring	76846	8-13.9-1	*	1
20	Accumulator screw	78685			8
30	Seal	78686	D124	*	1
40	O-ring	78687	D194	*	1
	*) Are included in seal set				

MAIN VALVE

MAIN VALVE

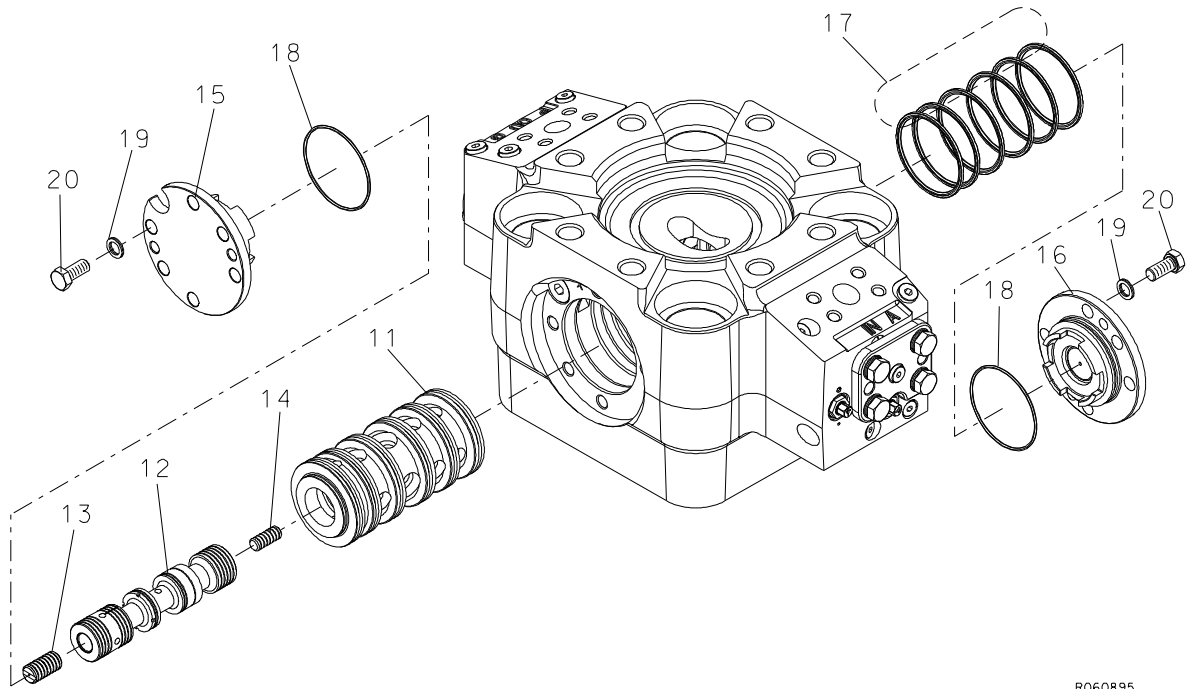

R060895

Item	Description	Part no.	Specification	Note	Qty
11	Main valve bushing	78688			1
12	Main spool	78689			1
13	Spool	78690	D23		1
14	Spool	78691	D16		1
15	Cover	78692			1
16	Cover	78693			1
17	Seal	77790	D110	*	6
18	O-ring	77789	D105	*	2
19	Lock washer	76852	M16 NORD-LOCK		12
20	Hex. screw	76933	M16x35-8.8 ISO 4017		12
	*) Are included in seal set				

RESTRICTOR VALVE

RESTRICTOR VALVE

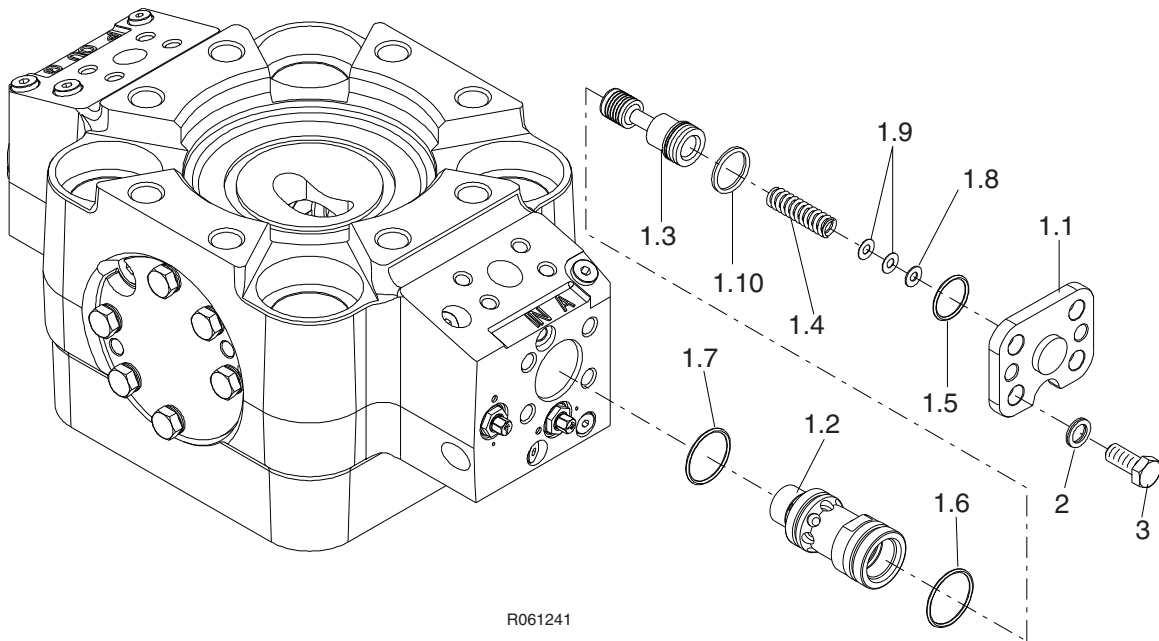

R061241

Item	Description	Part no.	Specification	Note	Qty
1	Restrictor valve (incl. parts 1.1-1.10)	78694			1
1.1	Cover	78695			1
1.2	Valve housing	78696			1
1.3	Spool	78697			1
1.4	Spring	78698			1
1.5	O-ring	76941	D34	*	1
1.6	O-ring	76939	D46	*	1
1.7	O-ring	76940	D44	*	1
1.8	Shim plate	78699	S=1		X
1.9	Shim plate	78700	S=0.5		X
1.10	Seal	76942	D34	*	1
2	Lock washer	76852	M16 NORD-LOCK		4
3	Hex. screw	76933	M16x35-8.8 ISO 4017		4
	*) Are included in seal set				

PRESSURE CONTROL VALVE

PRESSURE CONTROL VALVE

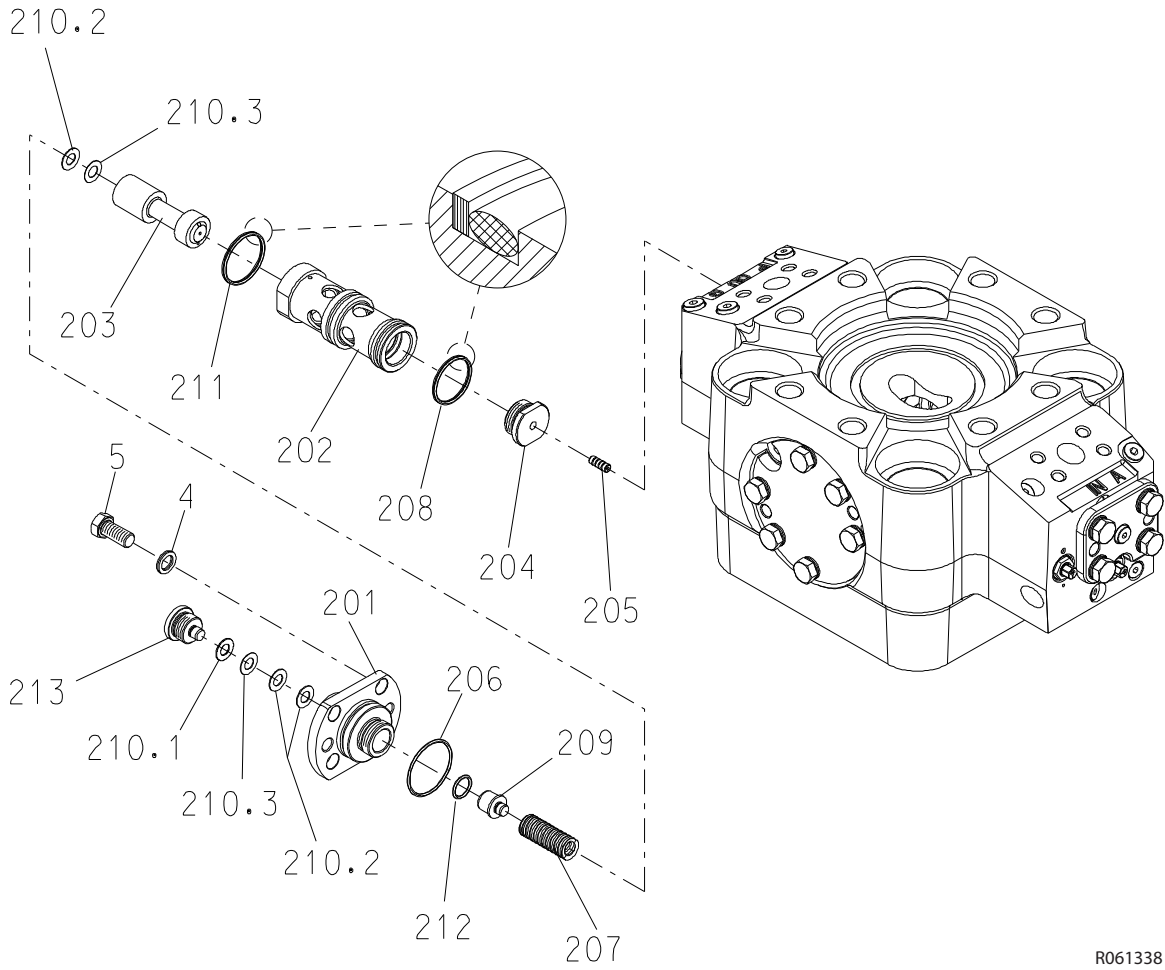

R061338

PRESSURE CONTROL VALVE

Item	Description	Part no.	Specification	Note	Qty
2	Pressure control valve (incl. parts 201-213)	78701			1
201	Cover	77796			1
202	Valve housing	78702			1
203	Spool	78703			1
204	Guide	77799			1
205	Spool	78062	D9		1
206	O-ring	78628	D60	*	1
207	Spring	76950			1
208	Seal	78068	D50	*	1
209	Spring guide	78063			1
210.1	Shim plate	76953	S=0.75		X
210.2	Shim plate	76952	S=1		X
210.3	Shim plate	76951	S=0.5		X
211	Seal	78067	D55	*	1
212	O-ring	78066	D21	*	1
213	Plug	78064			1
4	Lock washer	76852	M16 NORD-LOCK		4
5	Hex. screw	76933	M16x35-8.8 ISO 4017		4
	*) Are included in seal set				

IDLE SELECTOR

IDLE SELECTOR

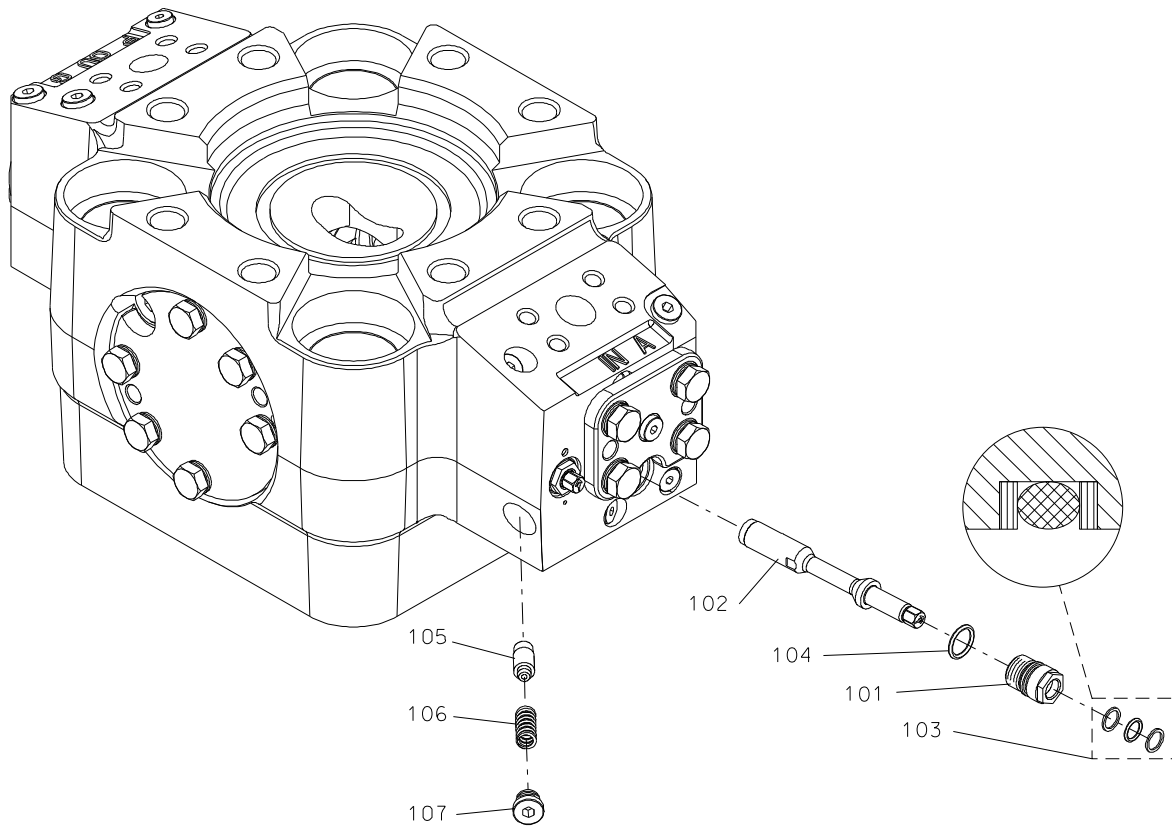

R060898

Item	Description	Part no.	Specification	Note	Qty
1	Valve (incl. parts 101-104)	78704			1
101	Cover	78705			1
102	Spool	78706			1
103	Seal	78707	D13	*	1
104	O-ring	78708	D20	*	1
105	Pin	78709			1
106	Spring	78710	Danly 9-1006-11		1
107	Flange plug	76847	BSP 3/8		1
	*) Are included in seal set				

STROKE SELECTOR VALVE

STROKE SELECTOR VALVE

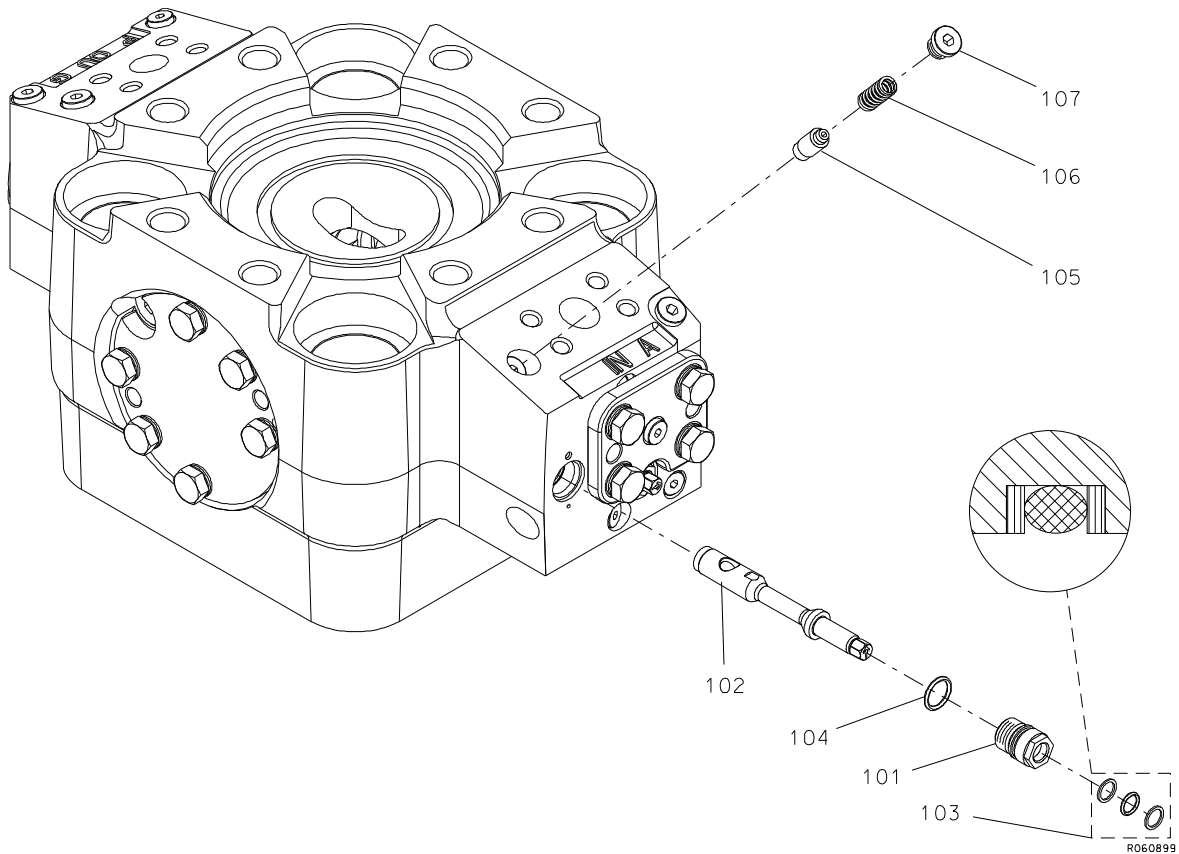

Item	Description	Part no.	Specification	Note	Qty
1	Valve (incl. parts 101-104)	78704			1
101	Cover	78705			1
102	Spool	78706			1
103	Seal	78707	D13	*	1
104	O-ring	78708	D20	*	1
105	Pin	78709			1
106	Spring	78710	Danly 9-1006-11		1
107	Flange plug	76847	BSP 3/8		1
	*) Are included in seal set				

TIE RODS

TIE RODS

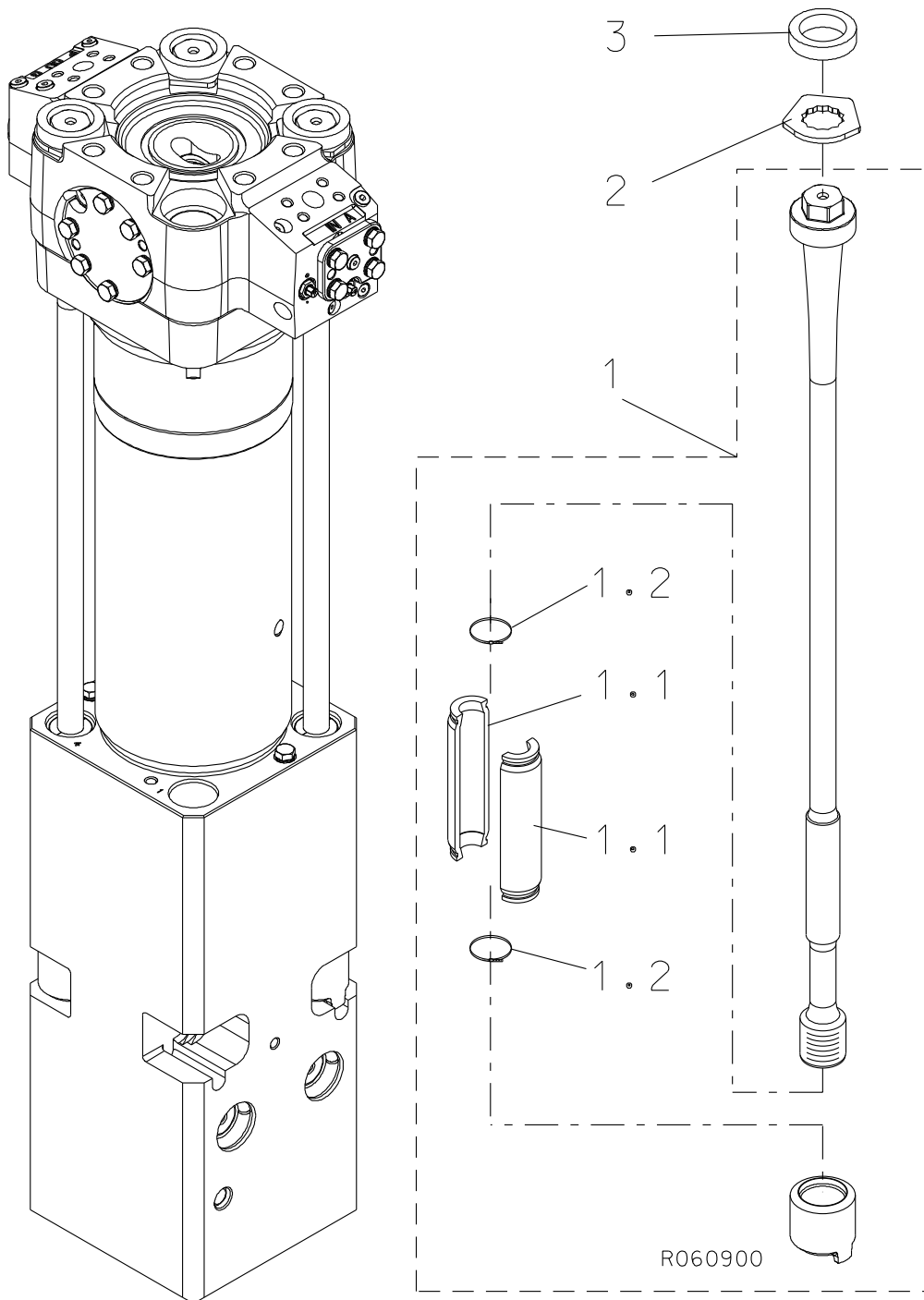

Item	Description	Part no.	Specification	Note	Qty
1	Tie rod (incl. parts 1.1-1.2)	78711			4
1.1	Vibration dampening element	78712			2
1.2	Cable tie	76962			2
2	Lock plate	78713			4
3	Rubber ring	78714			4

BODY PARTS

BODY PARTS

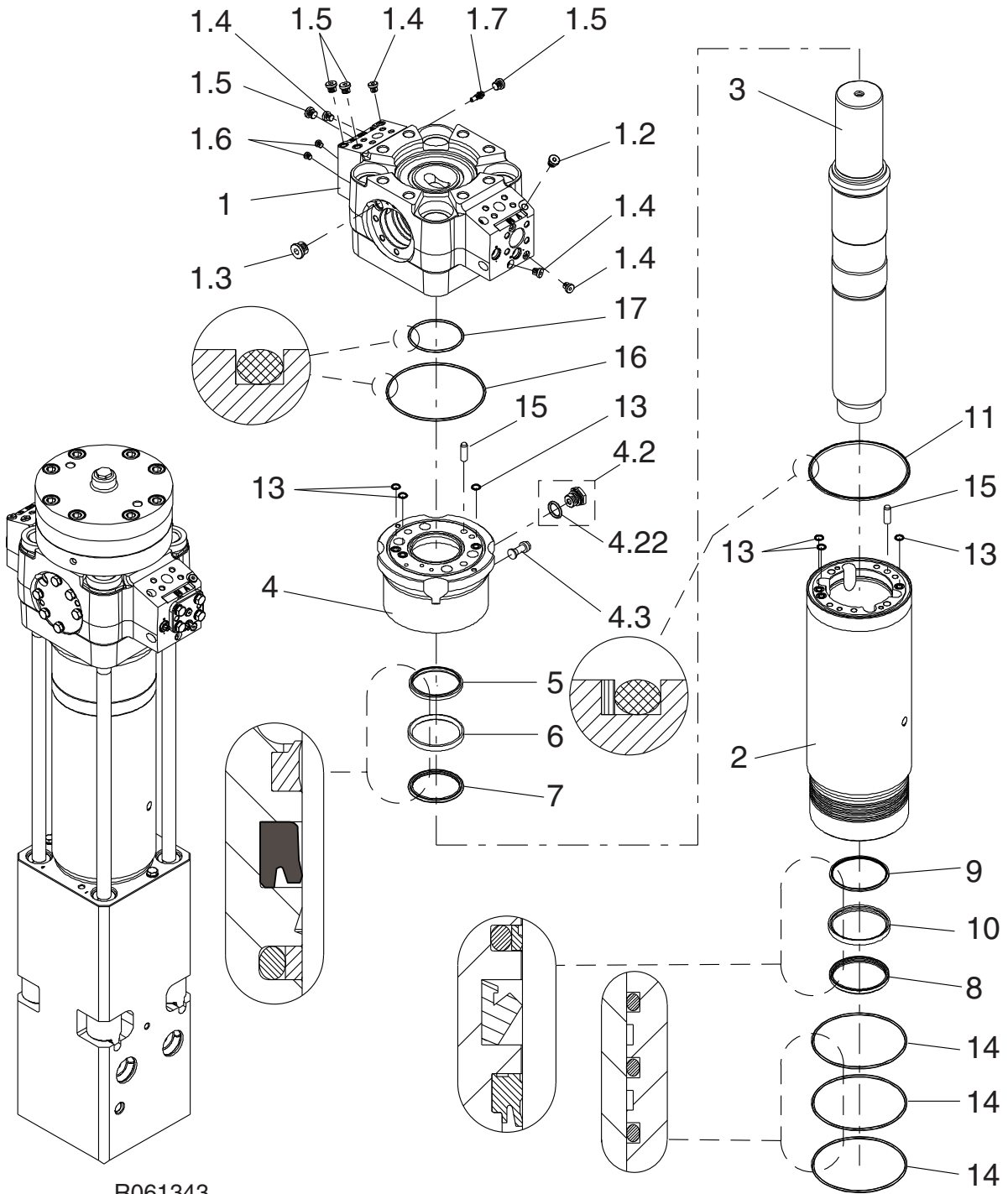

R061343

BODY PARTS

Item	Description	Part no.	Specification	Note	Qty
1	Valve body (incl. parts 1.2-1.7)	78715			1
1.2	Breather	76971			1
1.3	Flange plug	76859	R3/4		1
1.4	Flange plug	76969	R1/4		4
1.5	Flange plug	76847	R3/8		4
1.6	Flange plug	76970	R1/8		2
1.7	Nozzle	78716			1
2	Cylinder	78717			1
3	Piston	78718			1
4	Seal carrier (incl. parts 4.2-4.4)	78719			1
4.2	Breather (incl. part 4.22)	78720			1
4.22	O-ring	78721	D27	*	1
4.3	Plug	78722			1
5	Wiper	78723	D119	*	1
6	Seal	78724	D120	*	1
7	Seal	78725	D118	*	1
8	Wiper	78726	D135	*	1
9	Seal	78727	D135	*	1
10	Seal	78728	D135	*	1
11	Seal	78729	D239	*	1
13	O-ring	78730	D17	*	6
14	O-ring	78648	D229	*	3
15	Parallel pin	78731	16m6x50 DIN 6325		2
16	O-ring	78732	D239	*	1
17	O-ring	78733	D129	*	1
	*) Are included in seal set				

FRONT HEAD

FRONT HEAD

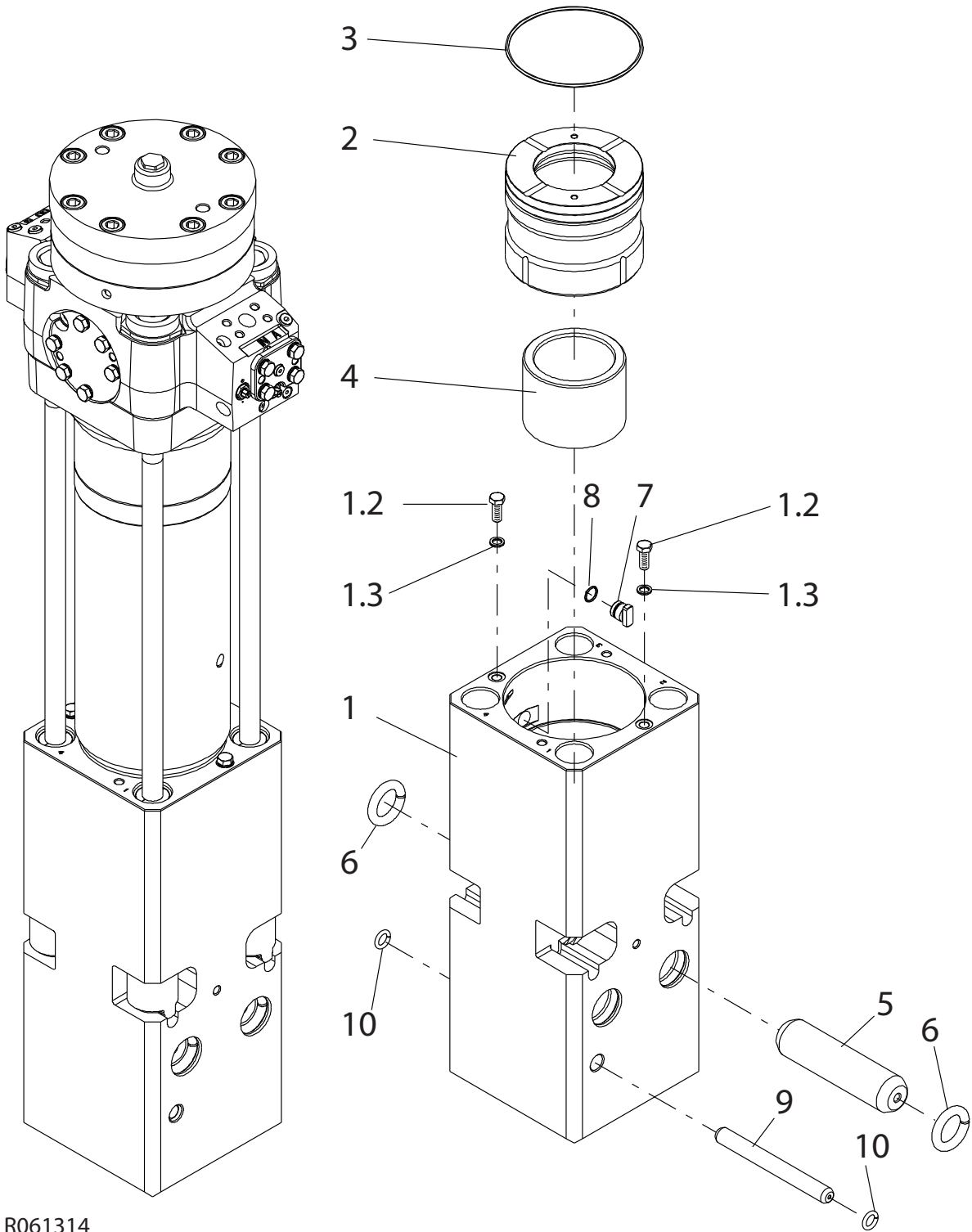

R061314

FRONT HEAD

Item	Description	Part no.	Specification	Note	Qty
1	Front head (incl. parts 1.2-1.3)	78734			1
1.2	Hex. socket screw	78735	M16x40-12.9 ISO 4017		2
1.3	Lock washer	76852	M16 NORD-LOCK		2
2	Thrust ring	78736			1
3	O-ring	78648	D229	*	1
4	Upper tool bushing	78737			1
5	Tool retaining pin	78738			2
6	Ring	78652			4
7	Wedge	78739			1
8	O-ring	76838	D24	*	1
9	Retaining pin	78740	D30		1
10	Rubber ring	78741		*	2
	*) Are included in seal set				

LOWER TOOL BUSHING

LOWER TOOL BUSHING

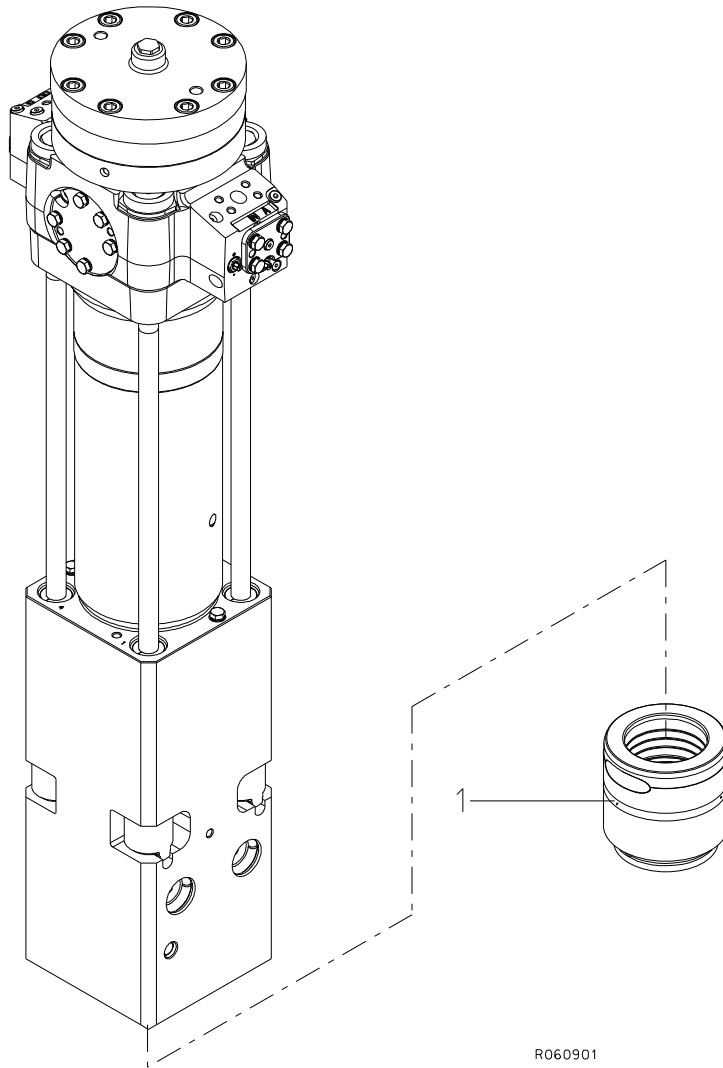

Item	Description	Part no.	Specification	Note	Qty
1	Lower tool bushing	78742			1

TOOL

TOOL

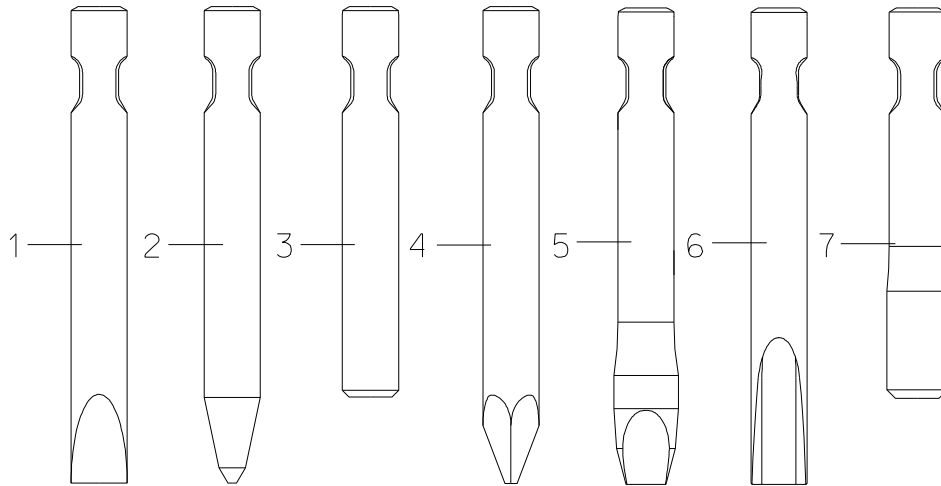

R060731

Item	Description	Part no.	Specification	Note	Qty
1	Chisel	78743	L = 1200 mm, W = 132 kg, D = 142 mm		1
2	Moil point	78744	L = 1200 mm, W = 128 kg, D = 142 mm		1
3	Blunt	78745	L = 1050 mm, W = 124 kg, D = 142 mm		1
4	Pyramid	78746	L = 1200 mm, W = 132 kg, D = 142 mm		1
5	Limestone Chisel	78748	L = 1200 mm, W = 140 kg, D = 142 mm		1
6	Hard Rock Chisel	78747	L = 1200 mm, W = 132 kg, D = 142 mm		1
7	Super Blunt	78749	L = 1100 mm, W = 138 kg, D = 148 mm		1

SEAL SET

SEAL SET

Seal set 78750

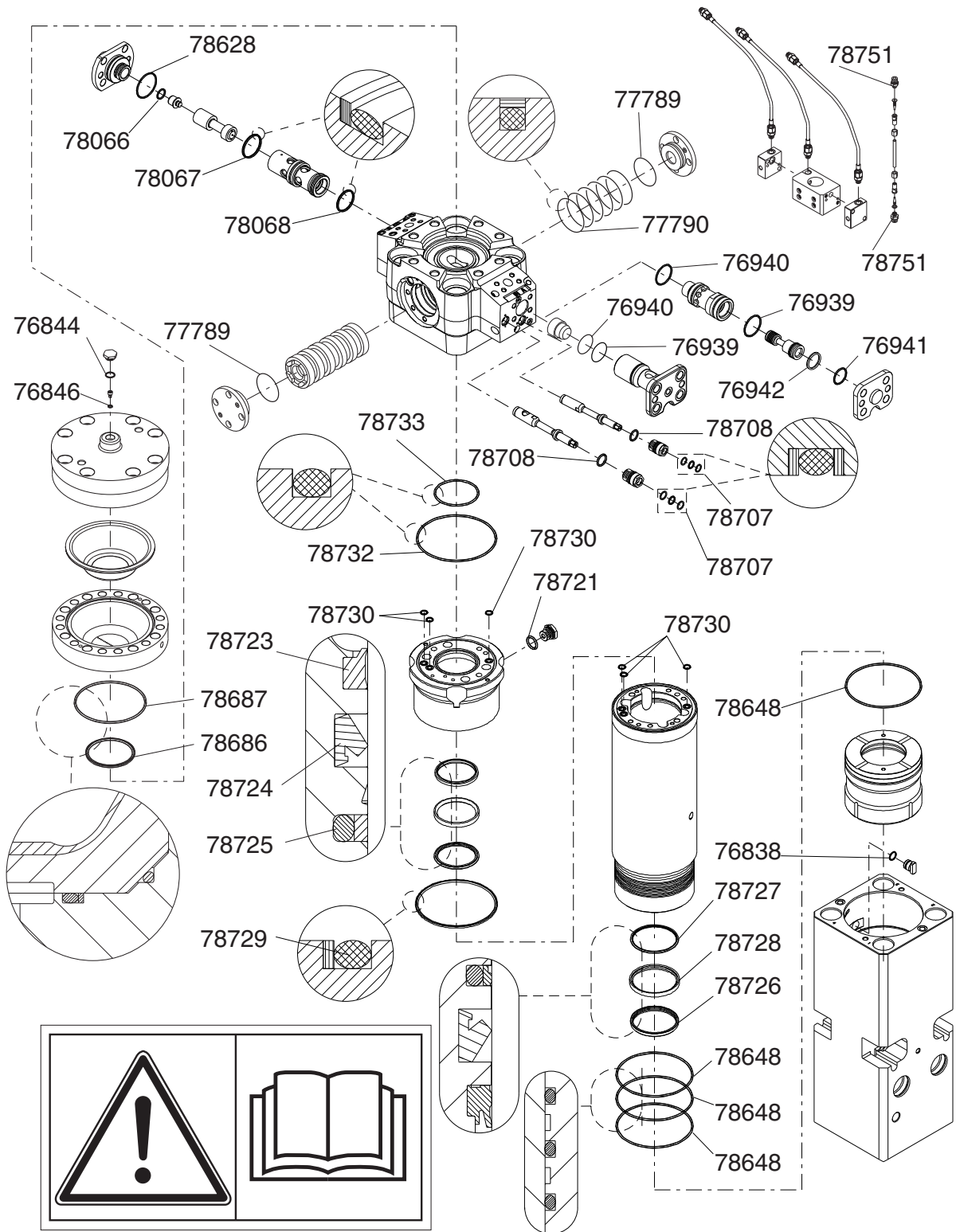

This summary only indicates the position of the seals. It must NOT be used as assembly instruction. Read the manual.

LB060005

SEAL SET

Item	Description	Part no.	Specification	Note	Qty
Kit	Seal set (incl. parts 1-31)	78750			1
1	O-ring	76844	D23		1
2	Usit-ring	76846	8-13.9-1		1
3	Seal	78686	D124		1
4	O-ring	78687	D194		1
5	Seal	78707	D13		2
6	O-ring	78708	D20		2
7	O-ring	78628	D60		1
8	Seal	78068	D50		1
9	Seal	78067	D55		1
10	O-ring	78066	D21		1
11	Seal	77790	D110		6
12	O-ring	77789	D105		2
13	O-ring	76939	D46		1
14	O-ring	76940	D44		1
15	O-ring	78648	D229		4
16	O-ring	76838	D24		1
17	O-ring	78721	D27		1
18	Wiper	78723	D119		1
19	Seal	78724	D120		1
20	Seal	78725	D118		1
21	Wiper	78726	D135		1
22	Seal	78727	D135		1
23	Seal	78728	D135		1
24	Seal	78729	D239		1
25	O-ring	78730	D17		6
26	O-ring	78732	D239		1
27	O-ring	78733	D129		1
28	O-ring	78751	D9		6
29	O-ring	76941	D34		1
30	Seal	76942	D34		1
31	Rubber ring	78741			2
	The seals for greasing device are not included in this seal set. They are included in the service kit for greasing device.				

SERVICE KIT

SERVICE KIT

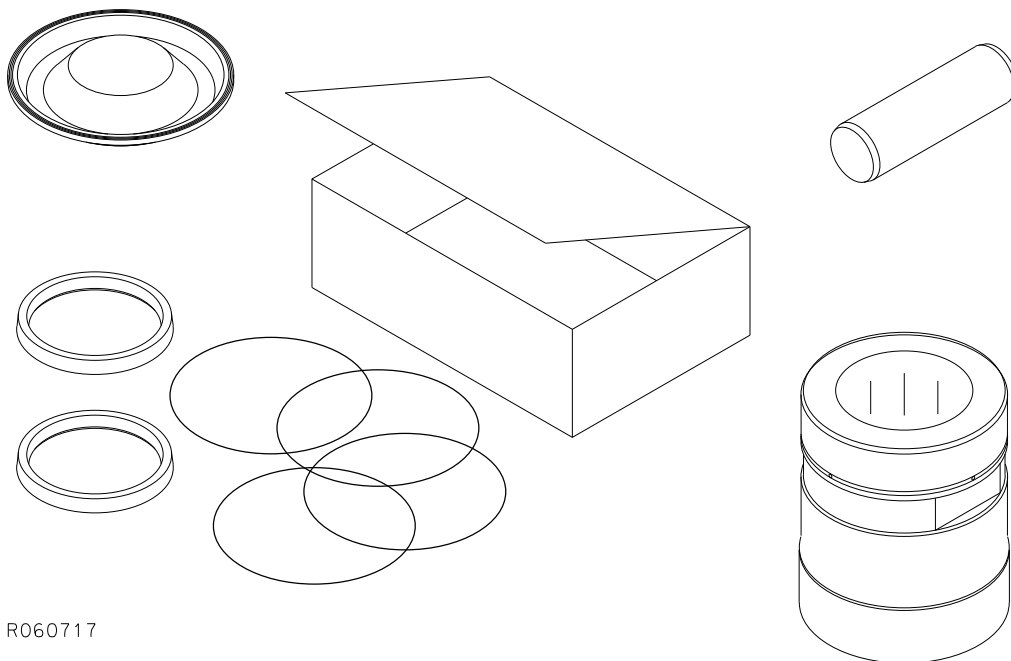

R060717

Item	Description	Part no.	Specification	Note	Qty
Kit	Service kit (incl. parts 1 - 4)	78752			1
1	Membrane	78684			1
2	Tool retaining pin	78738			2
3	Lower tool bushing	78742			1
4	Seal set	78750			1

SERVICE KIT 2A

SERVICE KIT 2A

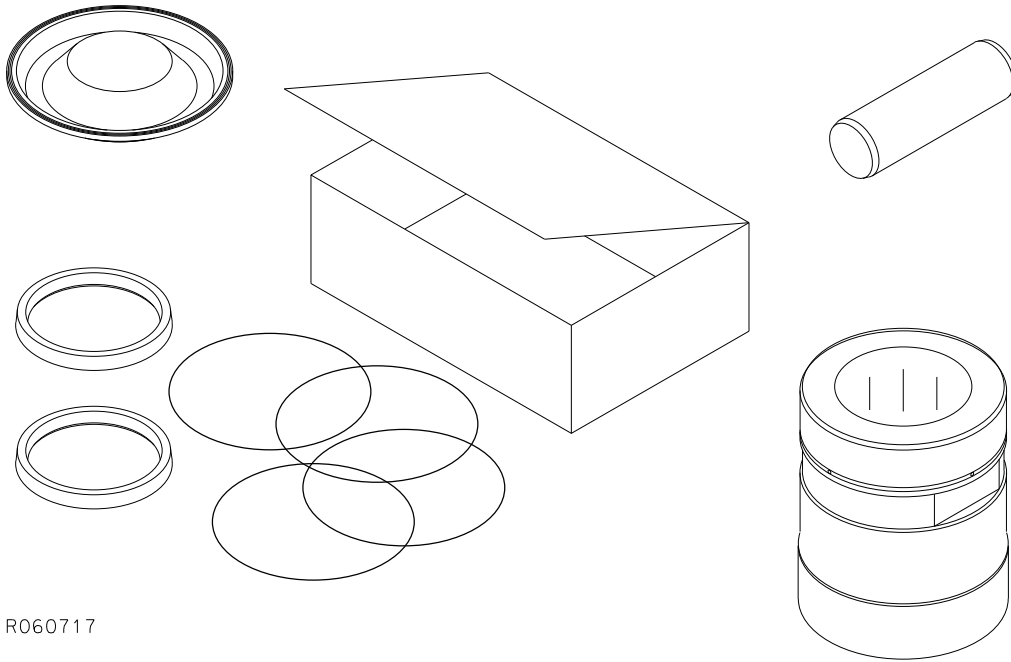

R060717

Item	Description	Part no.	Specification	Note	Qty
Kit	Service kit (incl. parts 1 - 4)	78754			1
1	Pad	78671			2
2	Buffer	78673			1
3	Wear plate	78677			4
4	Upper tool bushing	78737			1

GREASING BLOCK FOR MANUAL GREASING

GREASING BLOCK FOR MANUAL GREASING

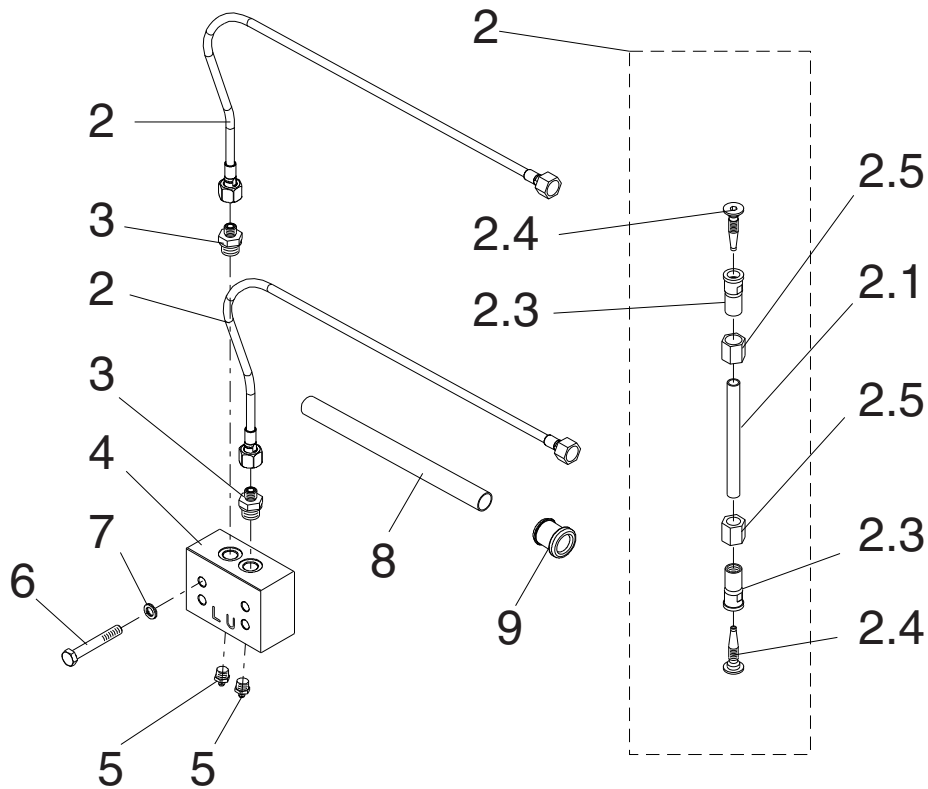

R061085

Item	Description	Part no.	Specification	Note	Qty
Kit	Greasing block for manual greasing (incl. parts 3-7)	78755			1
2	Hose assembly (incl. parts 2.1-2.5)	78756			2
2.1	Hose	78757			1
2.3	Sleeve	77707			2
2.4	Insert	77708			2
2.5	Nut	77710			2
3	Connector	77712	BSPP 1/4		2
4	Body	78758			1
5	Grease zerk	77714	R1/4		2
6	Hex. screw	78759	M10x70-8.8 ISO 4014		4
7	Lock washer	77725	M10 NL10sp NORD-LOCK		4
8	Shield	77723			1
9	Rubber bushing	77722			1

GREASING DEVICE KIT

GREASING DEVICE KIT

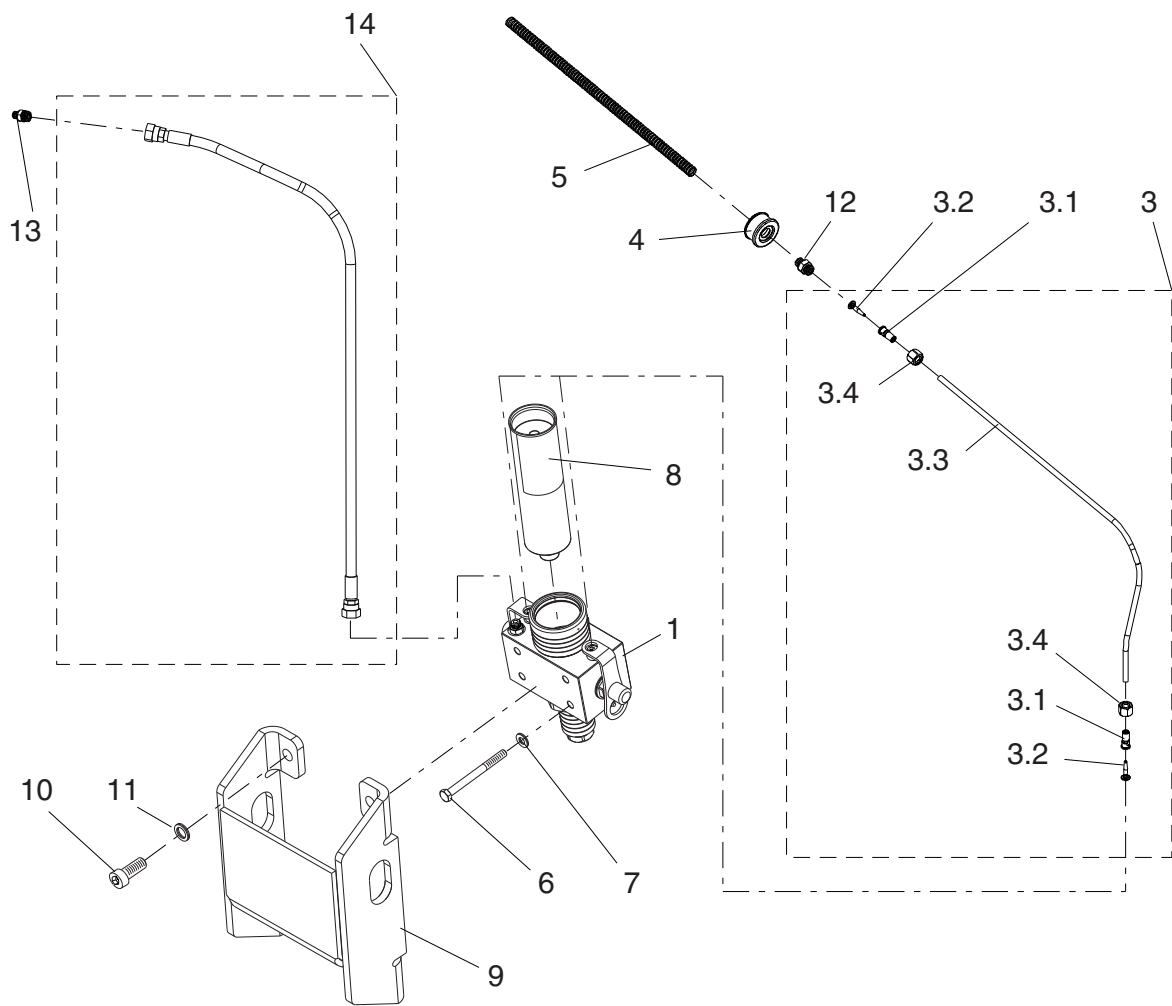

R061446

GREASING DEVICE KIT

Item	Description	Part no.	Specification	Note	Qty
kit	Greasing device retrofit kit (incl. parts 1-14)	78760			1
1	Greasing device RG542	78761			1
3	Hose assembly (incl. parts 3.1-3.4)	77720			2
3.1	Sleeve	77707			2
3.2	Insert	77708			2
3.3	Hose	77721			1
3.4	Nut	77710			2
4	Rubber bushing	77722			1
5	Shield	77723			1
6	Hex. screw	77724	M10x110-8.8 ISO 4014		4
7	Lock washer	77725	M10 NL10sp NORD-LOCK		4
8	Grease cartridge	77726	Special tool grease, Greasing device cartridge. Greasing device cartridges are also sold in boxes of 24.		1
9	Shield	78762			1
10	Hex. socket screw	77728	M16x35-8.8 ISO 4762		4
11	Lock washer	76852	M16 NORD-LOCK		4
12	Connector	77711	BSPP 3/8		2
13	Connector	77712	BSPP 1/4		1
14	Hose assembly	77729			1

GREASING DEVICE

Item	Description	Part no.	Specification	Note	Qty
1	Greasing device RG542 (incl. parts 2-21)	78761			1
2	Dozer (incl. parts 2.1-2.14)	77730			2
2.1	Plug	77731			1
2.2	Nut	77732	M12x1 DIN 934		1
2.3	Lock washer	76854	M24 NORD-LOCK	*	1
2.4	O-ring	77733	D21	*	1
2.5	Adjusting screw	77734			1
2.6	O-ring	77735	D8	*	1
2.7	O-ring	77736	D11	*	2
2.8	Spring	77737		*	1
2.9	Piston	77738			1
2.10	O-ring	77739	D7	*	1
2.11	Piston	77740		*	1
2.12	Body	77741			1
2.13	O-ring	77742	D15	*	1
2.14	Shim plate	77743		*	1
3	Grease zerk	77714	BSP 1/4	*	2
4	Plug	77744		*	2
5	Locking plate	77745			2
6	Body	78763			1
7	Cartridge holder	78764			1
8	Check valve	77748			1
9	O-ring	77749	D19	*	1
10	O-ring	77750	D62	*	1
11	O-ring	77751	D71	*	1
12	O-ring	77752	D52	*	2
13	Guide ring	77753		*	1
14	Seal	77754		*	1
15	Spring housing	77755			1
16	Spring	77756			1
17	Piston	77757			1
18	Nut	77758			1
19	Lock plate	77759		*	1
20	Hex. socket screw	77760	M8x10-8.8 ISO 4762	*	1
21	Connector	77712	BSPP 1/4		3
kit	Seal set for greasing device	77761			1
	*) Are included in seal set for greasing device				

SERVICE KIT FOR GREASING DEVICE RG540 SERIES

SERVICE KIT FOR GREASING DEVICE RG540 SERIES

Service kit 953385

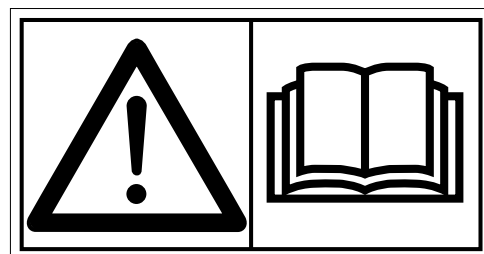
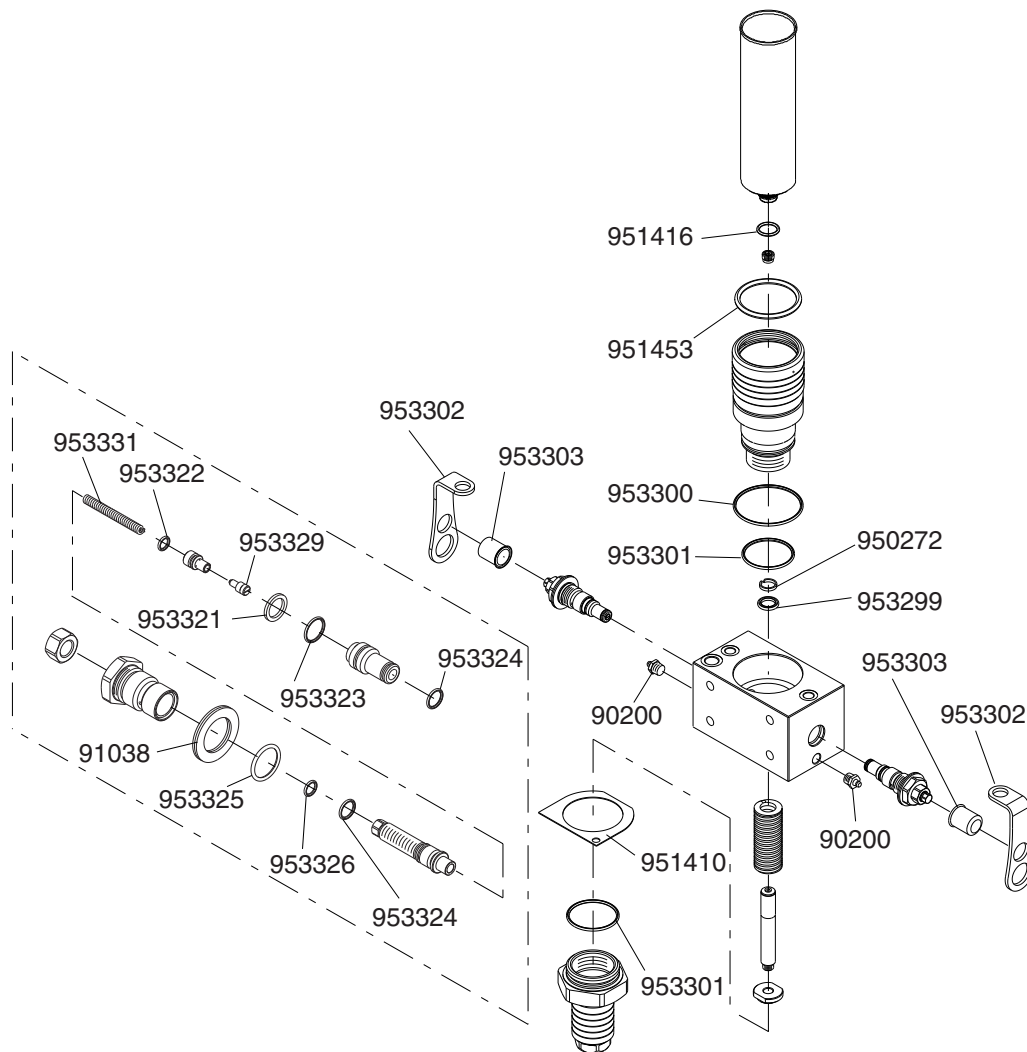

This summary only indicates the position of the seals. It must NOT be used as assembly instruction. Read the manual.

R061096

SERVICE KIT FOR GREASING DEVICE RG540 SERIES

Item	Description	Part no.	Specification	Note	Qty
Kit	Service kit for greasing device (incl. parts 1-19)	77761			1
1	Lock plate	77759			1
2	Plug	77744			2
3	Guide ring	77753			1
4	Seal	77754			1
5	O-ring	77751	D71		1
6	O-ring	77750	D62		1
7	O-ring	77752	D52		2
8	O-ring	77749	D19		1
9	O-ring	77735	D8		2
10	O-ring	77733	D21		2
11	O-ring	77736	D11		4
12	O-ring	77742	D15		2
13	O-ring	77739	D7		2
14	Shim plate	77743			2
15	Spring	77737			2
16	Piston	77740			2
17	Lock washer	76854	M24 NORD-LOCK		2
18	Grease zerk	77714	R1/4		2
19	Locking plate	77745			2
	Service kit for greasing device is not included in the breakers seal set.				

SDC SERVICE INDICATOR

SDC SERVICE INDICATOR

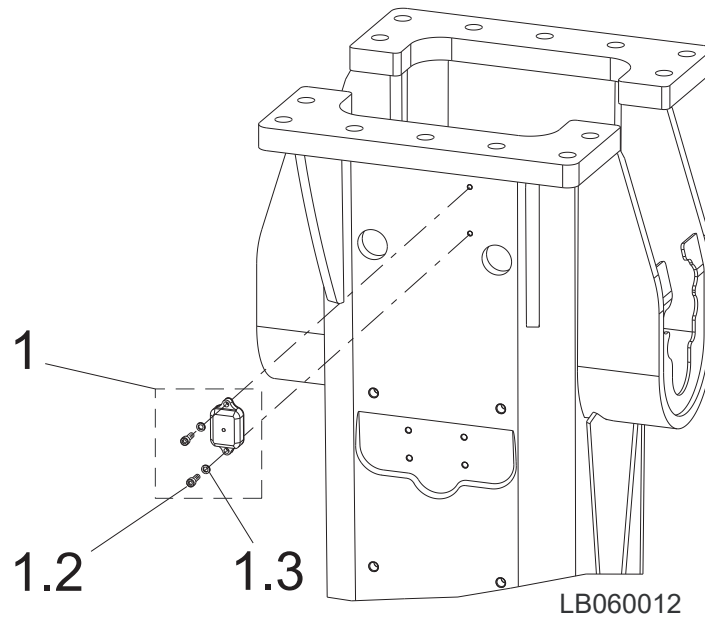

Item	Description	Part no.	Specification	Note	Qty
1	SDC service indicator (incl. parts 1.2-1.3)	77762			1
1.2	Hex. socket screw	79177	M8x25- 8.8 ISO 4762		2
1.3	Lock washer	79178	M8 NORD-LOCK		2

STANLEY

Stanley, 1538 Highway 2,
Two Harbors, MN 55616 USA

27-20-14133-27-188-329
42-20-14133-42-192-343