

STANLEY®

RW30 ROBOTIC WELDER



USER'S MANUAL Safety, Operation and Maintenance



CE

GENERAL INFORMATION

WARNING

SERIOUS INJURY OR DEATH COULD RESULT FROM THE
IMPROPER REPAIR OR SERVICE OF THIS TOOL.

REPAIRS AND / OR SERVICE TO THIS TOOL MUST ONLY BE DONE BY AN AUTHORIZED AND CERTIFIED
DEALER.

MAKE NO ALTERATIONS OR MODIFICATIONS TO THE TOOL.
SERIOUS INJURY COULD RESULT FROM IMPROPER CHANGES.

MODIFICATIONS OR ALTERATIONS COULD ALTER THE PERFORMANCE OR INTEGRITY OF THE TOOL.

IMPORTANT

To fill out a Product Warranty Validation form, and for information on your warranty,
visit Stanleyhydraulics.com and select the Company tab, Warranty.

(NOTE: The warranty Validation record must be submitted to validate the warranty).

TABLE OF CONTENTS

SAFETY SYMBOLS	5
LOCAL SAFETY REGULATIONS	5
SAFETY PRECAUTIONS.....	6
OPERATION.....	11
OVERVIEW.....	11
PREPARING THE RW30 FOR OPERATION	11
CLAW VERSION	11
CLAMP VERSION	12
CONNECTING THE WIRE FEED/WELDING TIP TO THE RW30	13
SETTING THE STICK OUT	13
OPERATING THE RW30 & THE CHARLIE CONTROL UNIT	14
INFORMATION ON DATA TRACKING	16
MANUAL DATA ENTRY	16
AUTOMATIC DATA ENTRY	16
OPERATOR DIALOGUE	17
STOP AND RESTART OF WELDING CYCLE.....	20
ERROR MESSAGES.....	20
EQUIPMENT MAINTENANCE & CARE.....	22
TROUBLESHOOTING	22
SPECIFICATIONS.....	24
RW30 HEATER	25
ACCESSORIES.....	26
SPARE PARTS.....	27
RW30110 / RW30112 PARTS LIST & ILLUSTRATION	29
RW30120 PARTS LIST & ILLUSTRATION	30
RW30110 / RW30112 / RW30120 LEFT SIDE ILLUSTRATION.....	31
RW30110 / RW30112 / RW30120 RIGHT SIDE ILLUSTRATION	32
RW30110 / RW30112 / RW30120 MOTOR BOARD ILLUSTRATION	33
RW30110 / RW30112 / RW30120 SUPPORT PLATFORM ILLUSTRATION	34
RW30110 / RW30112 / RW30120 SUPPORT ASSEMBLY	35
CLAMP ASSEMBLIES.....	36
TORCH SUPPORT.....	37
TORCH SUPPORT (PULL GUN)	38
WARRANTY	39

SERVICING: This manual contains safety, operation, and routine maintenance instructions. Stanley Hydraulic Tools recommends that servicing of hydraulic tools, other than routine maintenance, must be performed by an authorized and certified dealer. Please read the following warning.

DECLARATION OF CONFORMITY

DECLARATION OF CONFORMITY
 ÜBEREINSTIMMUNGS-ERKLÄRUNG
 DECLARATION DE CONFORMITE CEE
 DECLARACION DE CONFORMIDAD
 DICHIARAZIONE DI CONFORMITA



I, the undersigned:
 Ich, der Unterzeichnende:
 Je soussigné:
 El abajo firmante:
 Io sottoscritto:

Weisbeck, Andy

Surname and First names/Familiennamen und Vornamen/Nom et prénom/Nombre y apellido/Cognome e nome

hereby declare that the equipment specified hereunder:
 bestätige hiermit, daß erklaren Produkt genannten Werk oder Gerät:
 déclare que l'équipement visé ci-dessous:
 Por la presente declaro que el equipo se especifica a continuación:
 Dichiaro che le apparecchiature specificate di seguito:

- Category: **Robotic Welder**
 Kategorie:
 Catégorie:
 Categoria:
 Categoría:
- Make/Marke/Marque/Marca/Marca **Stanley**
- Type/Typ/Type/Tipo/Tipo: **RW30**
- Serial number of equipment:
 Seriennummer des Geräts:
 Numéro de série de l'équipement:
 Numero de serie del equipo:
 Matricola dell'attrezzatura:

All

Has been manufactured in conformity with
 Wurde hergestellt in Übereinstimmung mit
 Est fabriqué conformément
 Ha sido fabricado de acuerdo con
 E' stata costruita in conformità con

Directive/Standards Richtlinie/Standards Directives/Normes Directriz/Los Normas Direttiva/Norme	No. Nr Numéro No n.	Approved body Prüfung durch Organisme agréé Aprobado Collaudato
CEE	89/336/CEE:03/05/89	J. Sauron S.A. CTF - France 19 rue Pierre JOSSE – Z.I. Les Bordes C.E. 2413 – 91924 BONDOUFLE Cedex
CEE	92/31/CEE:28/04/92	
CEE	93/68/CEE:22/07/93	
CEE	1999/5/CEE:09/03/99	
CEE	73/23/CEE:19/02/73	
CEE	93/68/CEE:22/07/93	
EN	60974/1:06/00	
EN	60974/1/1A:04/01	
EN	169:12/92	
EN	50199:01/97	
Machinery Directive Directive	2006/42/EC:2006 2004/108/EC:15/12/04	Self

- Special Provisions/Spezielle Bestimmungen/Dispositions particulières/Provisiones especiales/Disposizioni speciali: **None**
- Representative in the Union: **Patrick Vervier, Stanley Dubuis 17-19, rue Jules Berthonneau-BP 3406 41034 Blois Cedex, France.**
 Vertreter in der Union/Représentant dans l'union/Representante en la Union/Rappresentante presso l'Unione

Done at/Ort/Fait à/Dado en/Fatto a Stanley Hydraulic Tools, Milwaukie, Oregon USA Date/Datum/le/Fecha/Data 6-22-11

Signature/Unterschrift/Signature/Firma/Firma

Position/Position/Fonction/Cargo/Posizione Director of Product Development

SAFETY SYMBOLS

Safety symbols and signal words, as shown below, are used to emphasize all operator, maintenance and repair actions which, if not strictly followed, could result in a life-threatening situation, bodily injury or damage to equipment.



This is the safety alert symbol. It is used to alert you to potential personal injury hazards. Obey all safety messages that follow this symbol to avoid possible injury or death.



This safety alert and signal word indicate an imminently hazardous situation which, if not avoided, will result in death or serious injury.



This safety alert and signal word indicate a potentially hazardous situation which, if not avoided, could result in death or serious injury.



This safety alert and signal word indicate a potentially hazardous situation which, if not avoided, may result in minor or moderate injury.



This signal word indicates a potentially hazardous situation which, if not avoided, may result in property damage or damage to the equipment.



This signal word indicates a situation which, if not avoided, may result in damage to the equipment.

Always observe safety symbols. They are included for your safety and for the protection of the tool.

LOCAL SAFETY REGULATIONS

Enter any local safety regulations here. Keep these instructions in an area accessible to the operator and maintenance personnel.

SAFETY PRECAUTIONS

Tool operators and maintenance personnel must always comply with the safety precautions given in this manual and on the stickers and tags attached to the tool and hose.

These safety precautions are given for your safety. Review them carefully before operating the tool and before performing general maintenance or repairs.

Supervising personnel should develop additional precautions relating to the specific work area and local safety regulations. If so, place the added precautions in the space provided on page 5.

The RW30 Robotic Welder will provide safe and dependable service if operated in accordance with the instructions given in this manual. Read and understand this manual and any stickers and tags attached to the tool before operation. Failure to do so could result in personal injury or equipment damage.

SHOCK HAZARD



Contact with live electrical parts can cause fatal accidents or serious burns. The electrode work piece circuit is live when electricity is supplied to the outlet. The supply circuit and the internal circuits of the machine are also live when the current is switched on. When welding the wire, the feeder, the feeder control panel and any metal parts in contact with the wire are also live. Equipment that is incorrectly grounded constitutes a danger.

- Do not touch any live part.
- Wear insulated safety gloves that are both dry and without any holes, plus body protection.
- Insulate yourself from the work piece and from the ground with appropriate insulation material to prevent any physical contact with either the work piece or the ground.
- Switch off the electricity supply or stop the machine before carrying out any maintenance on this machine.
- Install and ground this machine correctly and in compliance with the instruction manual and with local, governmental or national legislation.
- Check the ground of the power supply regularly. Check that the ground wire of the mains cable is correctly connected to the ground terminal in the connection box or that the connector is connected to an output that is correctly grounded.
- When connecting the input, first connect the ground. Double check the connections.
- Check the state of the mains lead and the insulation of the wires regularly – replace the lead immediately if it is damaged as bare wires could cause fatal accidents.
- Switch off the machine when not in use.
- Do not use cables that are worn, damaged, under dimensioned or badly spliced.
- Do not wrap or carry cables around your body.
- If the work piece is to be grounded, ground it with a separate cable – do not use the clamp or the cable of the work piece.
- Do not touch the electrode if you are in contact with the work piece, the ground or another electrode of another machine.
- Only use properly maintained equipment. Repair or replace any damaged components immediately. Carry out maintenance work on the machine according to the instructions manual.

SAFETY PRECAUTIONS

- Wear a safety harness when working above ground.
- Anchor all panels and covers solidly.
- Fix the cable to the work piece or work bench with a good metal-on-metal contact as near as possible to the construction.

WELDING HAZARDS

The RAYS OF THE ARC can burn the eyes and the skin, the NOISE can damage the ears, FLYING SLAG or SPARKS can damage the eyes.

The welding arc produces intense visible and invisible rays (ultraviolet and infrared) which can burn the eyes and skin. The noise generated can damage the ears. Metal particle or slag are projected into the air when chipping, grinding and when joints are cooling.

NOISE

- Wear approved earplugs if the level of noise is high.

RAYS FROM THE ARC

- Wear a welding mask with an appropriate filter screen to protect your eyes and face while welding or watching (see standards EN 169).
- Wear approved eye-protection goggles that give lateral protection.
- Use screens or barriers to protect observers and ask others not to look at arc.

Wear protective clothing made of appropriate fire-proof material and protective shoes.

FUMES AND GASES

Welding produces fumes and gases. Inhaling these substances can be damaging to your health.

- Avoid fumes. Do not inhale fumes.
- When working indoors, ventilate the area and / or use fumes evacuation equipment to evacuate welding fumes and gases.
- If ventilation is insufficient, use an approved air respirator.
- Read the safety recommendations concerning materials (MSDS) and the manufacturer's instructions concerning metals, consumables, coverings, cleansers and degreasing agents.
- Only work in confined places if is well ventilated or wearing an air respirator. Have a properly trained supervisor stand by. Welding fumes and gases can accumulate and starve the atmosphere of oxygen which can lead to fatal accidents. Check there is no danger in breathing the air.
- Do not weld in areas where others are degreasing, cleaning or spraying. Heat and arc rays can react with other vapors and form gases which are highly toxic or an irritant.
- Do not weld coated metals such as galvanized steel, lead or cadmium plated metal until the coating has been removed from the area to be welded. Make sure the area is well ventilated and, if necessary, wear an air respirator. Coatings and the metals they contain can produce toxic fumes when welded.

SAFETY PRECAUTIONS

GAS CYLINDERS

Cylinders of protective welding gas contain gas under pressure. If a cylinder is damaged, it can explode. As cylinders of gas are part of the welding environment, they should be handled with caution.

- Protect gas cylinders from excessive heat, shock, slag, exposed flames, sparks from the welding arc.
- Store cylinders upright in a stationary rack or cylinder holder so that they cannot fall over.
- Keep cylinders away from welding circuits or any other electrical circuit.
- Never place a welding torch on a gas cylinder.
- A welding electrode should never make contact with a gas cylinder.
- Never weld a pressurised cylinder, there is a risk of explosion.
- Only use protective welding gas cylinders, regulators, hoses and fittings designed for this specific purpose, make sure they and associated items are in good condition.
- Do not stand in front of the gas outlet when opening the gas valve on a cylinder.
- Keep the valve protection cap in place except when using or connecting the cylinder.
- Read and follow the instructions concerning the use of cylinders of compressed gas and associated equipment and the other publications listed in the safety standards.

WELDING CAN CAUSE FIRE OR EXPLOSIONS

Welding container-like objects such as tanks, drums or pipelines can cause such objects to burst.

Sparks are projected from the welding arc. The projection of sparks, hot items and hot equipment can cause fire and burns.

Accidental contact of the electrode with metal objects can cause sparks, explosions, overheating or fire. Before welding in such cases, check that there is no danger.

- Protect yourself and others from the projection of sparks and hot metal.
- Do not weld in places where sparks can fall on flammable substances.
- Move flammable substances at least 10.7 metres/35 feet from the welding arc. If this is not possible, cover them carefully with approved protective covering.
- Sparks and other hot welding matter can propagate from one area to another through small cracks and openings.
- Check for any fire that may start and have a fire extinguisher to hand.
- Do not weld container-like objects such as tanks, drums or pipelines unless they have been properly prepared.
- Connect the cable to the work piece as near as possible to the welding area to avoid having to feed the current over long hazardous distances which could cause electrocution or fire.
- Do not use welding equipment to defrost frozen pipes.

SAFETY PRECAUTIONS

- When not in use, remove the rod from the electrode holder.
- Wear grease-free clothing such as leather gloves, a heavy shirt, hemless trousers, safety footwear and headgear.
- Before welding, remove all flammable substances from your pockets such as matches or any type of lighter.

EXHAUST FUMES

Exhaust fumes from the motor can cause fatal accidents. Motors emit toxic exhaust.

- Use the equipment outdoors in an open and well ventilated area.
- When using the equipment indoors, evacuate the exhaust fumes well away from any fresh air intake vents.

MOTOR FUEL







- Do not top up with fuel while smoking or when near a source of sparks or a naked flame.
- Do not fill the tank to the brim – leave space for the fuel to expand.
- Stop the motor and let it cool down before checking or topping up with fuel.
- Do not spill fuel. If fuel spills, clean it up before starting the motor.

MOVING ENGINE PARTS

Moving engine parts such as fans, rotors and driving belts can cause serious hand injury. Articles of loose clothing can also get caught up in them.

- Keep all trap doors, panels, properly in place or closed.
- Only ask qualified personnel to remove the safety devices or other covers in order to carry out when necessary maintenance work or repairs.
- To avoid the motor accidentally starting while carrying out maintenance work or repairs, disconnect the cable from the negative (-) terminal of the battery.
- Keep hands, hair, loose clothing and tools away from engine parts.
- After maintenance work or repairs, replace all trap doors, panels, covers and other protective devices before starting the motor.

SAFETY PRECAUTIONS

	<p>Moving engine parts can cause bodily injury. Before working on the generator, remove the spark plugs or fuel injectors to prevent the motor from accidentally starting. Block the flywheel while working on the generator.</p>
	<p>Metal and dirt particles can cause injury to the eyes. Wear safety glasses that also offer lateral protection.</p>
	<p>Static Electricity can damage the components on the electric board. Before manipulating cards or other components, connect an earth wire to the earth terminal. Use antistatic packing material for storing, moving or transporting PC cards.</p>
	<p>Magnetic fields created by high voltage can interfere with the workings of pacemakers. Pacemaker wearers should keep their distance. Pacemaker wearers should first consult their doctor before going near any place where welding operations are being carried out.</p>
	<p>Read the instructions. Only use original spare parts. Replace the fuel injectors and the fuel system air bleeder as indicated in the motor instruction manual.</p>
	<p>MAKE SURE SPARKS FROM THE ENGINE EXHAUST DO NOT START A FIRE 1. Use an approved spark arrester on the motor exhaust wherever or whenever required – check the legislation in vigour.</p>
	<p>LOW VOLTAGE AND FREQUENCIES can damage electrical equipment such as motors. 1. Switch off or disconnect the equipment before starting or stopping the motor.</p>
	<p>EXCESSIVE WEAR can cause EQUIPMENT TO OVERHEAT. 1. Allow time for equipment to cool. 2. Reduce the current or operating cycle before restarting to weld. 3. Respect the rated operating cycle.</p>



OPERATION

OVERVIEW

The RW30 is an electric arc welding controller to be used for gas-free sheathed wires. It is unbeatable on railroad worksites for performing maintenance and repairs on rails and track devices, railways, tramways, metros, shuttles, etc.

The RW30 after programming automatically executes the reloading of worn sections and accidental surface defects (on treads, rail butt joints, lateral wears, track devices), or the deposits of "safety stainless steel beads".

The RW30 controls the motorized movement of the welding head in the X-axis (length) and Y-axis (width) for work over a surface area of 400 mm by 350 mm.

The RW30 frame is made of composites, aluminum and stainless steel. This principle of construction was retained to combine lightweight and excellent behavior under bad weather conditions.

The RW30 is sold as standard with :

- 1 RW30 Frame
- 1 Rail Gripping Set
- 1 Torch Support for the Pull Gun
- 1 Charlie Control Box with its Connecting Cable

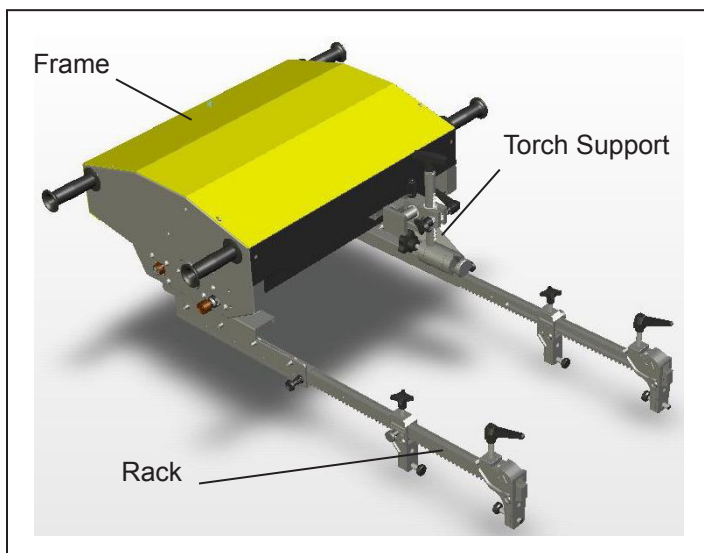

PREPARING THE RW30 FOR OPERATION

CLAW VERSION

1. Position the claw on the rail.



2. Adjust the sliding jaw and tighten.



3. Check the jaw angle and reference supports.

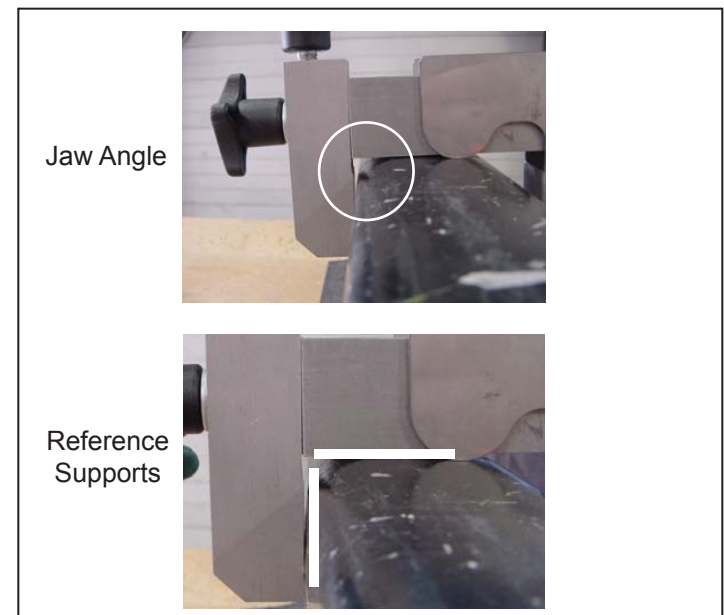

OPERATION

4. Set anti-slip bolt.



5. Assemble the mounting brackets by disengaging the stop pin, inserting the two brackets together and engaging the stop pin to secure.

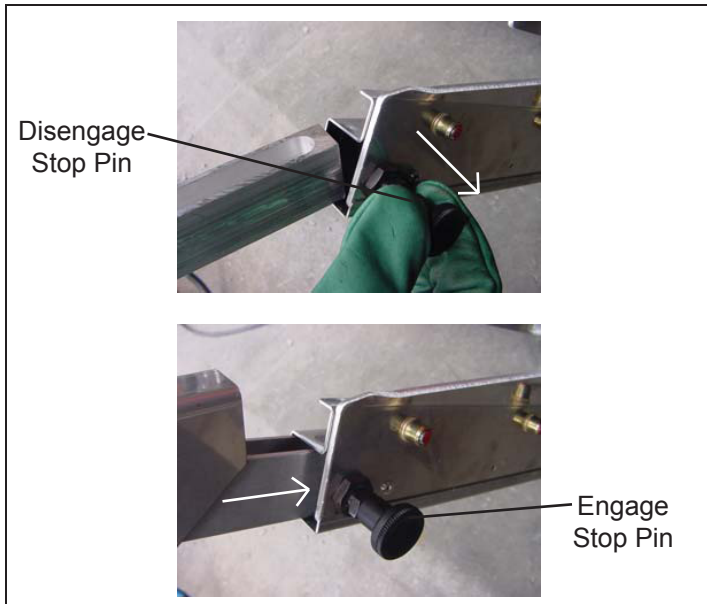

Summary of Steps shown above.

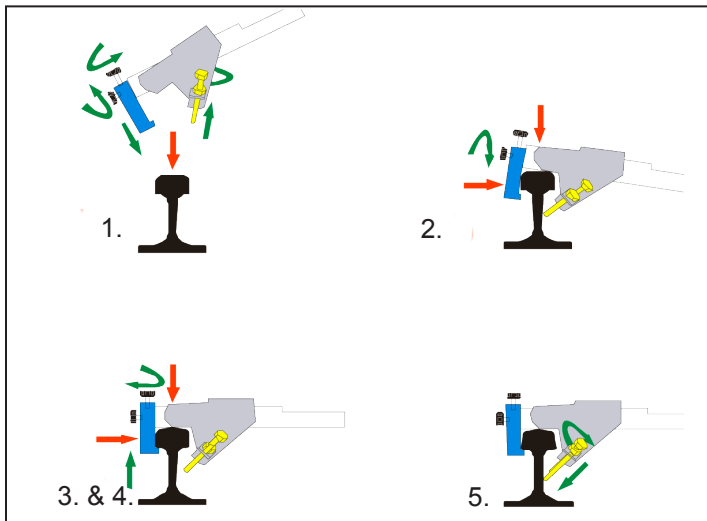

CLAMP VERSION

1. Disengage the stop pin on the mounting bracket, insert the rack, adjust to one of the three positions and engage the stop pin.



2. Slide in and engage the stop pin to the rack.

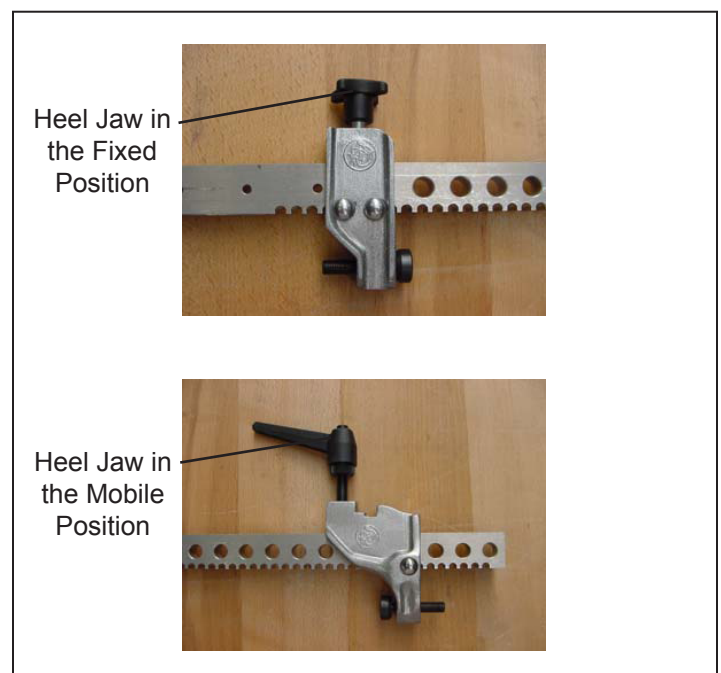
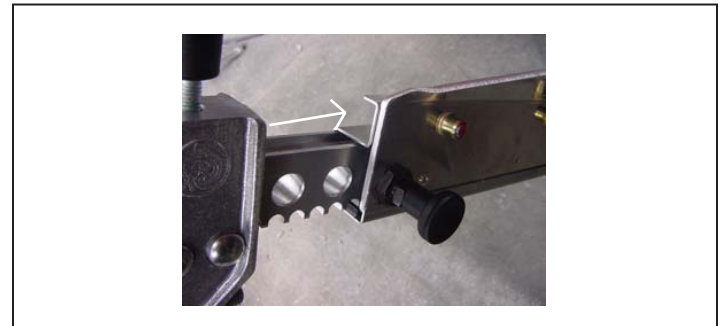

OPERATION

Adjusting the Clamp



Summary of steps shown above.

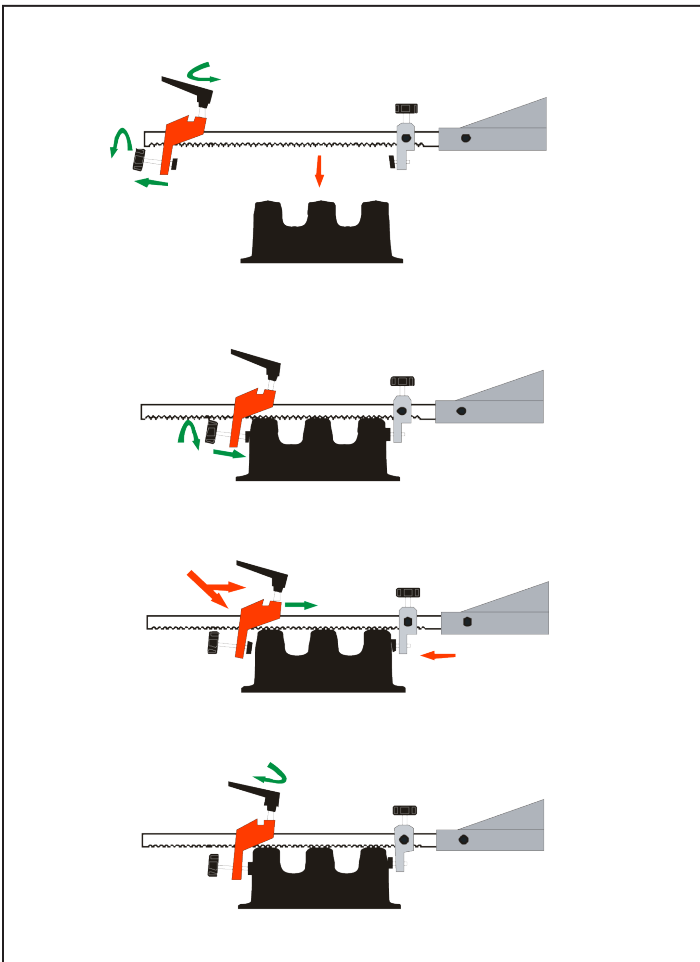

CONNECTING THE WIRE FEED/ WELDING TIP TO THE RW30

1. Place the welding tip into the support.

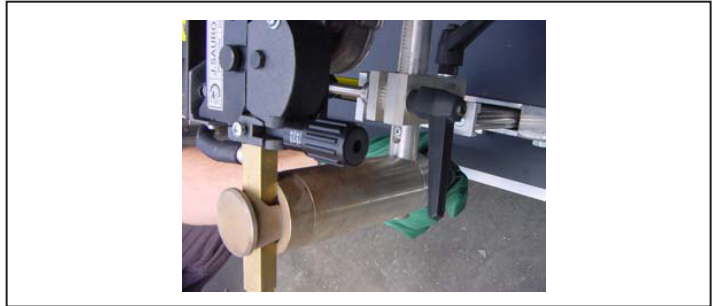

2. Support swivel blocking lever.

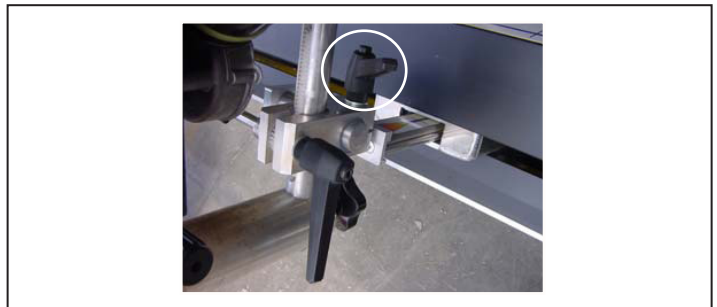

3. Support stick-out lever.

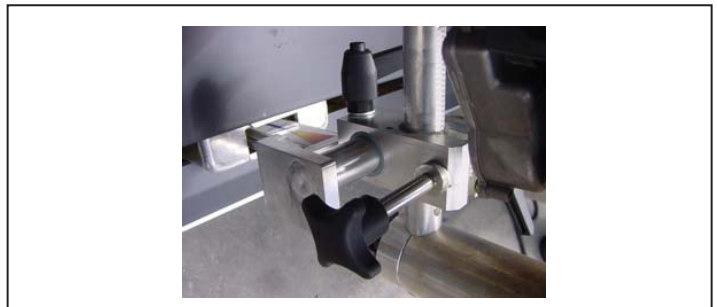

SETTING THE STICK OUT

The ideal setting is 30 mm. Use the template markers to check for proper distance.

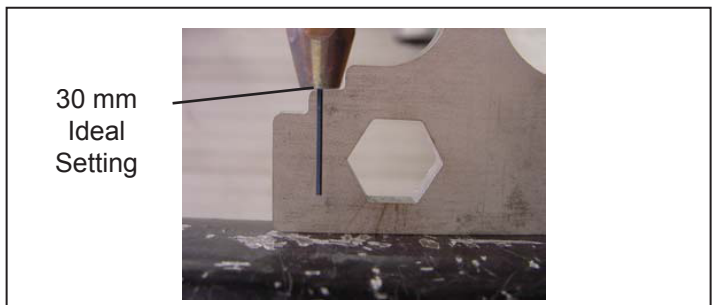

OPERATION

OPERATING THE RW30 & THE CHARLIE CONTROL UNIT

1. Turn ON the main switch on the RW30.
2. Unlock the ON/OFF switch on the Charlie Control Unit located on the right side of the unit.

AUTOMATIC TRACK MODE

After preheating, this mode is used on carbon steel track for continuous surface work on three or four-sided octagonal polygons.

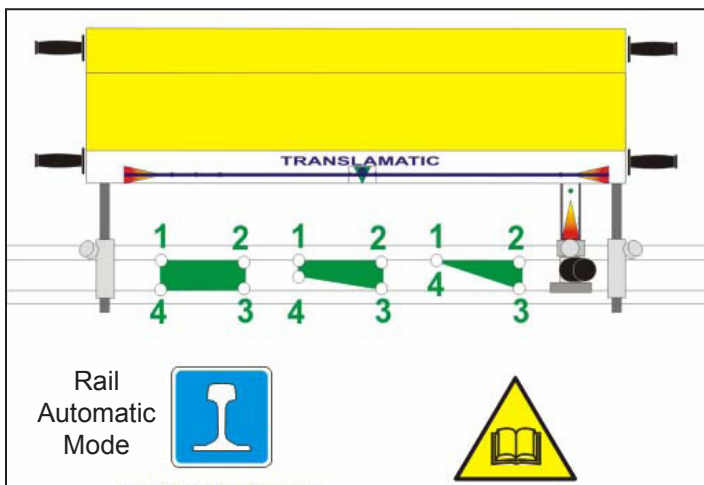

AUTOMATIC POINTS/FROG MODE

With no preheating, this mode is used on manganese steel points and frogs. For strip-by-strip work alternately of 1 to 3 three or four-sided polygonal surfaces.

After preheating, this mode is used on carbon steel points or frogs for continuous surface work on three or four-sided polygons.

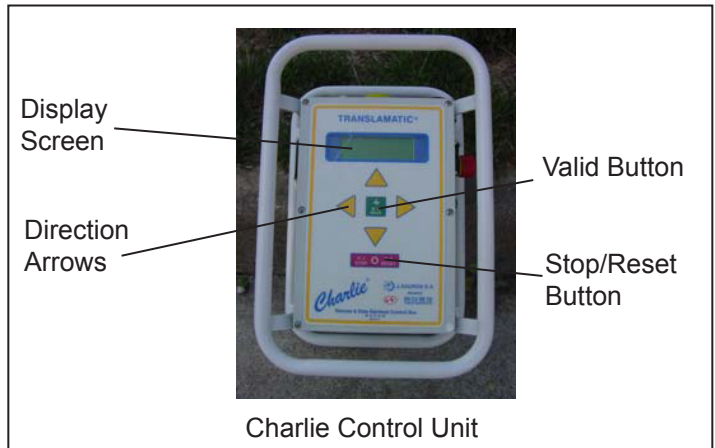
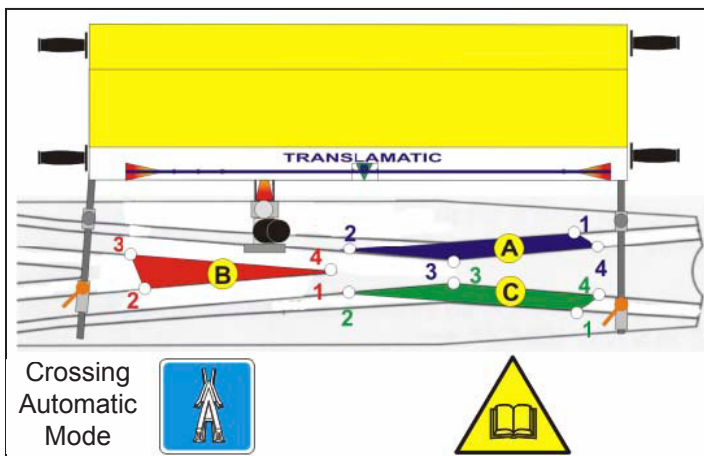

A computerised control unit to command the welding cycle, Charlie® is presented in a polycarbonate-housing unit equipped with a liquid crystal display and a six-keypad keyboard under lexan for man-machine dialog. Its 5 metre shielded mains cord can be wrapped around its tubular-shaped chassis.

The Charlie® control unit is adapted for on-site work. Its protection rating classifies it for uses under all weather conditions.

THE “CHARLIE” CONTROL UNIT CONTROLS

The SCREEN displays messages as well as tracing information for the user.

The VALID is used to validate the current step. During a cycle, it is used to display the welding U and I.

The STOP button is used to return to the previous step. During a cycle, it is used to momentarily or definitively stop the welding cycle.

The UP and DOWN arrows are used to scroll through the alphanumeric character list during the tracing data acquisition stage. In the setting stage, it is used to move the head along the Y-axis.

The LEFT and RIGHT arrows are used to scroll through the alphanumeric character list during the tracing data acquisition stage. In the setting stage, it is used to move the head along the X-axis.

OPERATION

Below are screen examples of scrolling through the alphanumeric character list.

In tracing mode

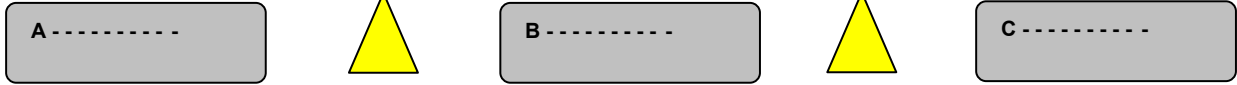

Examples: scrolling up the list



Examples: scrolling down the list

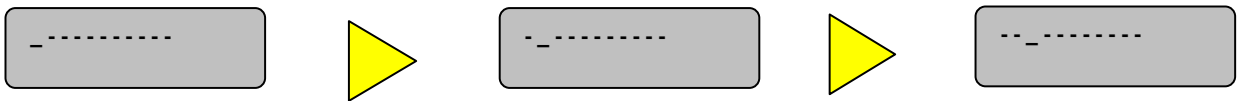

Examples: moving the cursor from left to right



Examples: moving the cursor from right to left

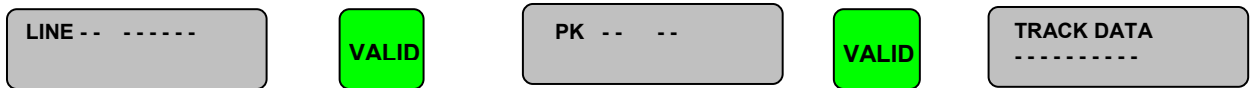

Examples: moving forward through the operator dialogue

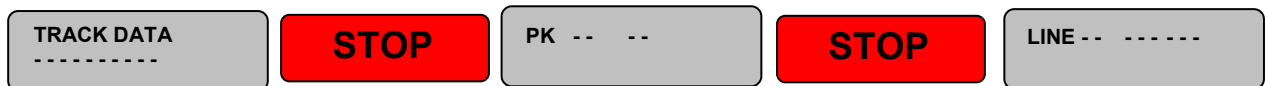

Examples : moving back through the operator dialogue

In welding mode

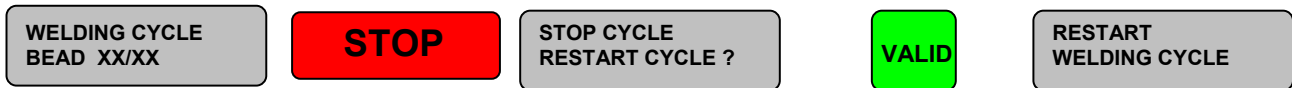

Example: momentary stop in the welding cycle



Example: definitive stop in the welding cycle

OPERATION

LANGUAGE SETTING

Different languages may be accessed and selected when the first message "HELLO" appears by using the PLUS key. Translations of the message "HELLO" into different languages according to geographic areas are then displayed each time the PLUS key is pressed.

SETTING THE DATE AND TIME

To set the date and time, scroll until "DATE AND TIME" is displayed. Set the date and time by pressing the PLUS or MINUS keys. Confirm using the VALID key.

Depending on how the unit is configured, the "DATE TIME" message may not be displayed if the most succinct level of operator dialogue is used.

PRINTING DATA

To print the data stored in memory:

1. Make sure that the unit is connected to a power source.
2. Connect either a serial printer (9-pin connector) or a parallel printer if the unit is equipped with a parallel interface (25-pin connector).

When using a serial printer, make sure:

1. that the serial printer communication parameters are set correctly:
 - 9600 bauds
 - no parity
 - 8 data bits
 - 1 stop bit
 2. that the correct serial cable is used.
3. Make sure the printer is ONLINE and READY.
 4. Turn on the unit and scroll to the IMPRESSION step, available by the automatic detection by the system of the presence of a printer.
 5. Select the output mode:
 - Welding number
 - Operator ID
 - Date
 - All

6. Confirm choice using the VALID key.

INFORMATION ON DATA TRACKING

MANUAL DATA ENTRY

Some areas may require manual data entry:

- Operator stamp
- Location, district code, line, mileage point, track and rail line
- Type of metal deposition
- Type of power source
- Type of rail
- Type of resurfacing.

Two types of manual entries are possible:

1. Character by character mode.

Pressing the PLUS or MINUS keys causes the allowable characters to be displayed each character is confirmed by the VALID key.

2. Pre-programmed values.

Pressing the PLUS or MINUS keys causes the various pre-programmed values to be displayed. Each value is then confirmed by pressing the VALID key. When the characters "----" appear, this indicates characters available for manual character-by-character entry.

AUTOMATIC DATA ENTRY

Data can also be acquired by reading bar codes.

Depending on the software installed in the unit and according to the user companies' specifications, data may be acquired automatically. Depending on these specifications, data may be required or optional.

The software includes a standard operator description card with a 30-digit ISO bar code.



OPERATION

OPERATOR DIALOGUE

Power up:

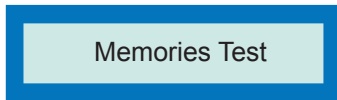

Then:

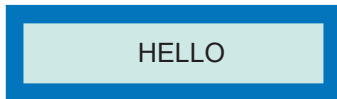

Change language - press the arrows:

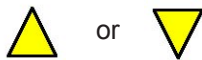

Display software version and Charlie serial number.

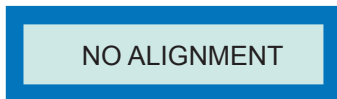

This mode allows to perform free polygons from 3 to 4 sides.

- Setting the points without restriction (beads direction : Position O1 to Position O2).
- When setting the 4 points, point 4 can be out of the vertical alignment of point Position O1; without automatic control of any alignment.
- Welding mode « bead by bead ».



Simple welding mode: Shapes like rectangle, triangle and butt welding.

- Non stop welding our bead by bead.
- Realization with or without surrounding.

Changing welding modes by pressing:

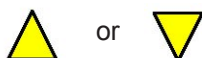

Validate by pressing:



Corrections can be made by pressing:



! Note: This is also effective during all welding cycle. To go to the next step, press:



To step back to the previous step, press:

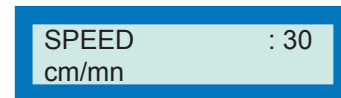

Welding speed displayed cm/min (1 cm/min equals to 0.4 inch/min) (adjustable value in the parameter menu).



Allow to move the torch according into 2 axis « X » et « Z ».

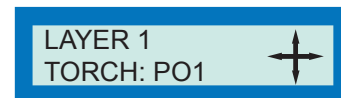

Set point Position O1. Define the resurfacing area.

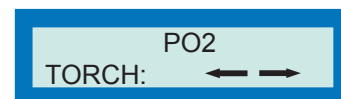

Set point Position O2. The torch cans only moves on the « X » axis.

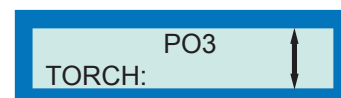

OPERATION

Set point Position O3. The torch can only moves on the « Z » axis.

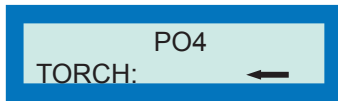

or

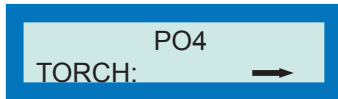

or

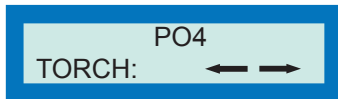

Set point Position O4. This point should only be set vertically from point Position O1 with automatic tone of this position.

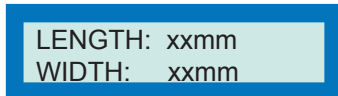

Display the length and the width of the setting shape (1 mm equals to 0.04 inch).



Surrounding selection: « YES », or « NO », (continuing bead from Position O1 to Position O2 then to Position O3 then to Position O4 and finally to Position O1).

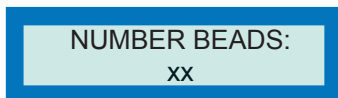

Display the number of beads that will be made during the resurfacing (the surrounding is not included in this number). It is possible to modify this number if needed by pressing:

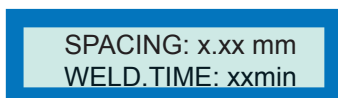
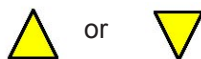

Display of the step between each bead, (distance in mm, 1 mm equals to 0.04 inch) and estimate welding time in minutes.

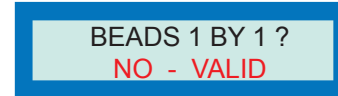

Welding mode choice: bead by bead, « YES », or continue, « NO ».

If « YES », welding bead by bead (Torch is moving at the beginning of the next bead right after previous bead is done).

If « NO », beads are done in “continue”.



If VALID key is pressed, Torch will move to starting point of Position O1. Welding will start.

While welding:



Torch moves to starting point of the welding or at the beginning of the new bead if “bead by bead” mode has been selected.



Surrounding welding if that option has been selected.

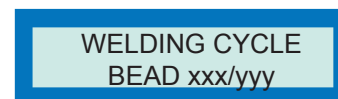

Shows the bead’s number in welding, « xxx », and the total number of beads of the whole resurfacing of the area, «yyy».

If « bead by bead » option is selected, the following screen appears at the end of the previous bead and after the torch is set.

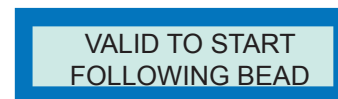

OPERATION

If VALID key is pressed, torch will move to the starting point of the next bead.

RETURN TORCH TO
INITIAL POINT

Torch return to starting point and start welding of the next bead.

END LAYER N : 1
LAYER N : 2 - VAL

When resurfacing is over, the following message proposes to set a new resurfacing cycle:

If VALID key is pressed, you will have to set a new welding area. (As previously seen).

If RESET key is pressed:

NEUTRAL POINT ?
TRANSPORT - VALID

Allow to place the torch in « Parking » position.

If VALID key is pressed, torch will move to « Parking » position.

If RESET key is pressed, back to message:

HELLO

NO ALIGNMENT

 Note: This is also effective during all welding cycle.

To go to the next step press the VALID key.

To step back to the previous, press the RESET key.

SPEED : 30
cm/mn

Welding speed displayed cm/min (1 cm/min equals to 0.4 inch/min) (adjustable value in the parameter menu).

RETRACTING
POINT



Selection of Torch position after the welding of each bead (evacuation point).

The setting is done as:

PO1
TORCH:



Set point position O1.

PO2
TORCH:



Set point position O2.

PO3
TORCH:



Set point position O3.

TRIANGLE ?
NO - VALID

or

TRIANGLE ?
YES - VALID

Triangle can be weld: if « NO », set point Position O4. If « YES », needed number of beads will be display.

PO4
TORCH:



Set point position O4.

NUMBER BEADS:
XX

Display the number of beads that will be made during the resurfacing (the surrounding is not included in this number). It is possible to modify this number if needed by pressing:

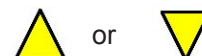

OPERATION

SPACING : x.xx mm
WELD.TIME : xxmin

Display of the step between each bead, (distance in mm, 1 mm equals to 0.04 inch) and estimate welding time in minutes.

-Setting can be made up to 3 shapes:

SETTING SHAPE X ?
NO - VALID

SETTING SHAPE X ?
YES - VALID

Option to repeat the same shape or change the size and shape as previously indicated.

During welding:

RETURN TORCH TO
INITIAL POINT

Torch moves to starting point of the first bead.

WELDING CYCLE
BEAD xxx/yyy

Shows the bead's number in welding, « xxx », and the total number of beads of the whole resurfacing of the area, «yyy».

MOVE TORCH

Torch will moves to retracting point after bead.

VALID TO START
FOLLOWING BEAD

Press VALID key to start the next bead.

END LAYER N : 1
LAYER N : 2 - VAL

If VALID key is pressed, you will have to set anew welding area. (As previously seen).

If RESET key is pressed:

NEUTRAL POINT ?
TRANSPORT - VALID

Allow to place the torch in « Parking » position.

If VALID key is pressed, torch will move to « Parking » position.

If RESET key is pressed, back to message:

HELLO

STOP AND RESTART OF WELDING CYCLE

During the welding, in whatever mode you have selected, stopping the welding cycle is always possible:

Pressing the RESET key will stop the weld cycle.

STOP CYCLE
RESTART CYCLE ?

To restart the welding cycle, press VALID key.

According to what mode you are using, a correction of the exact positioning of the torch during the stopping can be done:

-Maximum correction: 1 cm following the 2 axis « X » and « Z »

To stop the welding cycle, press the RESET key.

ERROR MESSAGES

During the setting of the points, some errors message can appear:

Set Position O2:

MIN LEN : 30mm !
LENGTH : xx mm

The distance between points Position O1 and Position O2 must be minimum or equal to 30mm on « X » axis. (This message will be displayed only if the distance between Position O1 and Position O2 < 30mm). Note : this distance (30mm equals to 1.18 inch) is set in the parameters menu.

OPERATION

Set Position O4:

-In mode « ALIGNMENT OK »

UNVALID POINT
RETURN TO PO1

Position O4 must be vertical from Position O1.

When the beads number has been modified:

ERROR !!!
SPACING > xx.x mm

The step is bigger than the maximum allowed step. Raise the number of beads.

ERROR !!!
SPACING < xx.x mm

The step is smaller than the minimal allowed step. Reduce the number of beads.

These 2 values can be modified in the parameters menu.

ERROR
BEADS NUMBER > 3

The number of beads must be superior at 3.

DIV ERROR

Show an inappropriate calculation not allow by the software.

TROUBLESHOOTING

<i>The « ON » TRANSLAMATIC's green light does not work</i>	
PROBABLE CAUSE	CHECKS AND REMEDYS
« ON/OFF » switch	Check its good position and its good working order
Alimentation's cable cutted	Check the alimentation's cable
Alimentation's plug	Check the alimentation's plug
Alimentation's fuse or circuit breaker	Check the primary alimentation
<i>The « ON » TRANSLAMATIC's green light works but the Charlie box does not work</i>	
PROBABLE CAUSE	CHECKS AND REMEDYS
Link cable between the TRANSLAMATIC and the Charlie box	Check the connexions or/and change the cable
Charlie box's fuse	Check the fuse
Respect the « ON » process order	Put « ON » the Translamatic before putting the Charlie box "ON".
Charlie box	Try with another Charlie box
Interface card	Check if the interface card alimentation's green light is alight during the cycle. Call our After Sales Dpt
Stabilized alimentation out of service	Check the alimentation's tension, normally 27V in CC. Call our After Sales Dpt
<i>The welding support head does not move on one or several axis</i>	
PROBABLE CAUSE	CHECKS AND REMEDYS
Charlie box	Try with another Charlie box
Charlie box keyboard	Check the good working order of the keyboard's contacts. Check the good working order of the keyboard using it in the test mode for example. Call our After Sales Dpt
Interface card	Check the connexions Check if the card's lights are alight during a moving command. Call our After Sales Dpt
Axis engine's cards	Check if the card's lights are alight during a moving command. Switch the connexions between the 2 engines and the recheck the moving of the torch (the movements are reversed) Call our After Sales Dpt
Translation's screw mechanically blocked	Check if the screw is not top-blocked on the stop bumpers or on the ball bearing or on the cardan. Unscrew manually the screw if it is possible. Call our After Sales Dpt
<i>Uncontrolled speed of the torch and/or no high speed and/or speed not as usual.</i>	
PROBABLE CAUSE	CHECKS AND REMEDYS
Charlie box	Try with another Charlie box Change the Charlie box card

TROUBLESHOOTING

Coder's pulses defect	Check the coder connexion on the right side and on the bottom of the interface card (J3 connector side). Replace the interface card.
Axis engine's cards	Check if the card's lights are alight during a moving command. Switch the connexions between the 2 engines and the recheck the moving of the torch (the movements are reversed) Call our After Sales Dpt
Interface card	Check all the connexions Check if the card's lights are alight during a moving command. Replace the interface card Call our After Sales Dpt
Couple Engine + Coder.	Replace the couple Engine + Coder.
<i>No wire feeding</i>	
PROBABLE CAUSE	CHECKS AND REMEDYS
The PGA	Close or set up the wire's pressure with the PGA's rollers.
The Roll n' Roll	Check the wire's drum and/or set the Roll n' Roll brake
Cables	Check the connexions and the PGA's alimentation cable
Charlie box	Try with another Charlie box Check if the welding command light is alight on the interface card
Link cable between the TRANSLAMATIC and the Charlie box	Check the connexions or/and change the cable
Welding trigger opened (Welding control connector)	Check the closing of the welding trigger with an ohmeter (value < to 20 ohms) between the pins 3 and 4 of the 7 points connector or C and D of the Amphenol connector 19 points.
Stabilized alimentation out of service	Check the alimentation's tension, normally 27V in CC. Call our After Sales Dpt
<i>Wire feeding OK but no welding</i>	
PROBABLE CAUSE	CHECKS AND REMEDYS
Ground cable	Make sure that the ground cable is well connected
Interface card	Check if the card's lights are alight during a moving command. Call our After Sales Dpt
Arc welder generator	Check the parameters and the good operating of the arc welder Call our After Sales Dpt

SPECIFICATIONS

RW30110 / RW30112

Power	115V, 60Hz, 175W
X Axis Movement.....	400 mm / 15.7 in.
Y Axis Movement.....	350 mm / 13.7 in.
Length.....	925 mm / 36.4 in.
Width	650 mm / 25.5 in.
Height.....	440 mm / 17.3 in.
Weight	25 kg / 55 lbs
Charlie Control Box Weight (with 5m of cable).....	3 kg / 6.6 lbs
Pull Gun Weight (without wire reel)	12 kg / 26.4 lbs

RW30120

Power	230V, 60Hz, 150W
X Axis Movement.....	1250 mm / 49.2 in.
Y Axis Movement.....	350 mm / 13.7 in.
Length.....	1510 mm / 59.4 in.
Width	830 mm / 32.6 in.
Height.....	430 mm / 16.9 in.
Weight	34 kg / 74.9 lbs
Charlie Control Box Weight (with 5m of cable).....	3 kg / 6.6 lbs
Pull Gun Weight (without wire reel)	17 kg / 37.4 lbs

NOTICE

In addition to the Safety Precautions in this manual, observe the following for equipment protection and care.

- Check that the pin holder is not burnt or not holding the pin tightly. If not, remove the ring holder, clean all the parts and squeeze the fingers of the pin holder together.
- Check the cables on the gun from time to time for damage. Replace as required.
- Check that the lift level is correct with lift level tool.
- Always store the tool in a clean dry space, safe from damage or pilferage.
- Always keep critical equipment markings, such as warning stickers and tags legible.
- Equipment repair should be performed by experienced personnel only.
- Do not use the equipment for applications for which it was not intended.

RW30 HEATER INSTALLED 2009 OR EARLIER



Front Cover

Back Cover

Heater Element Thermostat



Charlie Heater 70722

RW30 COLD WEATHER UPDATE KIT (70716) INCLUDES THE FOLLOWING

Part No.	Description
70719	Heater Element (110 V, 400 W)
70720	Thermostat (Red)
70718	Back Cover
70717	Front Cover
70721	Screw Kit
70722	Charlie Heater Kit
70723	Butt End Flask
71000	Thermostat (Blue)

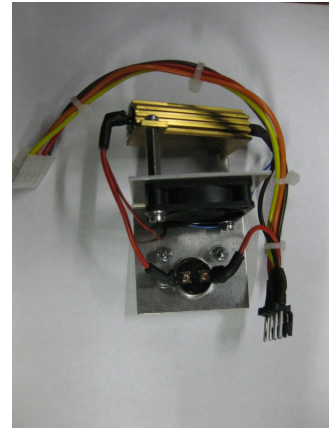

Heater Element

Thermostats (Red & Blue)

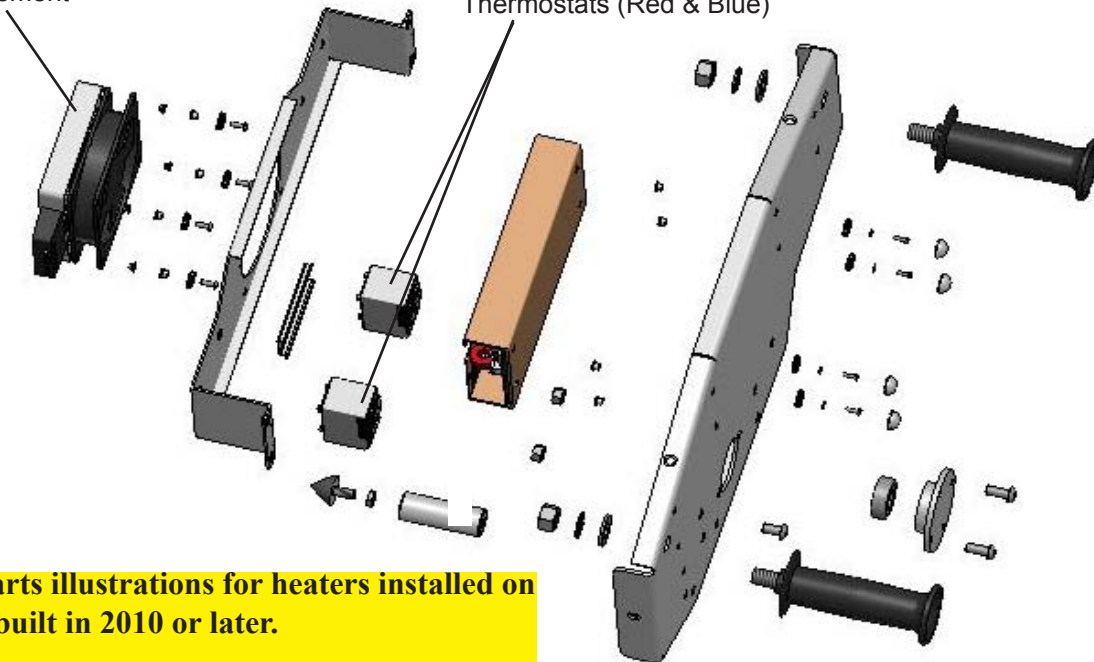

See parts illustrations for heaters installed on units built in 2010 or later.

ACCESSORIES & PARTS

Part No.	Description
52736	Cable - Welder, Robotic
52737	Kit - Track Wheel, Robotic
52738	Kit - Track Wheel Welder, Robotic
52739	Wire - Coated Weld Std Rail
52740	Wire - Coated Weld Mn Rail
52741	Box - Transport
60872	15m Ground Cable
60875	Ground Clamp for Frog
60876	Ground Clamp for Rail
60822	Cable, Generator 15M Long (Europe)
60823	Cable, Generator 15M Long (Miller)
60824	Transport Box RW20110, USA
60825	Transport Box RW20120, USA
60826	Tracability Kit
62328	Carbon Frog Insert
62350	Angle Attachment
62386	1/16 in. / 1.6 mm Frog Build Wire
62387	1/16 in. / 1.6 mm Rail Build Wire
65439	Welding Cable (Negative 15 M)
65441	Welding Cable (Positive 15 M)
67090	Pre-Heater (Carbon Steel Frogs)
69835	PGA Power Supply Cable (Pull Gun)
69833	Lincoln (HD), Wire Feed Cable
69836	Screen for Charlie
65443	Pull Gun Head
65444	Torch 4 M
65447	Kit
65449	Stick Out Gauge
65450	Serial & Parallel Option
65451	Stick Holder
65452	Rotary Head Kit
65453	Pre-Heater Ramp
65457	Welding Current Kit
66642	Pull Gun
66643	Inverter
66644	Torch
66766	Tool Case (with Tools)
66767	Glasses
66768	Mask, Automatic Darkening
66769	Mask, Manual
69889	Charlie Main Board
66773	Cable, 10 M (Generator to Robot)
67090	Pre-Heater (Carbon Steel Frogs)

Part No.	Description
69823	Roll Un Roll Drum Holder
69824	Blue bag for Charlie
69827	Male base, 6 P + gnd (wire feeder electrical conn)
69828	Plug for Male Base (Protective)
69832	Male base, 3 P + gnd (power cord)
69822	Adaption Box
73637	Charlie Lexan Keypad cover (Note: this is the overlay only for the control box with led screen and push pad, not the entire box)
73307	Push pin for clamp
	
73314	Option Roll for 2.0mm Welding Wire

Part No.	Description
Cables - RW30110BN Only	
68208	Charlie to Robot Cable (All Models)
68209	Power Cable (RW30110BN Only)
68210	Wire Feed Cable (Miller, Lincoln) (RW30110BN Only)
68211	Wire Feed Cable (0X0) (RW30110BN Only)
RW30110 / RW30112 / RW30120 Models Only	
65445	Wire Feed Cable
65442	Power Cable without End Plug
68208	Charlie to Robot Cable

SPARE PARTS

Trigger Cord 70780



Power Cord Primary 70781



Rack 66551
(Includes Pinion Below)



Pinion 66551
(Includes Rack above)



Motor/Board Cable 70786



PGA Cable 70787



Charlie Cable 68208



Power Supply Cord 70785
Y axis



Power Supply Cord 70784
X Axis



Power Supply Cord 70783
Internal



Charlie Box 65446



Charlie Main Board 69889



Interconnection Board 64969

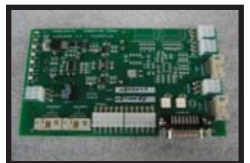

Motor Board 64961



Power Supply 69830



No/Off Switch 69831



Motor X 64963



Motor Y 64962



Power Cord LED 70782



Charlie Box Fuse 70774



SPARE PARTS

Bearing Y Axis 66533



Bearing X Axis 64950



Nut 66529



Beam, Souriau 70779



Pad Clamp 70775



Coupling, Y Axis 66535



Power Cable (115V) 68209



Male Crosspin Knob M10-45
73158

No Photo

TEMPLATE GAUGE



Template gauge for setting the stick height (see page 13).

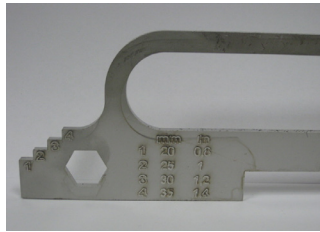

Template gauge with 4 height settings indicated in millimeters and inches.



Removing wire feed tip using hex in template gauge.

MASTER POWER SWITCH 2009 OR EARLIER



Master Power Switch Off



Master Power Switch On, this picture indicates the fan is on but the outside ambient temperature is below $-10^{\circ}\text{C}/14^{\circ}\text{F}$, allow the unit to warm-up until the left power light comes on indicating the unit is safe to use. Do not operate the unit when the left power light is off with the power switch turned on.



Master Power Switch and Fan On.

MASTER POWER SWITCH 2010 OR LATER



Master Switch OFF



Power is On Heater Activated



Unit On Heater Activated



Unit On Heater Off

RW30110 / RW30112 PARTS LIST & ILLUSTRATION

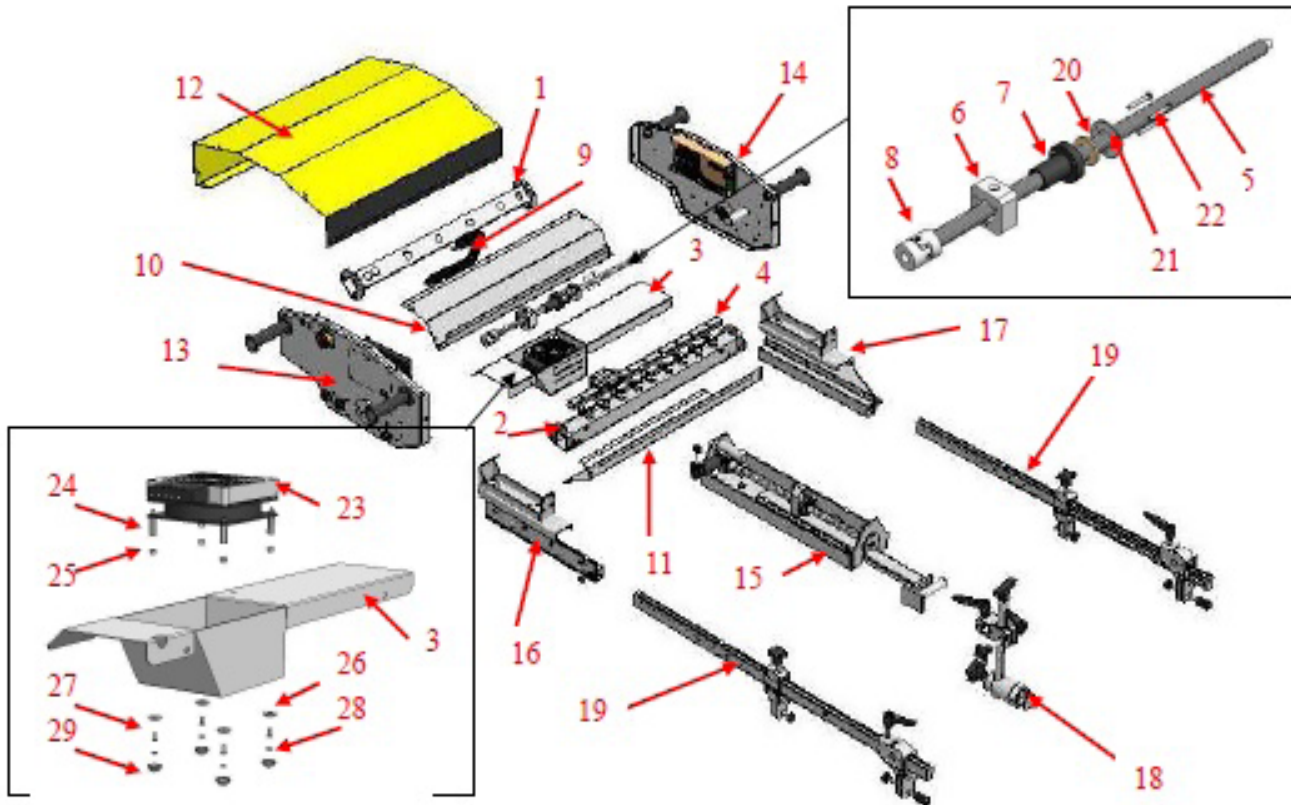

Item	Part No.	Qty	Description
1	64983	1	Rear Beam
2	64984	1	Front Beam
3	71473	1	Ventilation Box
4	66530	1	X-Axis Slide
5	66526	1	X-Axis Screw
6	---	--	---
7	66529	1	Nut
8	66535	1	Coupling Y-Axis
9	66536	1	Chain Conduit
	66537	1	Clamp for Chain Conduite (not show)
10	70718	1	Back Cover
11	70717	1	Front Cover

Item	Part No.	Qty	Description
12	64988	1	Cover
13	69818	1	Left Side Assembly
14	69819	1	Right Side Assembly
15	69816	1	Support Platform Assembly
16	66543	1	Left Support
17	66542	1	Right Support
18	69815	1	Torch Support Assembly
19	66546	2	Frog clamp Assy
20	----	--	-----
21	----	--	-----
22	----	--	-----
23	70719	1	Heater Element
24	----	--	-----
25	----	--	-----
26	----	--	-----
27	----	--	-----
28	----	--	-----
29	----	--	-----

RW30120 PARTS LIST & ILLUSTRATION

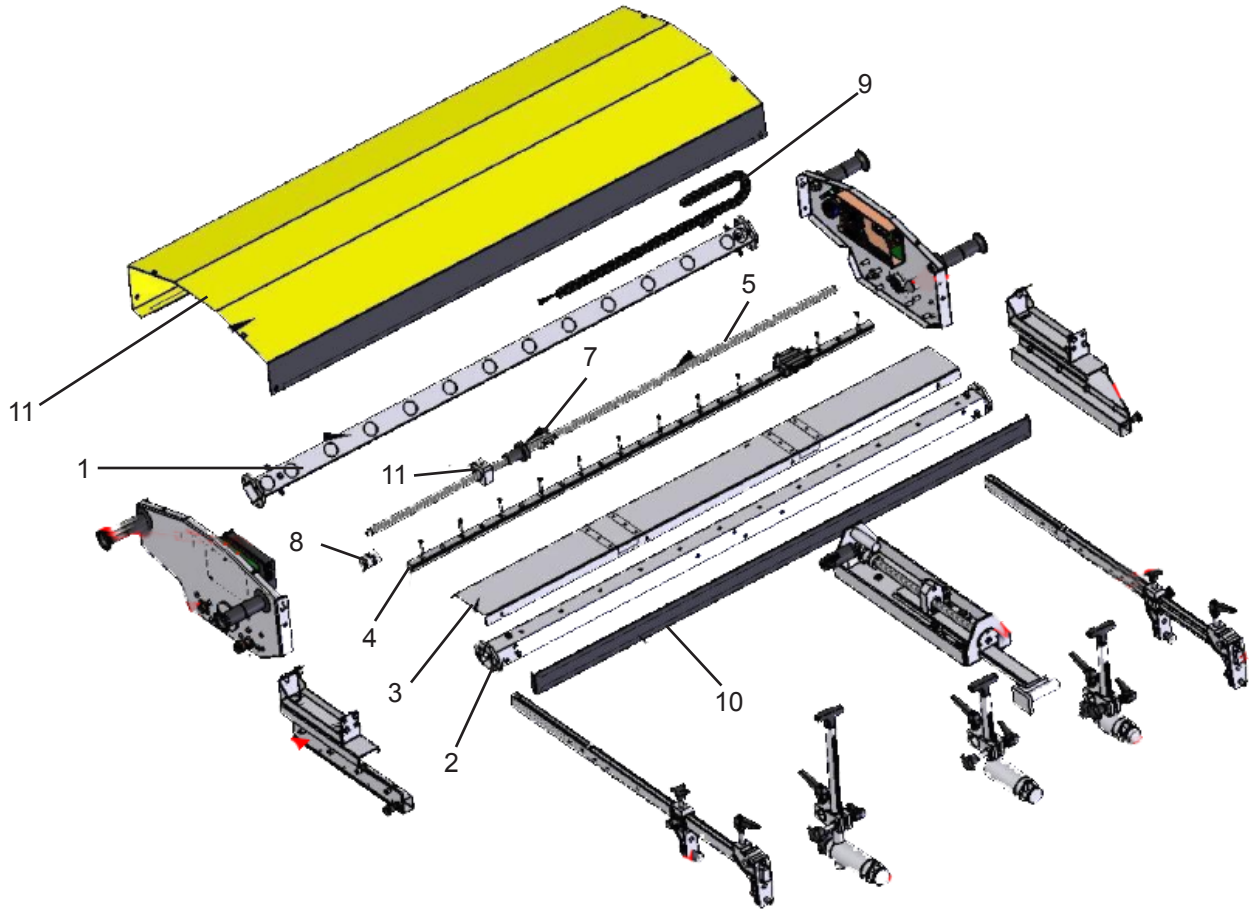

Item	Part No.	Qty	Description
1	66515	1	Rear Beam
2	66519	1	Front Beam
3	66517	1	Protection Plate
4	66531	1	X-Axis Slide
5	66528	1	X-Axis Screw
6	---	--	---
7	66529	1	Nut
8	66535	1	Coupling Y-Axis
9	66536	1	Chain Conduit
10	66537	1	Clamp for Chain Conduit (not show)
11	66554	1	Hood 1252

RW30110 / RW30112 / RW30120 LEFT SIDE ILLUSTRATION

Left Side Assembly
Part No. 69818

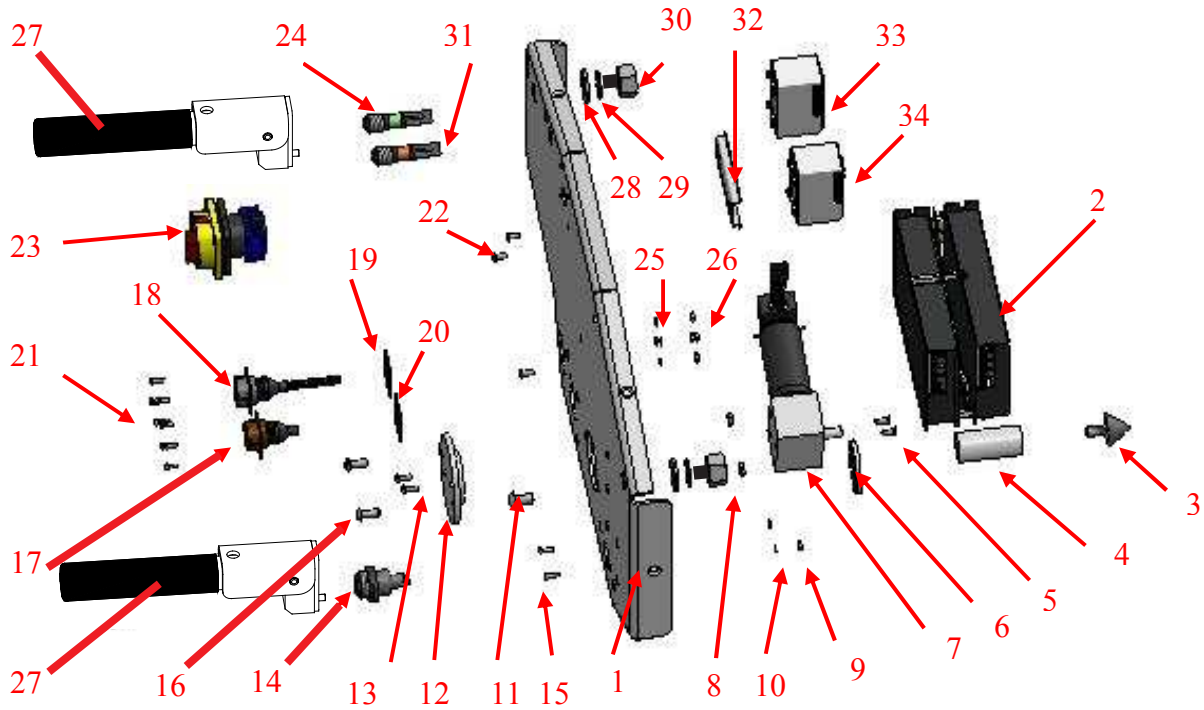

Item	Part No.	Qty	Description
1	66524	1	Left Side Plate (Motor)
2	69817	1	Motor Card Module
3	64945	1	Conical Stop
4			
5			
6	64959	1	Bearing Flange
7	64963	1	Motor X Axis
8			
9			
10			
11			
12	64957	1	Motor Support
13			
14			
15			

Item	Part No.	Qty	Description
16			
17	69826	1	Charlie box take off
18			
19			
20			
21			
22			
23	69831	1	Power On/Off Switch
24			
25			
26			
27	72593	2	Carry Handle Assy (Fold Down)
28			
29			
30			
31			
32			
33	70720	1	Thermostat (Red)
34	71000	1	Thermostat (Blue)

RW30110 / RW30112 / RW30120 RIGHT SIDE ILLUSTRATION

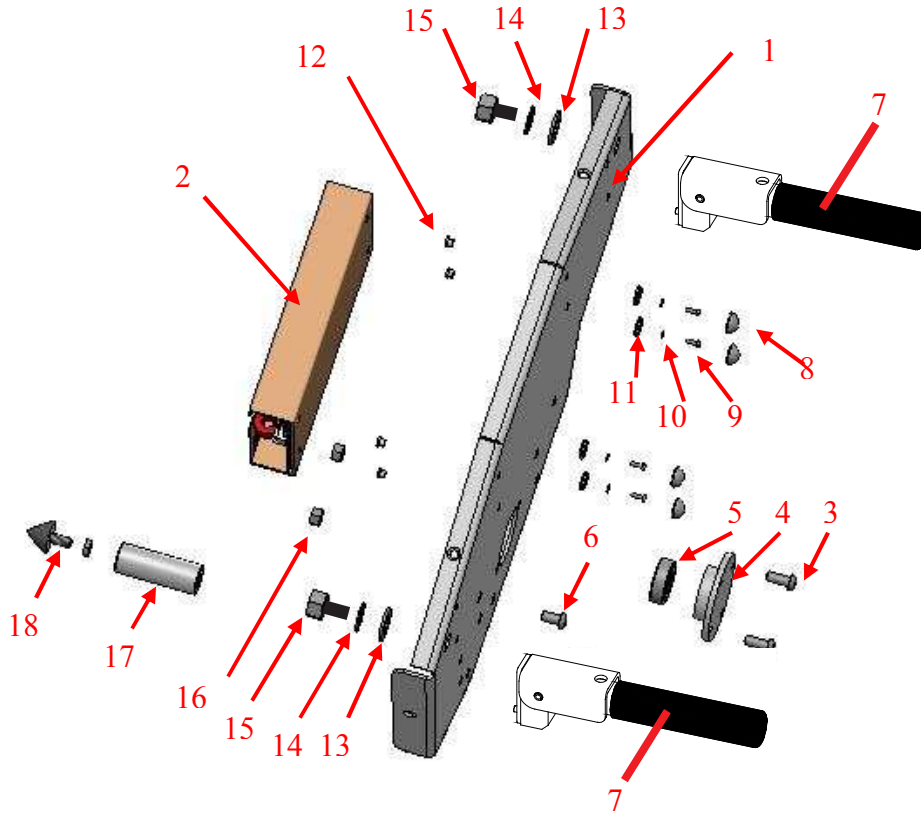

Right Side Assembly
Part No. 69819

Item	Part No.	Qty	Description
1	66525	1	Right Side Plate
2	69830	1	Power Supply
3			
4	64956	1	Bearing Support
5	64955	1	Bearing
6			
7	72593	2	Carry Handle Assy (Fold Down)
8			
9			
10			
11			
12			
13			
14			
15			
16			
17			
18	64945	1	Conical Stop

RW30110 / RW30112 / RW30120 MOTOR BOARD

Motor Board Assembly
Part No. 69817

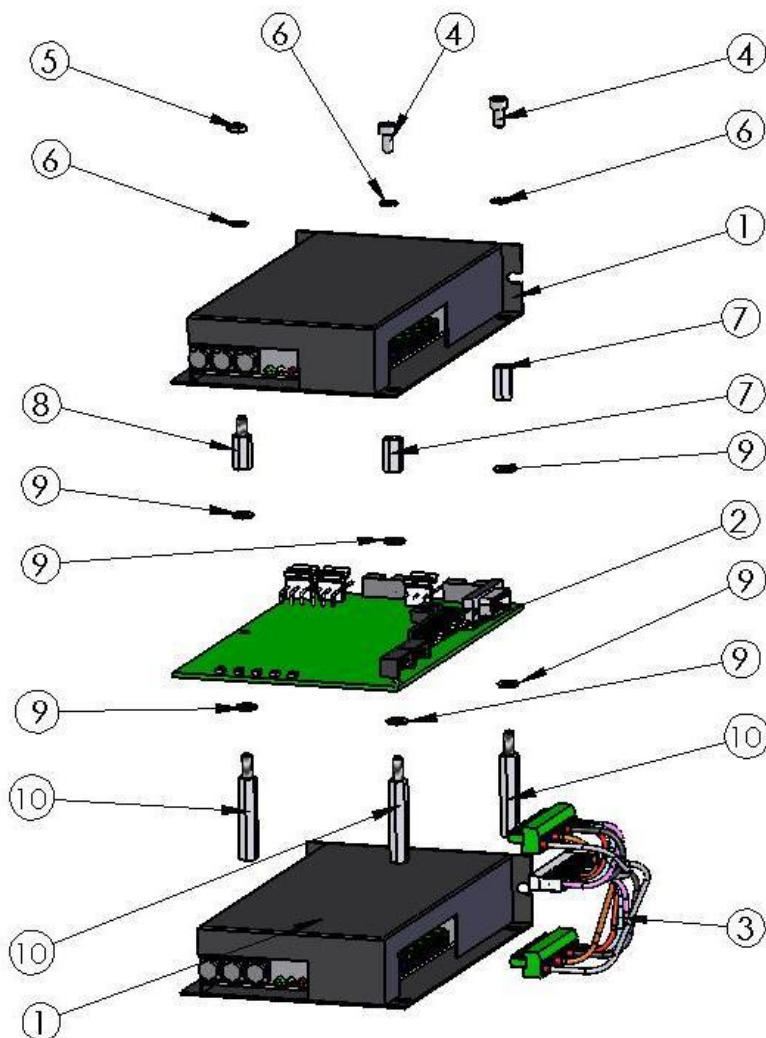

Item	Part No.	Qty	Description
1	64961	2	Motor Board
2	64969	1	Interconnection Board

RW30110 / RW30112 / RW30120 SUPPORT PLATFORM

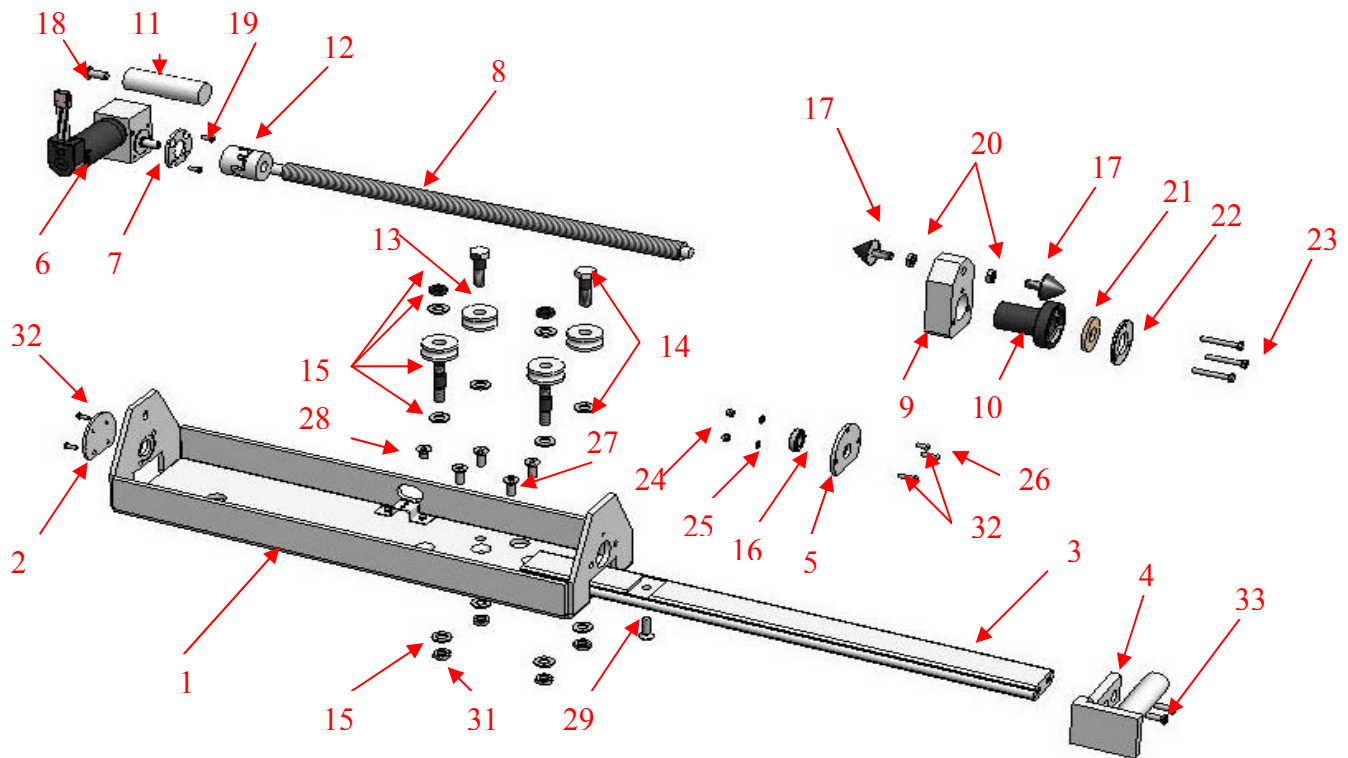

Item	Part No.	Qty	Description
1	64986	1	Support Platform
2	---	--	----
3	64985	1	Y-Rail
4	66549	1	Jointed Wrist Bracket
5	66532	1	Bearing Support
6	64962	1	Y-Axis Motor
7	64959	1	Bearing Flange
8	66534	1	Y-Axis Screw
9	64958	1	Axis Bracket
10	66529	1	Nut
11	66538	1	Y-Bump Stop
12	66535	1	Coupling Y-Axis
13	64948	4	Steel Roller
14	64949	2	Axle
15	64950	2	Ecentric Axle
16	66533	1	Bearing
17	64945	2	Conical Stop
33	69834	2	Screw FHC

Support Platform Assembly
Part No. 69816

RW30110 / RW30112 / RW30120 SUPPORT ASSEMBLY

Right Support Assembly
Part No. 66542

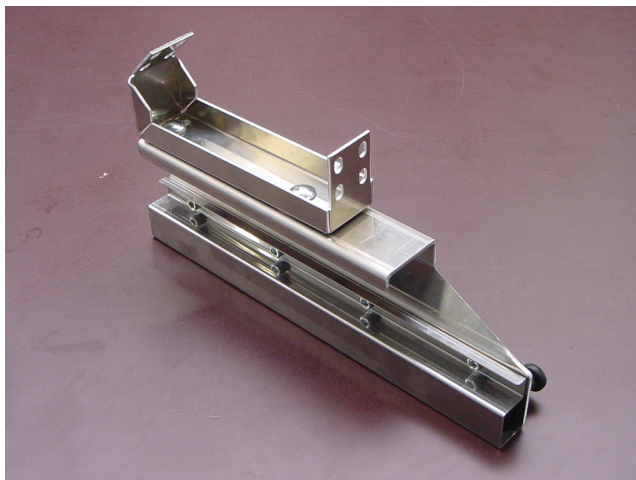

Left Support Assembly
Part No. 66543

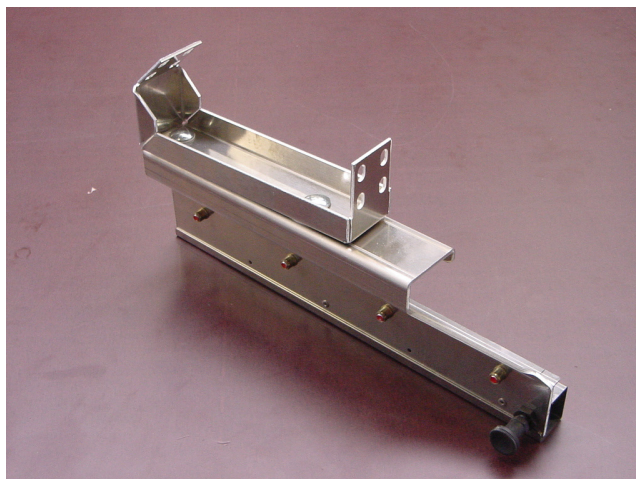

Charlie Heater
Part No. 70722

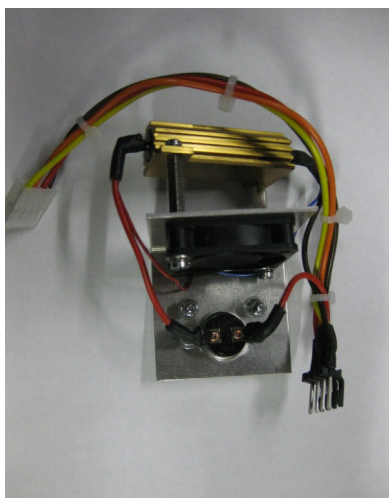

Charlie Control Box
Part No. 65446



CLAMP ASSEMBLY

Frog Clamp Assembly
Part No. 66546



Right Fixed Clamp
Part No. 66547



Left Pivot Clamp
Part No. 66548

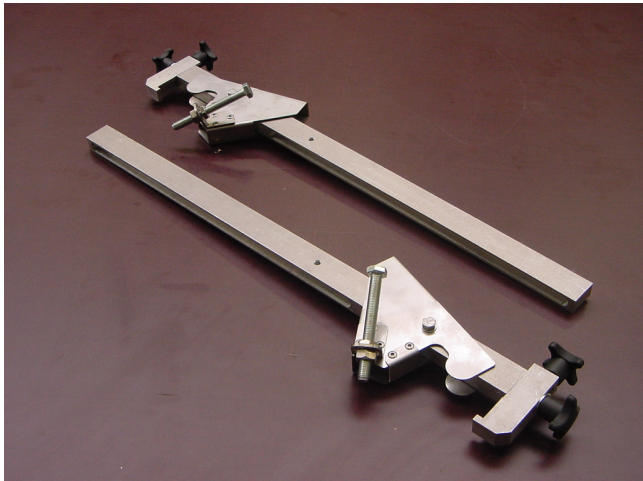
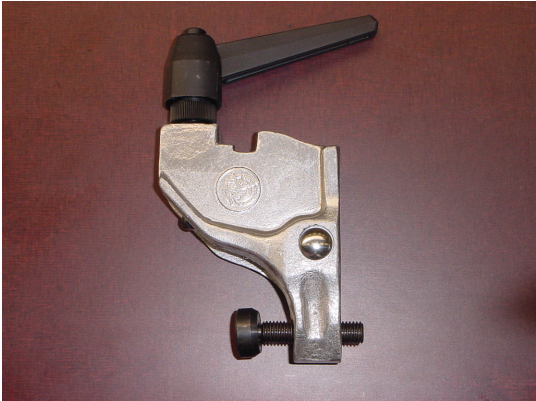

Right Self Alignment Clamp
Part No. 66544

Left Self Alignment Clamp
Part No. 66545

TORCH SUPPORT PARTS LIST & ILLUSTRATION

Torch Support Assembly
Part No. 69815

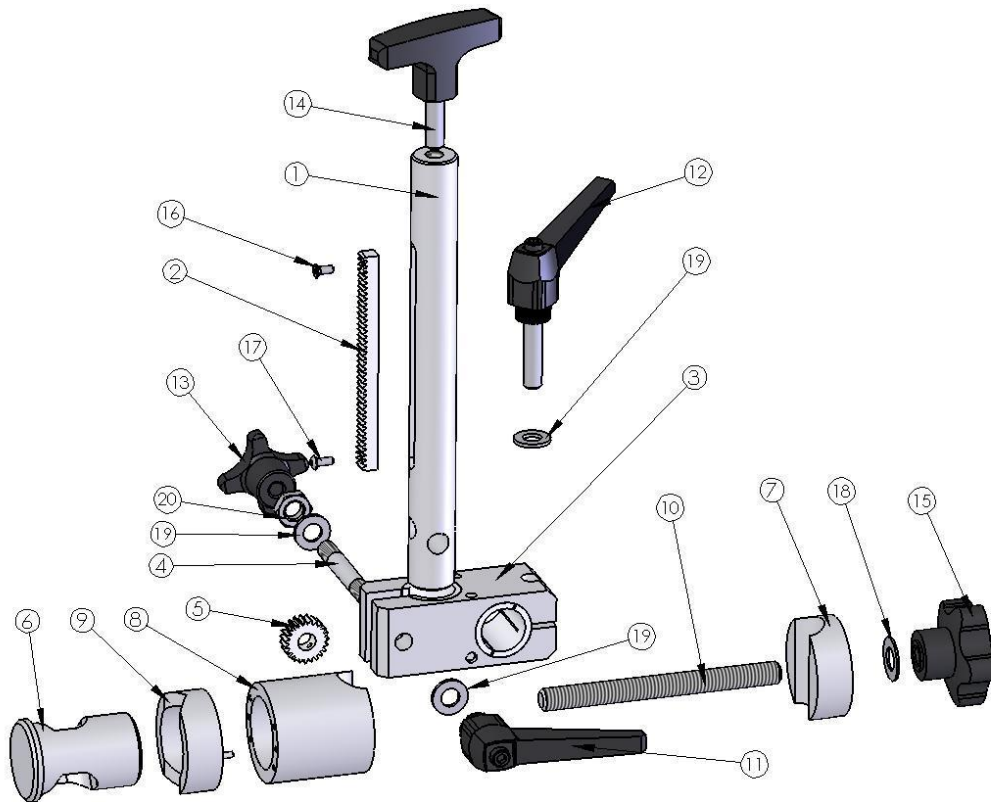

Pinion - Rack

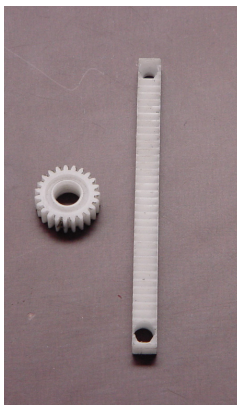

Torch Clamp



Jointed Wrist Assy

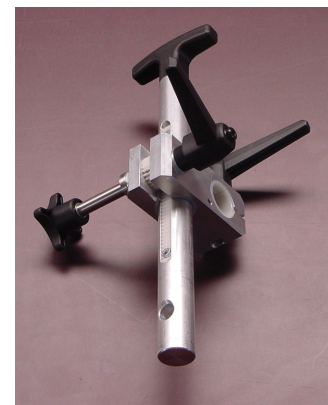

Item	Part No.	Qty	Description
1	66551	1	Pinion - Rack (Includes 2, 5)
2	66552	1	Torch Clamp (Includes 6-10, 15, 18)
3	66550	1	Jointed Wrist Assy (Includes 1-5, 11-14, 16, 17, 19, 20)

TORCH SUPPORT (PULL GUN) ILLUSTRATION

Torch Support Pull Gun
Part No. 69837

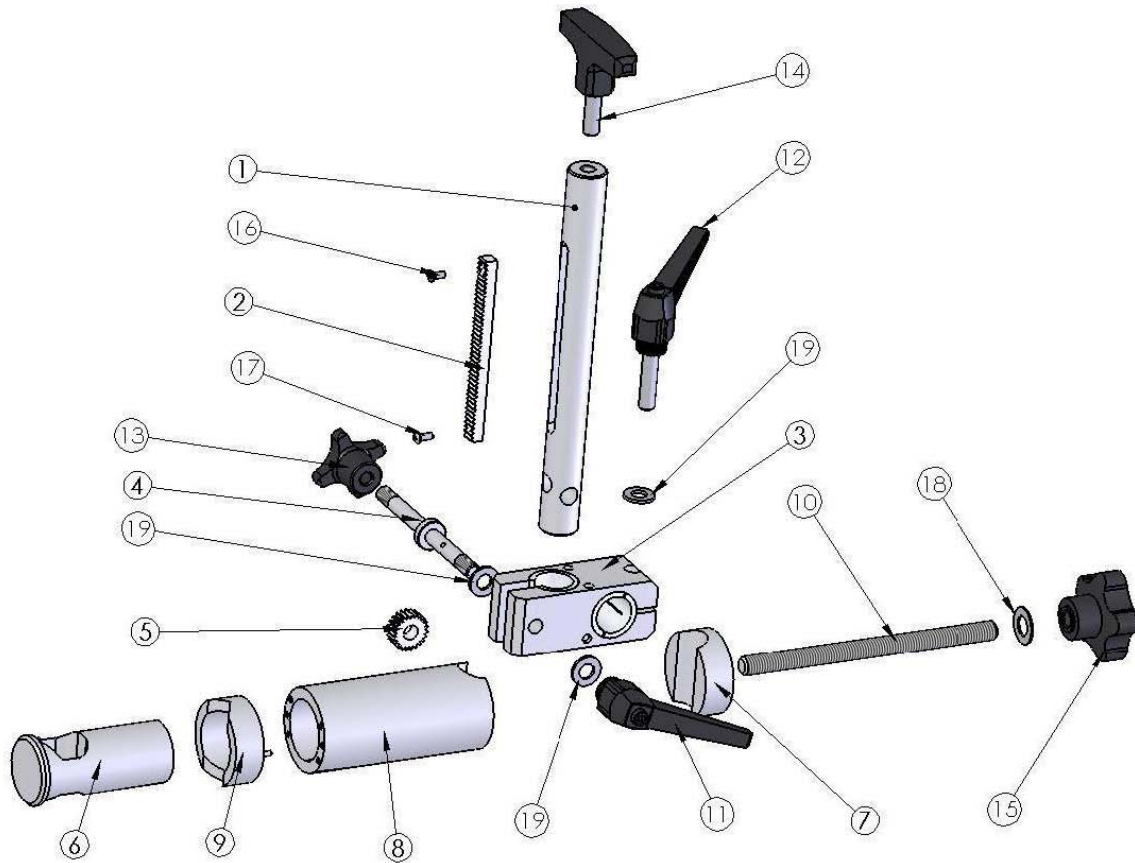

STANLEY®

Stanley Hydraulic Tools
3810 SE Naef Road
Milwaukie OR 97267-5698
503-659-5660
FAX 503-652-1780
www.stanleyhydraulics.com