

STANLEY®

SFP 1240 COMPACTION FORWARD PLATE



SFP 1240

PARTS MANUAL



© 2015 Stanley Black & Decker, Inc.
New Britain, CT 06053
U.S.A.
74927 3/2016 Ver 4

TABLE OF CONTENTS

MACHINE INFORMATION	3
ADHESIVES	4
SFP 1240 PARTS	5 - 10
SFP 1240 DECALS	11
SFP 1240 MAINTENANCE KIT	12
SFP 1240 WEAR PARTS KIT, SPRING ELEMENT	13
SFP 1240 WEAR PARTS KIT, BASE PLATE	14
SFP 1240 REPAIR KIT EXCITER	15

IMPORTANT

To fill out a Product Warranty Validation form, and for information on your warranty, visit Stanleyhydraulics.com and select the Company tab, Warranty.
(NOTE: The warranty Validation record must be submitted to validate the warranty).

SERVICING: This manual contains spare parts. Stanley Hydraulic Tools recommends that servicing this machine, other than routine maintenance, must be performed by an authorized and certified dealer. Please read the following warning.

⚠ WARNING

SERIOUS INJURY OR DEATH COULD RESULT FROM THE IMPROPER REPAIR OR SERVICE OF THIS TOOL.

REPAIRS AND / OR SERVICE TO THIS TOOL MUST ONLY BE DONE BY AN AUTHORIZED AND CERTIFIED DEALER.

For the nearest authorized and certified dealer, call Stanley Hydraulic Tools at the number listed on the back of this manual and ask for a Customer Service Representative.

MACHINE INFORMATION



Important!

In order to enable spare parts orders to be processed quickly and correctly, we require the following data:

1. Machine type: _____

2. Machine number: _____

3. Motor type: _____

(enter here for your own use; the data is shown on the type plate of the machine)

4. Article designation, article number and quantity.

5. Dispatch mode (by post, express or air mail delivery, forwarding agent or distributor.

6. Address.

Only original spare parts ensure a perfect condition tested by us; no warranty can be given if original spare parts are not used.

In case of warranty claims, send in the damaged part and notify your authorised dealer or our service department prior to repairing the damage (fax: 503-652-1780 / Phone: 503-659-5660).

In case of warranty claims for combustion engines, please contact the engine manufacturer or one of his authorised repair workshops to repair the damage or process the warranty claim.

Because of the steady development of our products, the shown illustrations are non-committal.

To order spare parts, please contact your local dealer or write to

Stanley Hydraulic Tools

3810 SE Naef Rd

Milwaukie, OR 97267

Ph: 503-659-5660

Fax: 503-652-1780

www.stanleyhydraulics.com

HONDA

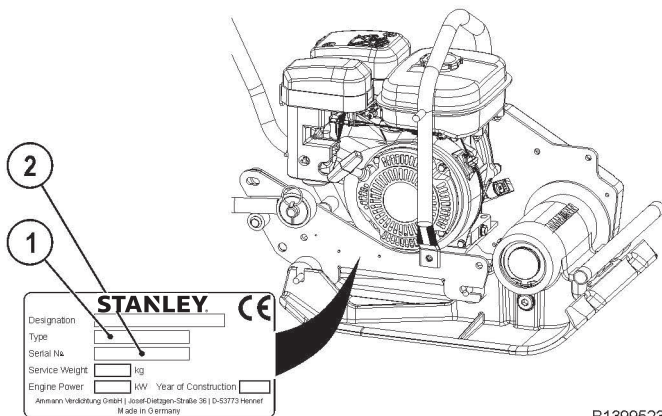
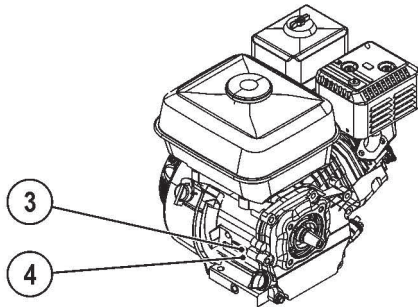

B1399523

ADHESIVES

Sealing- and bonding adhesives

A1	1	2-9L0 00 002	Loctite 262	250 ml
A2	2	2-806 05 260	Loctite 5205	300 ml
A3	3	2-806 02 010	Shell Alvania R3	1.0 kg
A4	4	2-9IH 00 001	Epple 22	250 ml
A5	5	2-9K0 00 020	Klüber 46 MR401	0.75 kg
A6	6	2-806 05 060	Atmosit Compact	75 ml
A7	7	2-806 05 200	Sico Met 50	20 g
A8	8	2-806 05 170	Omni Visc 1002	
A9	9	2-806 02 050	Shell Alvania EP1	600 g
A10	10	2-806 05 310	Beta Link K1	
A11	11	2-806 03 017	Metaflux	
A12	12	2-806 05 290	Loctite 5910	300 ml
A13	13	2-9L0 00 001	Loctite Cleaner 7063	450 ml
A14	14	2-9L0 00 006	Loctite 221	50 ml
A15	15	2-806 05 090	Omni Visc 1050	50 ml
	16	2-9L000005	Loctite 638	250 ml

TAB01010.cdr

as specified in the individual exploded views

Conversion: Newton-Meters to in. lb. and ft. lb.

Nm	In. lb.	Ft. lb.
5	44.2	3.6
10	88.5	7.3
15	132	11.0
20	177	14.7
25	221.2	18.4
30	265.5	22.1
35	309.7	25.8
40	354	29.5
45	398.2	33.1
50	442	36.8
55	486.7	40.5
60	531	44.2

SFP 1240 PARTS

NOTE: Item # 12 in this exploded view is a lift handle, if you need the sprinkler pipe see page 9, item 15.

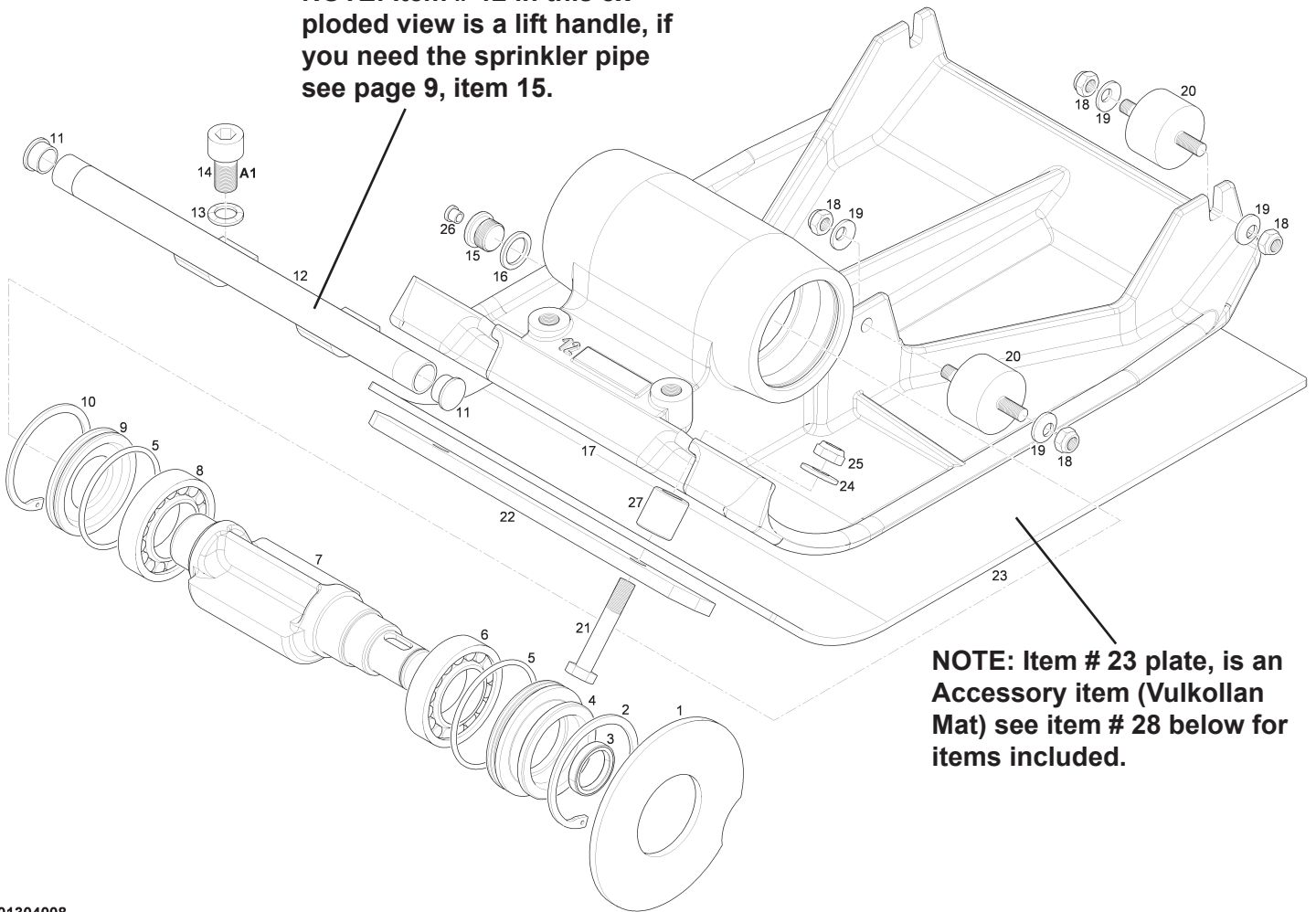

NOTE: Item # 23 plate, is an Accessory item (Vulkollan Mat) see item # 28 below for items included.

01304008

Item #	Part #	Qty	Description
1	75131	1	Joint disk
2	75488	1	Retaining ring
3	75417	1	Rotary seal ring
4	75128	1	Sealing flange
5	75429	2	O-Ring
6	75404	1	Cylindrical roller bearing
7	75123	1	Exciter shaft
8	75403	1	Cylindrical roller bearing
9	75104	1	Joint disk
10	75486	1	Retaining ring
11	75655	2	Plug
12	75144	1	Grip Handle, Note: this item is not part of the water sprinkler, see page 9.
13	75525	2	Lock washer
14	75693	2	Cap screw M16x30

Item #	Part #	Qty	Description
15	75671	1	Screw plug
16	75456	1	Joint washer
17	75108	1	Base plate
18	75754	8	Hexagon nut
19	75530	8	Conical spring washer
20	75389	4	Rubber buffer
21	75718	2	Cap screw M12x70
22	75107	1	Flat steel
23	75106	1	Plate
24	75528	2	Conical spring washer
25	75755	2	Hexagon nut M12
26	75651	1	Plug
27	75168	2	Bush
28	75879	1	Vulkollan plate, assy. (Includes items 21-25 & 27)

SFP 1240 PARTS

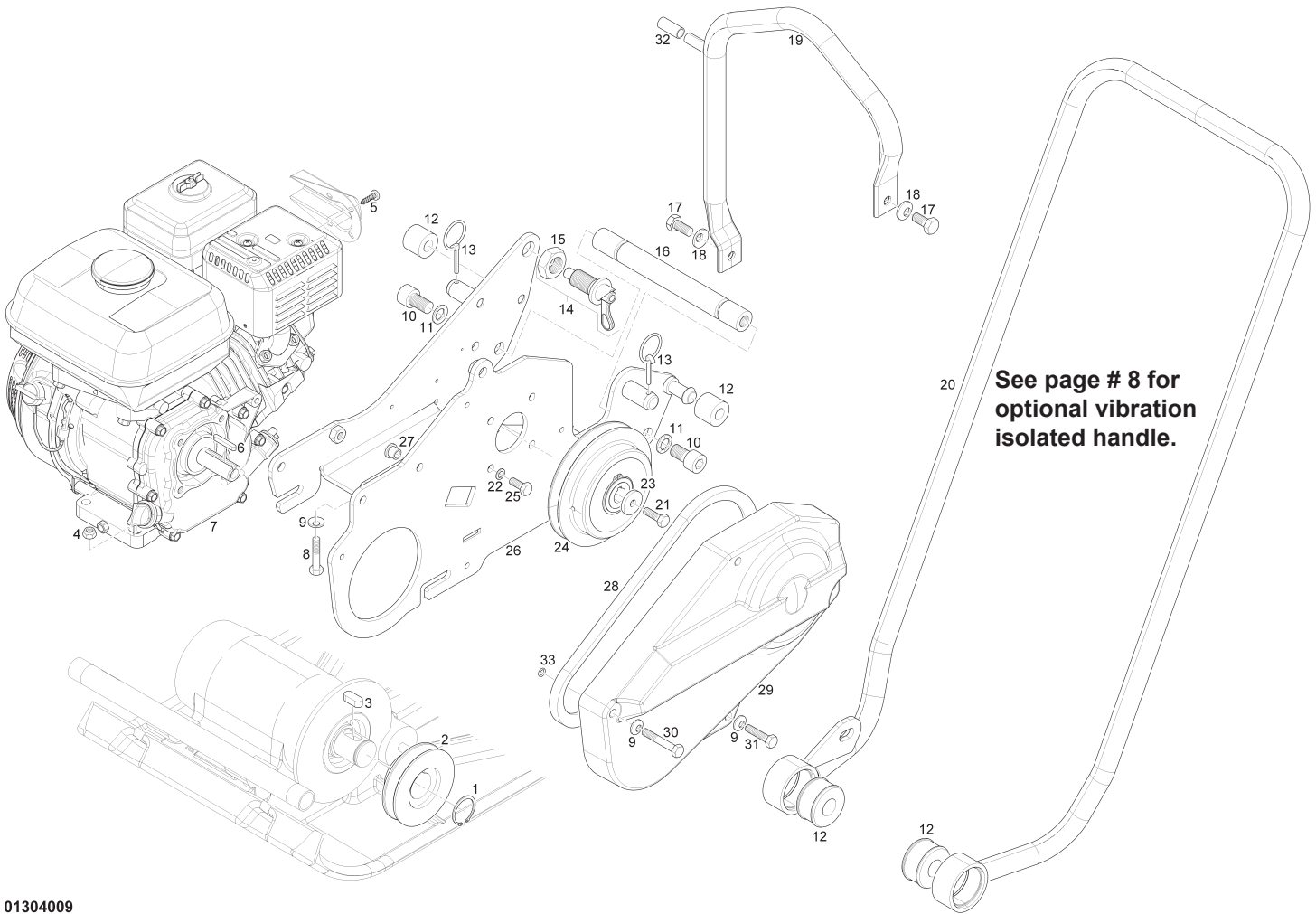

01304009

Item #	Part #	Qty	Description
1	75496	1	Retaining ring
2	75115	1	V-belt pulley
3	75479	1	Key
4	75753	4	Hexagon nut
5	75778	2	Plate screw
6	75872	1	Key
7	75630	1	Engine
8	75708	4	Hex head cap screw
9	75531	8	Conical spring washer
10	75691	2	Cap screw M14x25
11	75524	2	Lock washer
12	75105	2	Spring element, kit
13	75540	2	Split pin
14	75639	1	Locking bolt (Incl item 15)
15	75750	1	Hexagon nut
16	75132	1	Round bar steel
17	75732	2	Cap screw M10x22

Item #	Part #	Qty	Description
18	75530	2	Conical spring washer
19	75145	1	Hoop guard
20	75152	1	Tow bar
21	75728	1	Cap screw M8x25
22	75521	4	Lock washer
23	75316	1	Washer
24	75583	1	Centrifugal clutch, assy. (see page # 7)
25	75727	4	Cap screw M8x20
26	75135	1	Engine console
27	75650	1	Plug
28	75460	1	V-belt
29	75153	1	V-belt guard
30	75709	3	Cap screw M8x50
31	75730	1	Cap screw M8x35
32	75385	1	Hose
33	75433	4	O-Ring

SFP 1240 PARTS

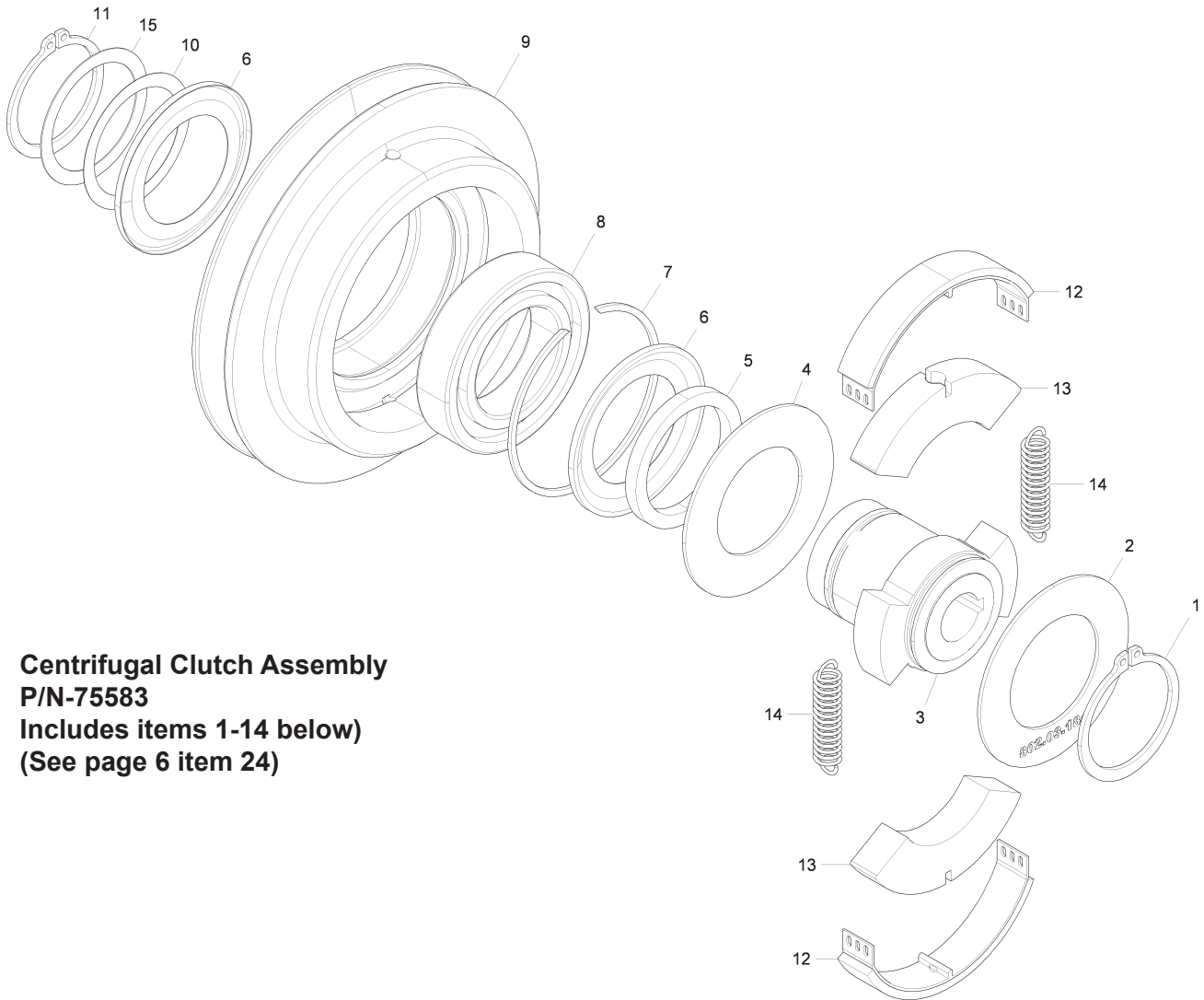

Centrifugal Clutch Assembly
P/N-75583
Includes items 1-14 below
(See page 6 item 24)

Item #	Part #	Qty	Description
1	75505	1	Retaining ring
2	75597	1	Covering
3	75595	1	Nave
4	75591	1	Disk
5	75598	1	Distance ring
6	75438	2	Nilos ring
7	75599	1	Retaining ring

Item #	Part #	Qty	Description
8	75397	1	Groove ball bearing
9	75596	1	Housing
10	75518	1	Adjusting washer
15	75519	1	Adjusting washer
11	75498	1	Retaining ring
12	75593	2	Lining strap
13	75592	2	Centrifugal weight
14	75594	2	Draw spring

SFP 1240 ACCESSORY (VIBRATION ISOLATED HANDLE)

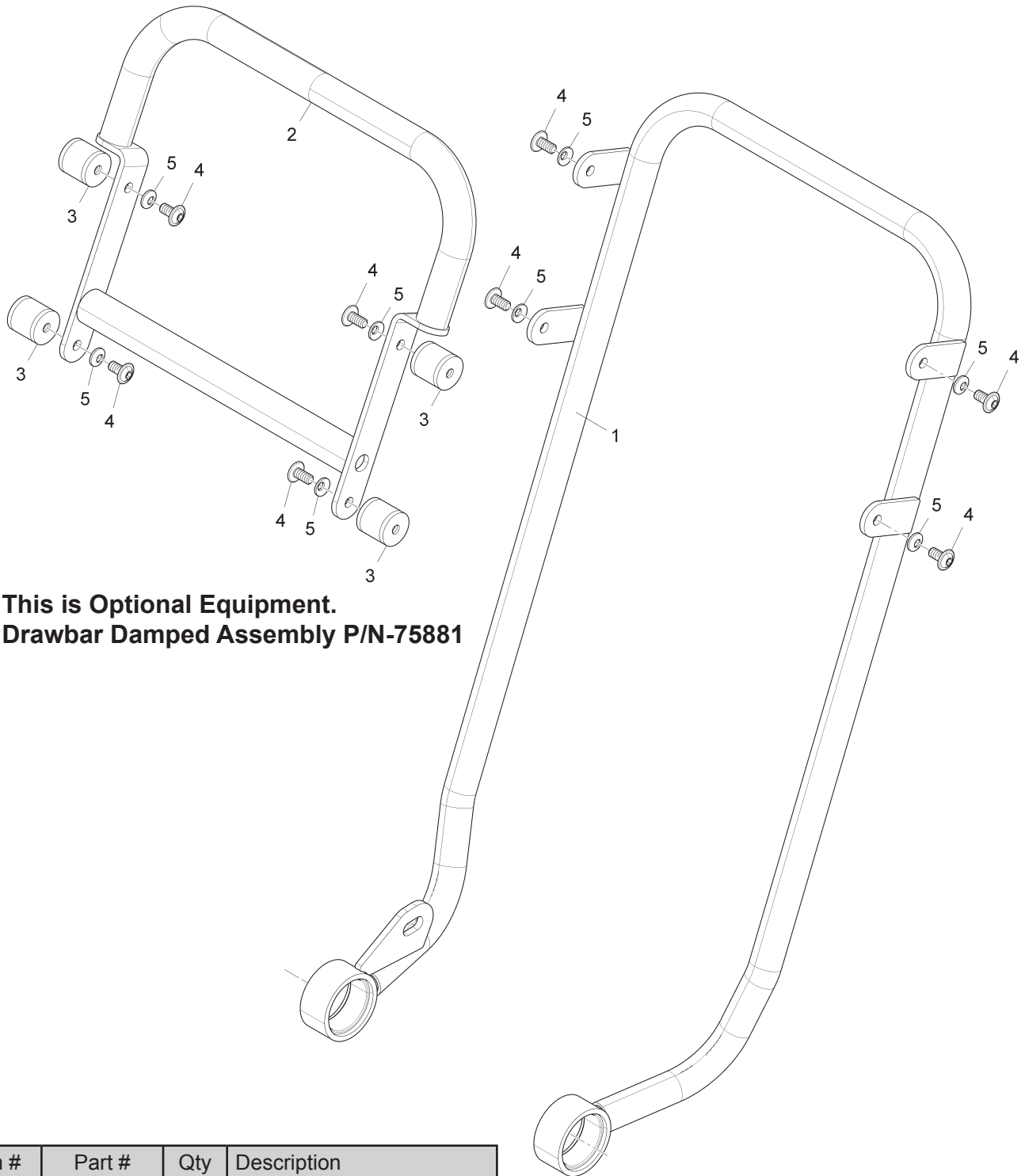

**This is Optional Equipment.
Drawbar Damped Assembly P/N-75881**

Item #	Part #	Qty	Description
1	75149	1	Drawbar, lower part
2	75148	1	Drawbar, upper part
3	75469	4	Rubber buffer
4	75776	8	Socket Button Head Screw
5	75531	8	Conical spring washer
6	75881	1	Drawbar damped, assy. (includes items 1 thru 5)

SFP 1240 PARTS

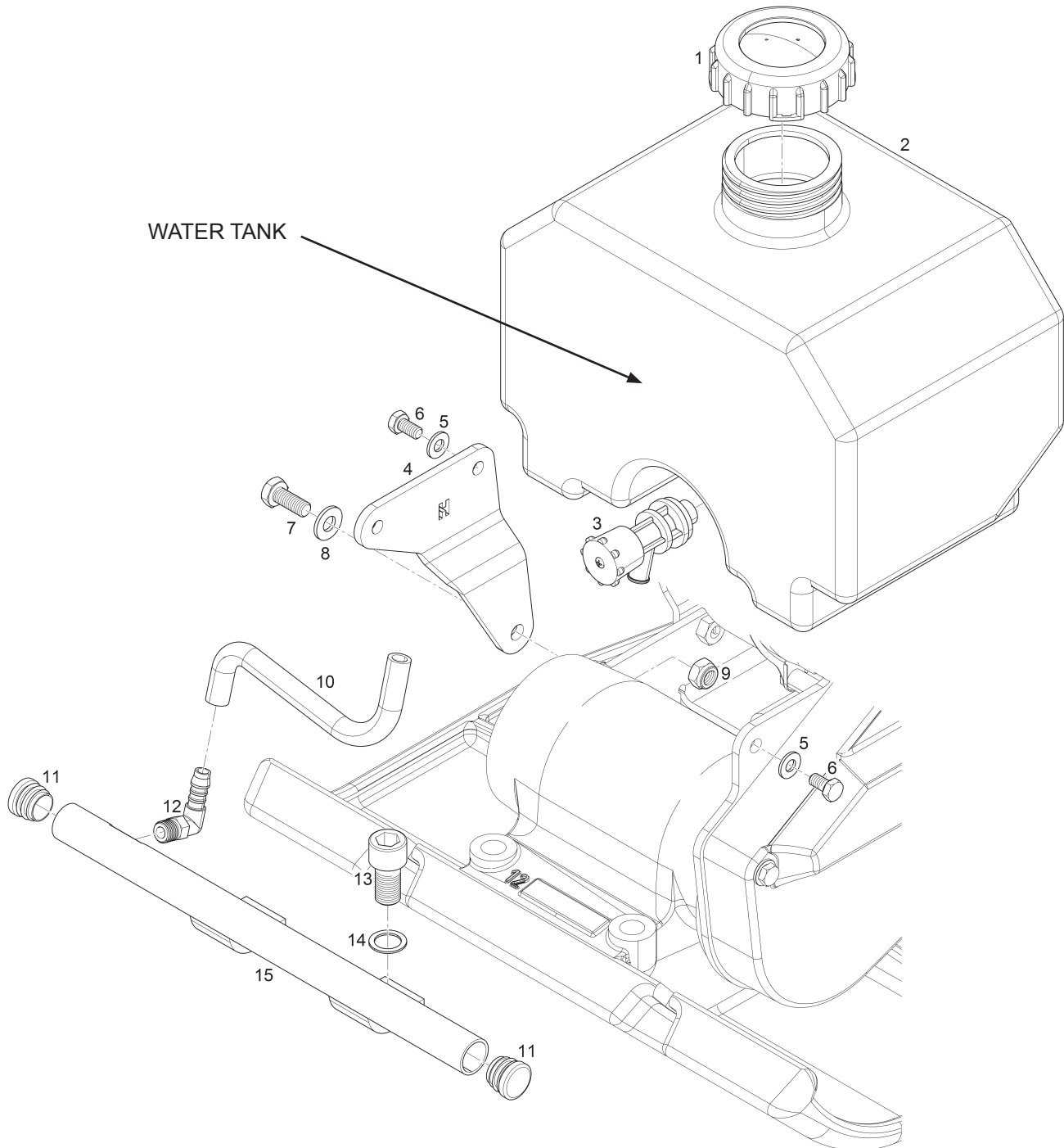

Item #	Part #	Qty	Description
1	75653	1	Cover Lid
2	75179	1	Water Tank
3	75647	1	Drain Cock
4	75159	1	Console
5	75531	4	Conical Spring Washer
6	75725	4	Cap Screw M8x16
7	75733	1	Cap Screw M10x25
8	75530	1	Conical Spring Washer

Item #	Part #	Qty	Description
9	75754	1	Hexagon Nut
10	75384	1	Hose
11	75655	2	Closing Plug
12	75560	1	Male Stud Elbow
13	75693	2	Socket Head Cap Screw
14	75525	2	Lock Washer
15	75160	1	Sprinkling Pipe

SFP 1240 ACCESSORY (TRANSPORTATION WHEELS)

This is Optional Equipment.
Chassis Assembly P/N-75878

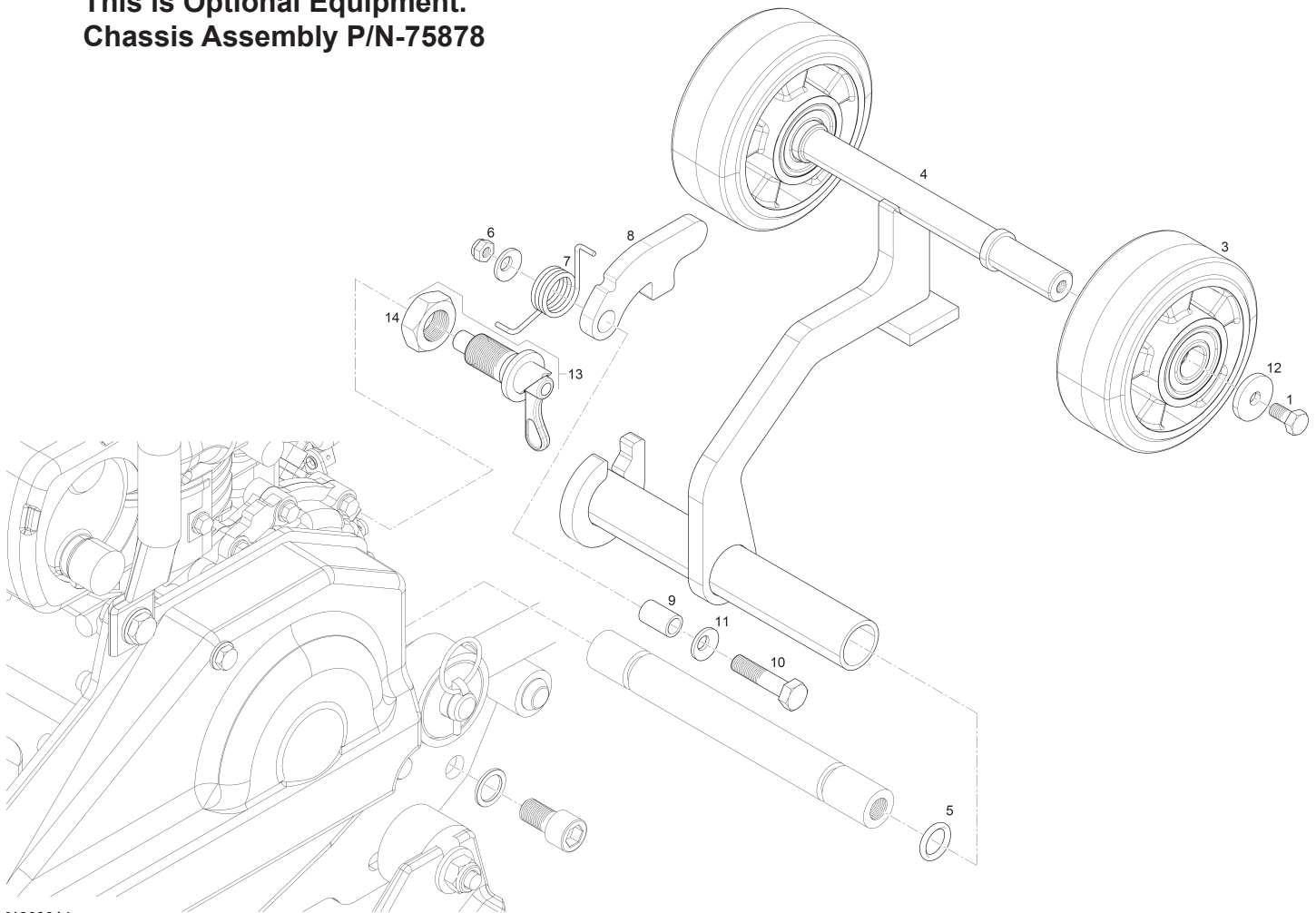

:1309014

Item #	Part #	Qty	Description
1	75725	2	Hexagon head cap screw
3	75635	2	Wheel
4	75164	1	Chassis
5	75421	2	O-Ring
6	75754	1	Hexagon nut
7	75162	1	Torsion spring
8	75161	1	Hook
9	75163	1	Bush

Item #	Part #	Qty	Description
10	75689	1	Socket Head Cap Screw
11	75530	2	Conical spring washer
12	75316	2	Washer
13	75639	1	Locking bolt (Incl item 14)
14	75750	1	Hexagon nut
17	75878	1	Chassis, assy. (includes items 1 thru 14)

SFP 1240 DECALS

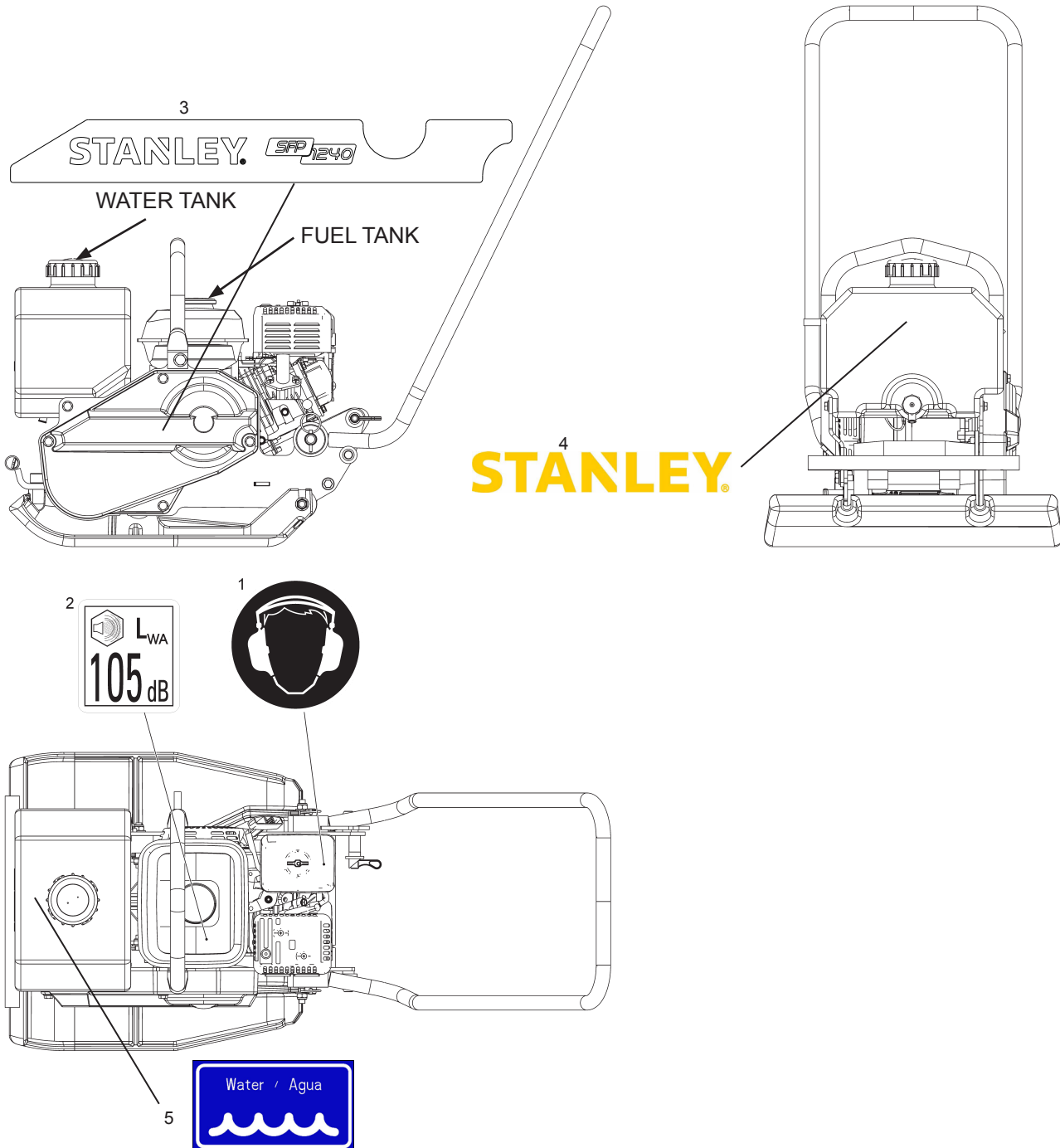

Item #	Part #	Qty	Description
1	75103	1	Hearing Protection
2	75100	1	Sound level decal
3	74903	1	Decal SFP 1240
4	74920	1	Stanley Logo
5	76495	1	Water Tank Decal

SFP 1240 MAINTENANCE KIT

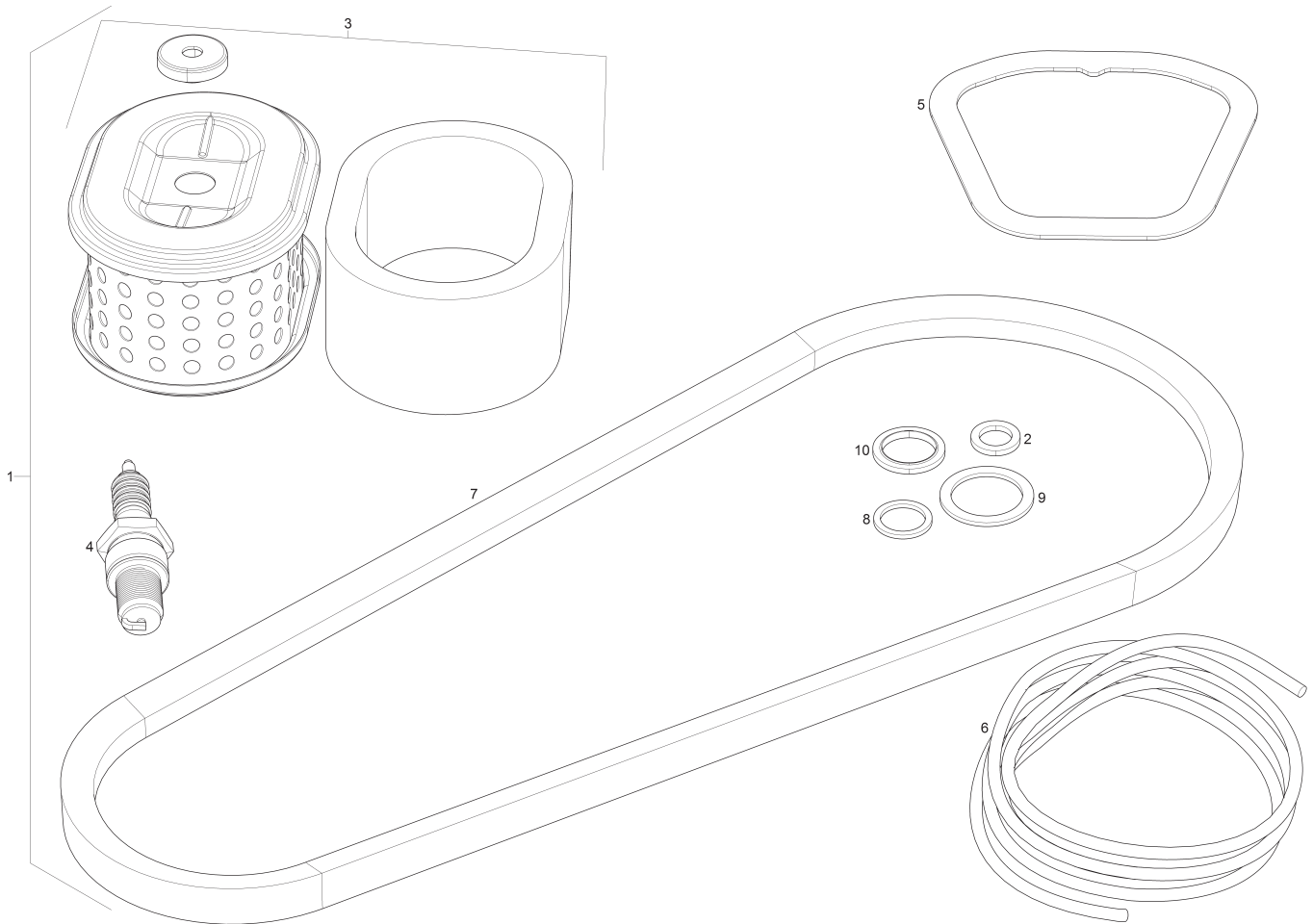

E1309019

Item #	Part #	Qty	Description
1	75800	1	Maintenance Kit
2	75871	1	Washer
3	75575	1	Air Filter
4	75877	1	Spark Plug
5	75860	1	Valve Cover Gasket
6	75869	1	Starter Rope
7	75460	1	V-Belt
8	75453	1	Joint Washer
9	75456	1	Joint Washer
10	75458	1	Joint Washer

SFP 1240 WEAR PARTS KIT, SPRING ELEMENT

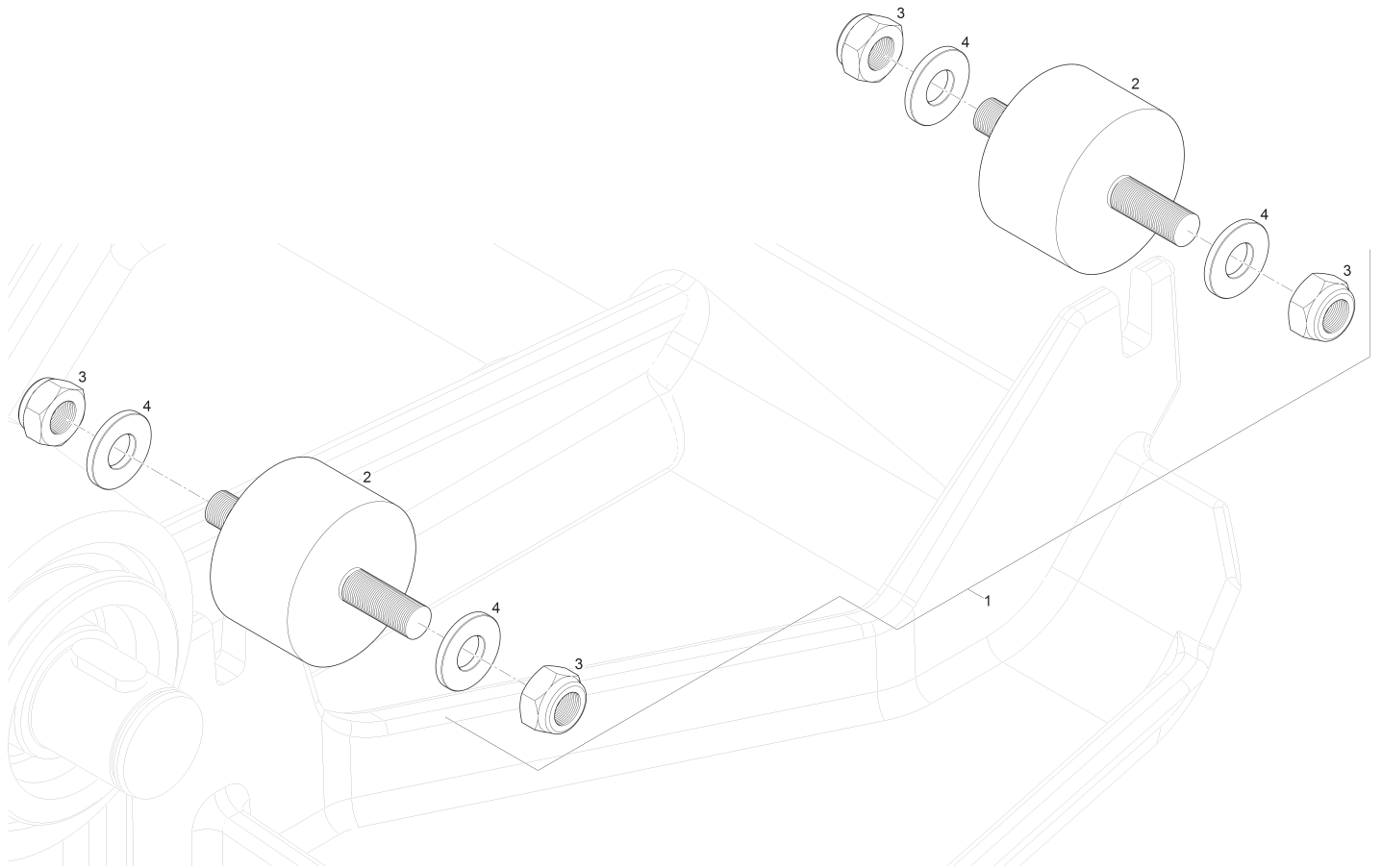

Item #	Part #	Qty	Description
1	75838	1	Wear Parts Kit Spring Element
2	75389	4	Rubber Buffer
3	75754	8	Hexagon Nut
4	75530	8	Conical Spring Washer

SFP 1240 WEAR PARTS KIT, BASE PLATE

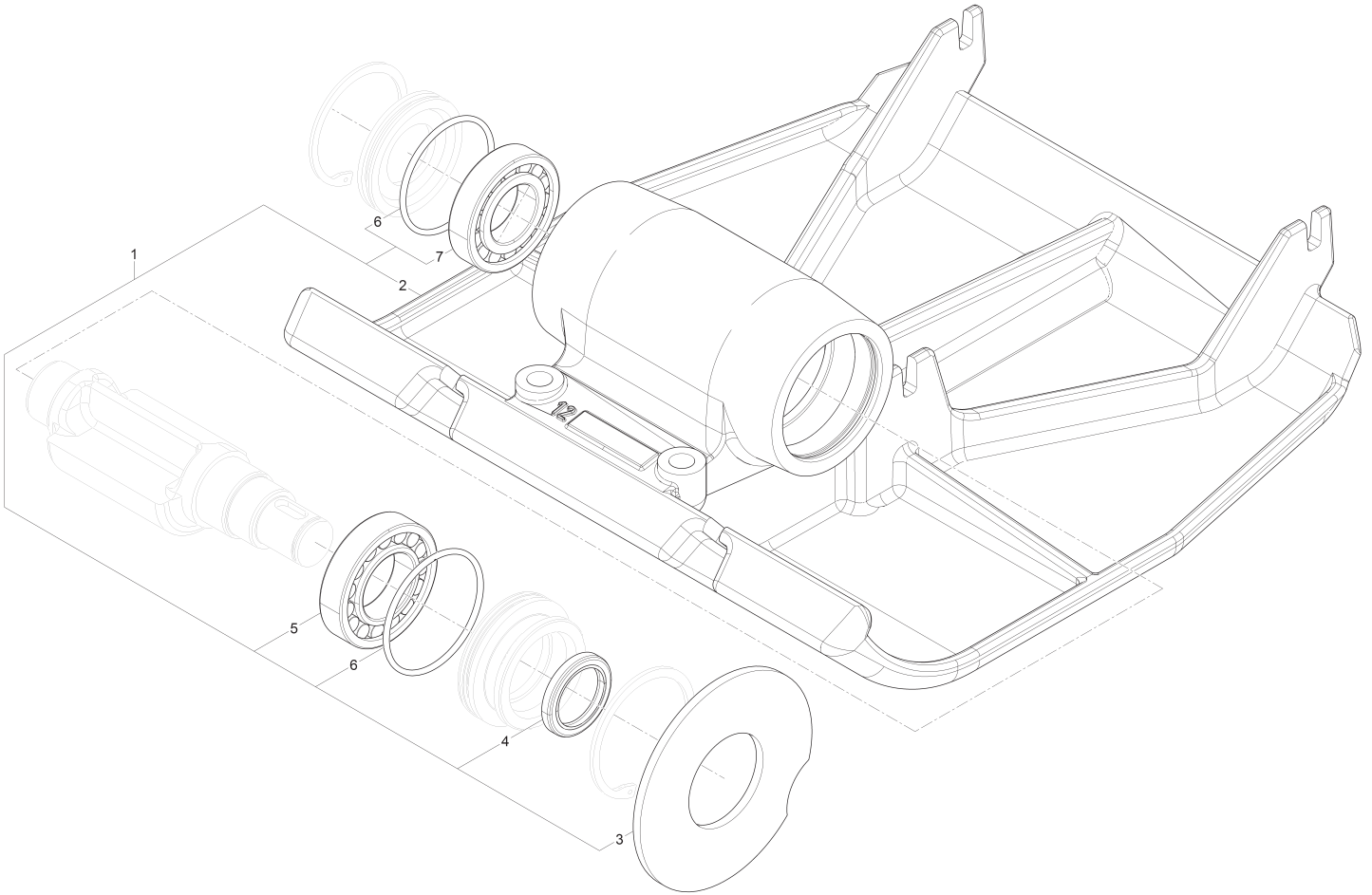

Item #	Part #	Qty	Description
1	75840	1	Wear Parts Kit Base Plate
2	75108	1	Base Plate
3	75131	1	Joint Disc
4	75417	1	Shaft Sealing Ring
5	75404	1	Cylindrical Roller Bearing
6	75429	2	O-Ring
7	75403	1	Cylindrical Roller Bearing

SFP 1240 REPAIR KIT EXCITER

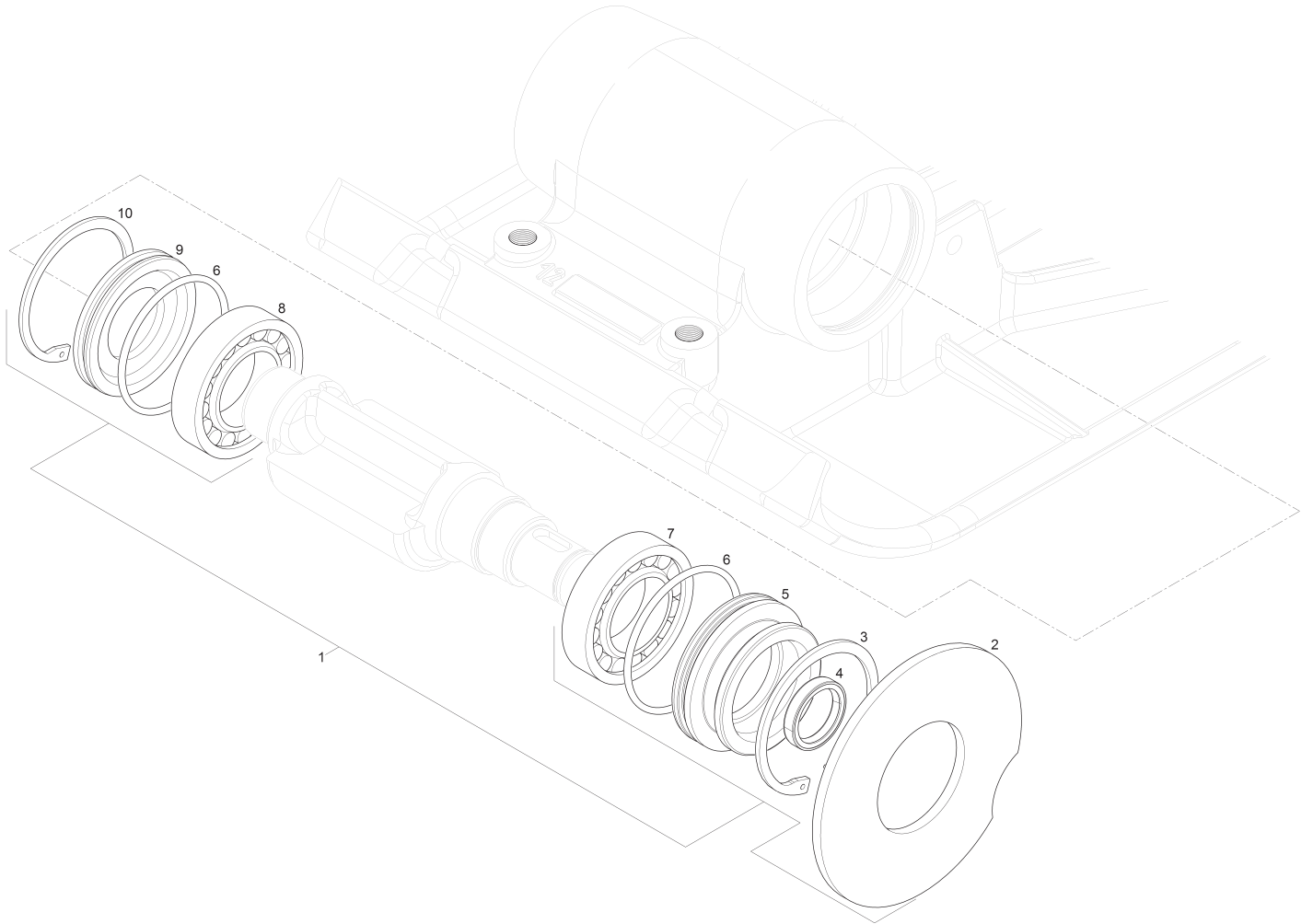

Item #	Part #	Qty	Description
1	75796	1	Repair Kit Exciter
2	75131	1	Joint Disc
3	75488	1	Retaining Ring
4	75417	1	Shaft Sealing Ring
5	75128	1	Sealing Flange
6	75429	2	O-Ring
7	75404	1	Cylindrical Roller Bearing
8	75403	1	Cylindrical Roller Bearing
9	75104	1	Joint Disc
10	75486	1	Retaining Ring

STANLEY®

Stanley Hydraulic Tools
3810 SE Naef Road
Milwaukie, Oregon 97267-5698 USA
(503) 659-5660 / Fax (503) 652-1780
www.stanleyhydraulics.com