

STANLEY®

TT46 HYDRAULIC TIE TAMPER



USER MANUAL Safety, Operation and Maintenance



© 2014 Stanley Black & Decker, Inc.
New Britain, CT 06053
U.S.A.
60685 2-2015 Ver-10

DECLARATION OF CONFORMITY

DECLARATION OF CONFORMITY
ÜBEREINSTIMMUNGS-ERKLÄRUNG
DECLARATION DE CONFORMITE CEE
DECLARACION DE CONFORMIDAD
DICHIARAZIONE DI CONFORMITA

STANLEY.
Hydraulic Tools



I, the undersigned:
Ich, der Unterzeichnende:
Je soussigné:
El abajo firmante:
Io sottoscritto:

Weisbeck, Andy

Surname and First names/Familiennamen und Vornamen/Nom et prénom/Nombre y apellido/Cognome e nome

hereby declare that the equipment specified hereunder:
bestätige hiermit, daß erklaren Produkt genannten Werk oder Gerät:
déclare que l'équipement visé ci-dessous:
Por la presente declaro que el equipo se especifica a continuación:
Dichiaro che le apparecchiature specificate di seguito:

- Category: **Tie Tamper, Hydraulic**
Kategorie:
Catégorie:
Categoria:
Categoria:
- Make/Marke/Marque/Marca/Marca **Stanley**
- Type/Typ/Type/Tipo/Tipo: **TT46133**
- Serial number of equipment:
Seriennummer des Geräts:
Numéro de série de l'équipement:
Numero de serie del equipo:
Matricola dell'attrezzatura: **All**

Has been manufactured in conformity with
Wurde hergestellt in Übereinstimmung mit
Est fabriqué conformément
Ha sido fabricado de acuerdo con
E' stata costruita in conformità con

Directive/Standards Richtlinie/Standards Directives/Normes Directriz/Los Normas Direttiva/Norme	No. Nr Numéro No n.	Approved body Prüfung durch Organisme agréé Aprobado Collaudato
Machinery Directive EN ISO EN	2006/42/EC:2006 3744:2010 11148-4:2010	Self Self Self

- Special Provisions: **None**
Spezielle Bestimmungen:
Dispositions particulières:
Provisiones especiales:
Disposizioni speciali:

Sound Power Level: 107 dBA
Vibration Level: 6.3 m/s²

- Representative in the Union: **Patrick Vervier, Stanley Dubuis 17-19, rue Jules Berthonneau-BP 3406 41034 Blois Cedex, France.**
Vertreter in der Union/Représentant dans l'union/Representante en la Union/Rappresentante presso l'Unione

Done at/Ort/Fait à/Dado en/Fatto a Stanley Hydraulic Tools, Milwaukie, Oregon USA Date/Datum/le/Fecha/Data 1-10-11

Signature/Unterschrift/Signature/Firma/Firma

Position/Position/Fonction/Cargo/Posizione Director of Product Development

TABLE OF CONTENTS

DECLARATION OF CONFORMITY	2
SAFETY SYMBOLS.....	4
SAFETY PRECAUTIONS.....	5
TOOL STICKERS & TAGS	6
TOOL HOSE INFORMATION	7-8
HTMA REQUIREMENTS.....	9
OPERATION.....	10
PREOPERATION PROCEDURES.....	10
TOOL OPERATION	10
COLD WEATHER OPERATION.....	10
EQUIPMENT PROTECTION & CARE.....	11
TROUBLESHOOTING.....	12
CHARGING THE ACCUMULATOR	13-14
SPECIFICATIONS	15
ACCESSORIES.....	15
SERVICE TOOLS	15
SOUND POWER AND VIBRATION DECLARATION	15
TT46113 & TT46133 ILLUSTRATION	16
TT46113 & TT46133 PARTS LIST.....	17
TT46112/TT4611204 ILLUSTRATION	18
TT46112/TT4611204 PARTS LIST	19

IMPORTANT

To fill out a Product Warranty Validation form, and for information on your warranty, visit Stanleyhydraulics.com and select the Company tab, Warranty.
(NOTE: The warranty Validation record must be submitted to validate the warranty).

SERVICING: This manual contains safety, operation, and routine maintenance instructions. Stanley Hydraulic Tools recommends that servicing of hydraulic tools, other than routine maintenance, must be performed by an authorized and certified dealer. Please read the following warning.

⚠ WARNING

SERIOUS INJURY OR DEATH COULD RESULT FROM THE IMPROPER REPAIR OR SERVICE OF THIS TOOL.

REPAIRS AND / OR SERVICE TO THIS TOOL MUST ONLY BE DONE BY AN AUTHORIZED AND CERTIFIED DEALER.

For the nearest authorized and certified dealer, call Stanley Hydraulic Tools at the number listed on the back of this manual and ask for a Customer Service Representative.

SAFETY PRECAUTIONS

Tool operators and maintenance personnel must always comply with the safety precautions given in this manual and on the stickers and tags attached to the tool and hose.

These safety precautions are given for your safety. Review them carefully before operating the tool and before performing general maintenance or repairs.

Supervising personnel should develop additional precautions relating to the specific work area and local safety regulations. If so, place the added precautions in the space provided on page 5.

The tool will provide safe and dependable service if operated in accordance with the instructions given in this manual. Read and understand this manual and any stickers and tags attached to the tool and hose before operation. Failure to do so could result in personal injury or equipment damage.



- The operator must start in a work area without bystanders. Flying debris can cause serious injury.
- Do not operate the tool unless thoroughly trained or under the supervision of an instructor. Establish a training program for all operators to ensure safe operation.
- Always wear safety equipment such as goggles, ear and head protection, and safety shoes at all times when operating the tool. Use gloves and aprons when necessary.
- The operator must be familiar with all prohibited work areas such as excessive slopes and dangerous terrain conditions.
- Maintain proper footing and balance at all times.
- Do not inspect or clean the tool while the hydraulic power source is connected. Accidental engagement of the tool can cause serious injury.
- Always connect hoses to the tool hose couplers before energizing the hydraulic power source. Be sure all hose connections are tight and are in good condition.
- Do not operate the tool at oil temperatures above 140°F/60°C. Operation at higher temperatures can cause higher than normal temperatures at the tool which can result in operator discomfort.
- Do not operate a damaged, improperly adjusted, or incompletely assembled tie tamper.

- Never wear loose clothing that can get entangled in the working parts of the tool.
- Keep all parts of your body away from the moving parts. Long hair or loose clothing can become drawn into moving components.
- Do not weld, cut with an acetylene torch or hardface the tie tamper tool. Do not operate a damaged, improperly adjusted, or incompletely assembled tool.
- Always use accessories that conform to the specifications given in the OPERATION section of this manual.
- Release the trigger if the power supply has been interrupted.
- When working near electrical conductors, always assume that all conductors are energized and that insulation, clothing and hoses can conduct electricity. Use hose labeled and certified as non-conductive.
- To avoid personal injury or equipment damage, all tool repair, maintenance and service must only be performed by authorized and properly trained personnel.
- Do not carry the tool by hoses.
- **Warning:** Use of this tool on certain materials during demolition could generate dust potentially containing a variety of hazardous substances such as asbestos, silica or lead. Inhalation of dust containing these or other hazardous substances could result in serious injury, cancer or death. Protect yourself and those around you. Research and understand the materials you are cutting. Follow correct safety procedures and comply with all applicable national, state or provisional health and safety regulations relating to them, including, if appropriate arranging for the safe disposal of the materials by a qualified person.

TOOL STICKERS & TAGS



28322
CE STICKER (CE)



25610
RAILROAD HELP DESK STICKER



28409
COMPOSITE STICKER



11206
CIRCUIT TYPE C STICKER (CE)

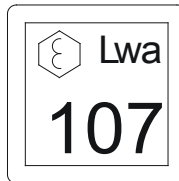

17784
SOUND POWER STICKER

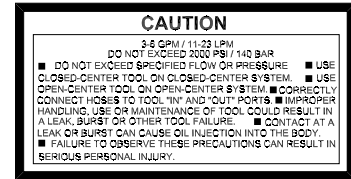

07589
CAUTION/GPM STICKER



23230
NAME TAG (4-6 GPM MODELS)
65049
NAME TAG (10 GPM MODEL)

NOTE:
THE INFORMATION LISTED ON THE STICKERS SHOWN, MUST BE LEGIBLE AT ALL TIMES.
REPLACE DECALS IF THEY BECOME WORN OR DAMAGED. REPLACEMENTS ARE AVAILABLE FROM YOUR LOCAL STANLEY DISTRIBUTOR.

The safety tag (P/N 15875) at right is attached to the tool when shipped from the factory. Read and understand the safety instructions listed on this tag before removal. We suggest you retain this tag and attach it to the tool when not in use.

DANGER

1. FAILURE TO USE HYDRAULIC HOSE LABELED AND CERTIFIED AS NON-CONDUCTIVE WHEN USING HYDRAULIC TOOLS ON OR NEAR ELECTRICAL LINES MAY RESULT IN DEATH OR SERIOUS INJURY.
BEFORE USING HOSE LABELED AND CERTIFIED AS NON-CONDUCTIVE ON OR NEAR ELECTRIC LINES BE SURE THE HOSE IS MAINTAINED AS NON-CONDUCTIVE. THE HOSE SHOULD BE REGULARLY TESTED FOR ELECTRIC CURRENT LEAKAGE IN ACCORDANCE WITH YOUR SAFETY DEPARTMENT INSTRUCTIONS.
2. A HYDRAULIC LEAK OR BURST MAY CAUSE OIL INJECTION INTO THE BODY OR CAUSE OTHER SEVERE PERSONAL INJURY.
 - A. DO NOT EXCEED SPECIFIED FLOW AND PRESSURE FOR THIS TOOL. EXCESS FLOW OR PRESSURE MAY CAUSE A LEAK OR BURST.
 - B. DO NOT EXCEED RATED WORKING PRESSURE OF HYDRAULIC HOSE USED WITH THIS TOOL. EXCESS PRESSURE MAY CAUSE A LEAK OR BURST.
 - C. CHECK TOOL HOSE COUPLERS AND CONNECTORS DAILY FOR LEAKS. DO NOT FEEL FOR LEAKS WITH YOUR HANDS. CONTACT WITH A LEAK MAY RESULT IN SEVERE PERSONAL INJURY.

IMPORTANT

READ OPERATION MANUAL AND SAFETY INSTRUCTIONS FOR THIS TOOL BEFORE USING IT.

USE ONLY PARTS AND REPAIR PROCEDURES APPROVED BY STANLEY AND DESCRIBED IN THE OPERATION MANUAL.

TAG TO BE REMOVED ONLY BY TOOL OPERATOR.

SEE OTHER SIDE

DANGER

- D. DO NOT LIFT OR CARRY TOOL BY THE HOSES. DO NOT ABUSE HOSE. DO NOT USE KINKED, TORN OR DAMAGED HOSE.
3. MAKE SURE HYDRAULIC HOSES ARE PROPERLY CONNECTED TO THE TOOL BEFORE PRESSURING SYSTEM. SYSTEM PRESSURE HOSE MUST ALWAYS BE CONNECTED TO TOOL "IN" PORT. SYSTEM RETURN HOSE MUST ALWAYS BE CONNECTED TO TOOL "OUT" PORT. REVERSING CONNECTIONS MAY CAUSE REVERSE TOOL OPERATION WHICH CAN RESULT IN SEVERE PERSONAL INJURY.
4. DO NOT CONNECT OPEN-CENTER TOOLS TO CLOSED-CENTER HYDRAULIC SYSTEMS. THIS MAY RESULT IN LOSS OF OTHER HYDRAULIC FUNCTIONS POWERED BY THE SAME SYSTEM AND/OR SEVERE PERSONAL INJURY.
5. BYSTANDERS MAY BE INJURED IN YOUR WORK AREA. KEEP BYSTANDERS CLEAR OF YOUR WORK AREA.
6. WEAR HEARING, EYE, FOOT, HAND AND HEAD PROTECTION.
7. TO AVOID PERSONAL INJURY OR EQUIPMENT DAMAGE, ALL TOOL REPAIR MAINTENANCE AND SERVICE MUST ONLY BE PERFORMED BY AUTHORIZED AND PROPERLY TRAINED PERSONNEL.

IMPORTANT

READ OPERATION MANUAL AND SAFETY INSTRUCTIONS FOR THIS TOOL BEFORE USING IT.

USE ONLY PARTS AND REPAIR PROCEDURES APPROVED BY STANLEY AND DESCRIBED IN THE OPERATION MANUAL.

TAG TO BE REMOVED ONLY BY TOOL OPERATOR.

SEE OTHER SIDE

SAFETY TAG P/N 15875 (Shown smaller than actual size)

HOSE TYPES

The rated working pressure of the hydraulic hose must be equal to or higher than the relief valve setting on the hydraulic system. There are three types of hydraulic hose that meet this requirement and are authorized for use with Stanley Hydraulic Tools. They are:

Certified non-conductive — constructed of thermoplastic or synthetic rubber inner tube, synthetic fiber braid reinforcement, and weather resistant thermoplastic or synthetic rubber cover. *Hose labeled **certified non-conductive** is the only hose authorized for use near electrical conductors.*

Wire-braided (conductive) — constructed of synthetic rubber inner tube, single or double wire braid reinforcement, and weather resistant synthetic rubber cover. *This hose is **conductive** and must never be used near electrical conductors.*

Fabric-braided (not certified or labeled non-conductive) — constructed of thermoplastic or synthetic rubber inner tube, synthetic fiber braid reinforcement, and weather resistant thermoplastic or synthetic rubber cover. *This hose is **not certified non-conductive** and must never be used near electrical conductors.*

HOSE SAFETY TAGS

To help ensure your safety, the following DANGER tags are attached to all hose purchased from Stanley Hydraulic Tools. DO NOT REMOVE THESE TAGS.

If the information on a tag is illegible because of wear or damage, replace the tag immediately. A new tag may be obtained from your Stanley Distributor.

THE TAG SHOWN BELOW IS ATTACHED TO “CERTIFIED NON-CONDUCTIVE” HOSE

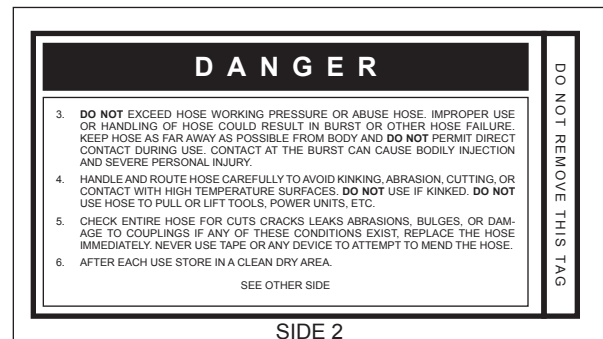
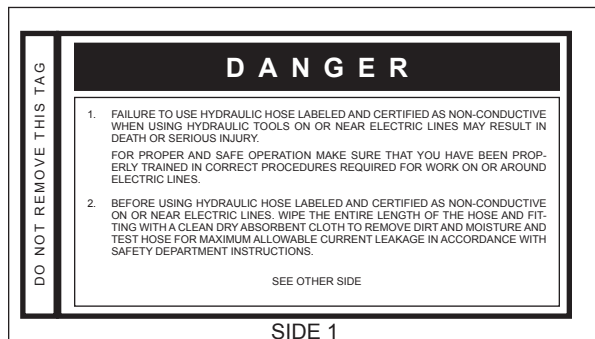

(Shown smaller than actual size)

THE TAG SHOWN BELOW IS ATTACHED TO “CONDUCTIVE” HOSE.

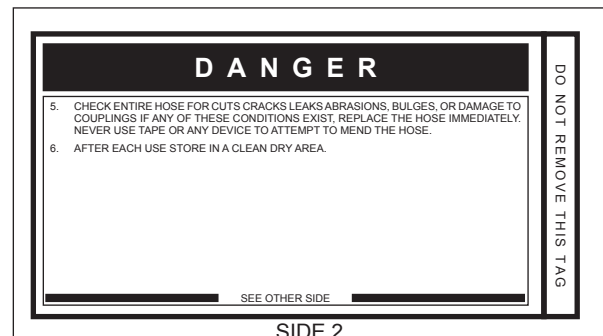
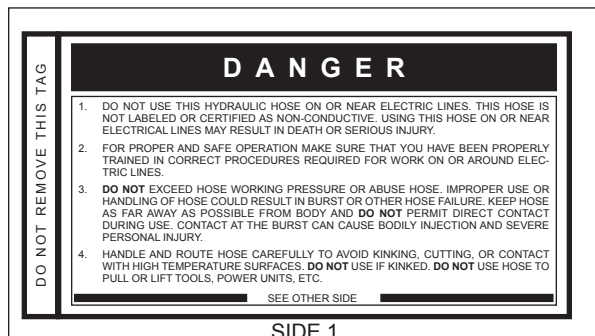

(Shown smaller than actual size)

HOSE RECOMMENDATIONS

Tool to Hydraulic Circuit Hose Recommendations

The chart to the right shows recommended minimum hose diameters for various hose lengths based on gallons per minute (gpm)/liters per minute (lpm). These recommendations are intended to keep return line pressure (back pressure) to a minimum acceptable level to ensure maximum tool performance.

This chart is intended to be used for hydraulic tool applications only based on Stanley Hydraulic Tools tool operating requirements and should not be used for any other applications.

All hydraulic hose must have at least a rated minimum working pressure equal to the maximum hydraulic system relief valve setting.

All hydraulic hose must meet or exceed specifications as set forth by SAE J517.

Oil Flow		Hose Lengths		Inside Diameter		USE (Press/Return)	Min. Working Pressure	
GPM	LPM	FEET	METERS	INCH	MM		PSI	BAR
Certified Non-Conductive Hose - Fiber Braid - for Utility Bucket Trucks								
4-9	15-34	up to 10	up to 3	3/8	10	Both	2250	155
Conductive Hose - Wire Braid or Fiber Braid -DO NOT USE NEAR ELECTRICAL CONDUCTORS								
4-6	15-23	up to 25	up to 7.5	3/8	10	Both	2500	175
4-6	15-23	26-100	7.5-30	1/2	13	Both	2500	175
5-10.5	19-40	up to 50	up to 15	1/2	13	Both	2500	175
5-10.5	19-40	51-100	15-30	5/8	16	Both	2500	175
5-10.5	19-40	100-300	30-90	5/8	16	Pressure	2500	175
10-13	38-49	up to 50	up to 15	3/4	19	Return	2500	175
10-13	38-49	51-100	15-30	5/8	16	Both	2500	175
10-13	38-49	100-200	30-60	3/4	19	Pressure	2500	175
13-16	49-60	up to 25	up to 8	5/8	16	Return	2500	175
13-16	49-60	26-100	8-30	3/4	19	Return	2500	175
				1	25.4	Return	2500	175
				5/8	16	Pressure	2500	175
				3/4	19	Return	2500	175
				3/4	19	Pressure	2500	175
				1	25.4	Return	2500	175

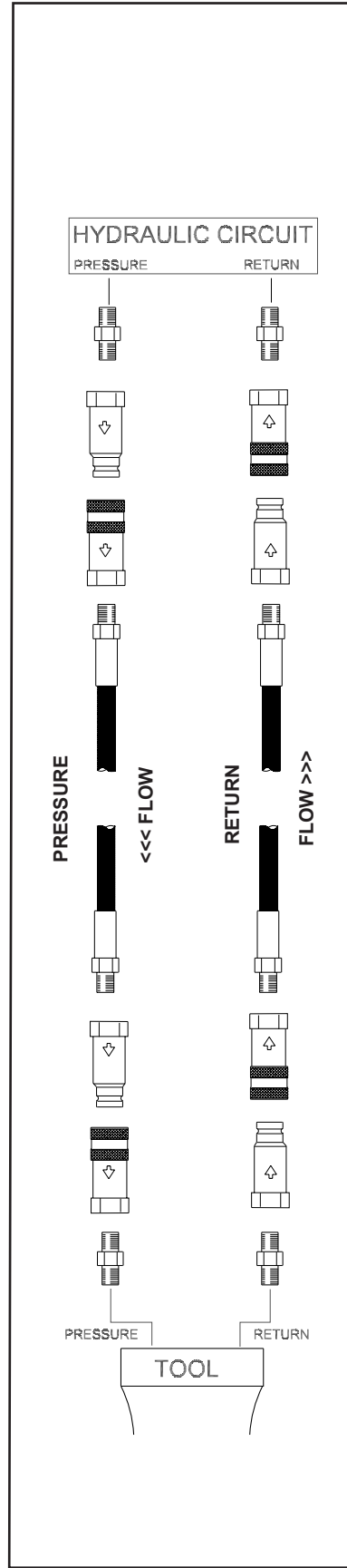

Figure 1. Typical Hose Connections

HTMA / EHTMA REQUIREMENTS

HTMA / EHTMA REQUIREMENTS

HTMA

HYDRAULIC SYSTEM REQUIREMENTS

TOOL TYPE

TYPE I

TYPE II

TYPE RR

TYPE III

Flow Range	4-6 gpm (15-23 lpm)	7-9 gpm (26-34 lpm)	9-10.5 gpm (34-40 lpm)	11-13 gpm (42-49 lpm)
Nominal Operating Pressure (at the power supply outlet)	1500 psi (103 bar)	1500 psi (103 bar)	1500 psi (103 bar)	1500 psi (103 bar)
System relief valve setting (at the power supply outlet)	2100-2250 psi (145-155 bar)	2100-2250 psi (145-155 bar)	2200-2300 psi (152-159 bar)	2100-2250 psi (145-155 bar)
Maximum back pressure (at tool end of the return hose)	250 psi (17 bar)	250 psi (17 bar)	250 psi (17 bar)	250 psi (17 bar)
Measured at a max. fluid viscosity of: (at min. operating temperature)	400 ssu* (82 centistokes)	400 ssu* (82 centistokes)	400 ssu* (82 centistokes)	400 ssu* (82 centistokes)
Temperature: Sufficient heat rejection capacity to limit max. fluid temperature to: (at max. expected ambient temperature)	140° F (60° C)	140° F (60° C)	140° F (60° C)	140° F (60° C)
Min. cooling capacity at a temperature difference of between ambient and fluid temps	3 hp (2.24 kW) 40° F (22° C)	5 hp (3.73 kW) 40° F (22° C)	6 hp (5.22 kW) 40° F (22° C)	7 hp (4.47 kW) 40° F (22° C)
NOTE: Do not operate the tool at oil temperatures above 140° F (60° C). Operation at higher temperatures can cause operator discomfort at the tool.				
Filter Min. full-flow filtration Sized for flow of at least: (For cold temp. startup and max. dirt-holding capacity)	25 microns 30 gpm (114 lpm)	25 microns 30 gpm (114 lpm)	25 microns 30 gpm (114 lpm)	25 microns 30 gpm (114 lpm)
Hydraulic fluid Petroleum based (premium grade, anti-wear, non-conductive) Viscosity (at min. and max. operating temps)	100-400 ssu*	100-400 ssu* (20-82 centistokes)	100-400 ssu*	100-400 ssu*
NOTE: When choosing hydraulic fluid, the expected oil temperature extremes that will be experienced in service determine the most suitable temperature viscosity characteristics. Hydraulic fluids with a viscosity index over 140 will meet the requirements over a wide range of operating temperatures.				
*SSU = Saybolt Seconds Universal				

EHTMA HYDRAULIC SYSTEM REQUIREMENTS

CLASSIFICATION



Flow Range	3.5-4.3 gpm (13.5-16.5 lpm)	4.7-5.8 gpm (18-22 lpm)	7.1-8.7 gpm (27-33 lpm)	9.5-11.6 gpm (36-44 lpm)	11.8-14.5 gpm (45-55 lpm)
Nominal Operating Pressure (at the power supply outlet)	1870 psi (129 bar)	1500 psi (103 bar)	1500 psi (103 bar)	1500 psi (103 bar)	1500 psi (103 bar)
System relief valve setting (at the power supply outlet)	2495 psi (172 bar)	2000 psi (138 bar)	2000 psi (138 bar)	2000 psi (138 bar)	2000 psi (138 bar)

NOTE: These are general hydraulic system requirements. See tool specification page for tool specific requirements

OPERATION

PREOPERATION PROCEDURES

CHECK HYDRAULIC POWER SOURCE

1. Using a calibrated flowmeter and pressure gauge, check that the hydraulic power source develops a flow of 4-6 gpm/15-23 lpm at 1500-2000 psi/106-140 bar. For TT46233 Model, 7-10 gpm/26-38 lpm.
2. Make certain the hydraulic power source is equipped with a relief valve set to open at 2200-2300 psi/152-159 bar minimum. Maximum full flow pressure not to exceed 2500 psi/172 bar.

INSTALL TOOL BIT

1. Remove the two capscrews that hold the bit keeper to the lower body or on some models remove the two hex head capscrews, outer springs, and nuts that hold the bit keeper to the lower body.
2. Remove the two pair of bit-retaining spring guides and spring or on some models the one pair of bit guides from the bit keeper.
3. Insert the hex end of the bit as far as possible through the small end of the bit keeper (see parts list illustration).
4. Install the coil spring on the bit hex flange. Install a spring guide pair on each end of the spring. On some models only the one pair of bit guides need to be installed and **no** spring.

Note: There are two types of spring guides. Each of the two types must be installed in matched pairs. The pair used at the top of the spring have a flat end that goes against the bit collar.

Carefully install the bit keeper so that the lower spring guide fits into the lower keeper bore and that the upper flat end of the guide rests against the bit flange.

5. With the bit pulled down into the keeper, insert into the tie tamper hex, then press the bit keeper up against the lower body.
6. Tighten both capscrews or on some models install the hex head capscrews, outer springs, and nuts and tighten securely.

CONNECT HOSES

1. Wipe all hose couplers with a clean lint-free cloth before

making connections.

2. Connect the hoses from the hydraulic power source to the tool fitting or quick disconnects. It is a good practice to connect the return hose first and disconnect it last to minimize or avoid trapped pressure within the tool.
3. If hose couplers are used, observe flow indicators stamped on hose couplers to be sure that oil will flow in the proper direction. The female coupler is the inlet (pressure) coupler.

NOTE:

The pressure increase in uncoupled hoses left in the sun may result in making them difficult to connect. When possible, connect the free ends of operating hoses together.

TOOL OPERATION

1. Observe all safety precautions.
2. Install the appropriate tool bit for the job if not already installed.
3. Place the tamper on the surface to be compacted.

WARNING

The Tamper will rise quickly when first turned on. Do not stand over or place any part of your body on top of the tamper. Wear safety shoes.

Note:

Partially pressing the trigger allows the tool to run at slow speed, making it easier to start or control.

5. Guide the tamper using both hands.

COLD WEATHER OPERATION

If the tie tamper is to be used during cold weather, preheat the system hydraulic fluid at low engine speed.

When using the normally recommended fluids, oil fluid temperature should be at or above 50° F/10° C (400 ssu/82 centistokes) before use.

Damage to the hydraulic system or tie tamper can result from use with oil that is too viscous or thick.

TOOL PROTECTION & CARE

NOTICE

In addition to the Safety Precautions found in this manual, observe the following for equipment protection and care.

- Make sure all couplers are wiped clean before connection.
- The hydraulic circuit control valve must be in the “OFF” position when coupling or uncoupling hydraulic tools. Failure to do so may result in damage to the quick couplers and cause overheating of the hydraulic system.
- Always store the tool in a clean dry space, safe from damage or pilferage.
- Make sure the circuit PRESSURE hose (with male quick disconnect) is connected to the “IN” port. The circuit RETURN hose (with female quick disconnect) is connected to the opposite port. Do not reverse circuit flow. This can cause damage to internal seals.
- Always replace hoses, couplings and other parts with replacement parts recommended by Stanley Hydraulic Tools. Supply hoses must have a minimum working pressure rating of 2500 psi/172 bar.
- Do not exceed the rated flow (see Specifications) in this manual for correct flow rate and model number. Rapid failure of the internal seals may result.
- Always keep critical tool markings, such as warning stickers and tags legible.
- Tool repair should be performed by experienced personnel only.
- Make certain that the recommended relief valves are installed in the pressure side of the system.
- Do not use the tool for applications for which it was not intended.

TROUBLESHOOTING

If symptoms of poor performance develop, the following chart can be used as a guide to correct the problem. When diagnosing faults in operation of the wrench, always check that the hydraulic power source is supplying the correct hydraulic flow and pressure to the tool as listed in the following table. Use a flow meter known to be accurate. Check the flow with the hydraulic fluid temperature at least 80° F/27° C.

SYMPTOM	CAUSE	SOLUTION
Tie tamper does not run.	Power unit not functioning.	Check power source for proper flow and pressure, 4-6 gpm/14-23 lpm, 1500-2000 psi/106-140 bar. TT46233 Model, 7-10 gpm/26-38 lpm.
	Couplers or hoses blocked.	Remove restriction.
	Pressure and return line hoses reversed at ports.	Be sure hoses are connected to their proper ports.
	Mechanical failure of piston or automatic valve.	Disassemble tamper and inspect for damaged parts.
Tie Tamper does not run effectively.	Power unit not functioning.	Check power source for proper flow and pressure, 4-6 gpm/14-23 lpm, 1500-2000 psi/106-140 bar. TT46233 Model, 7-10 gpm/26-38 lpm.
	Couplers or hoses blocked.	Remove restriction.
	Low accumulator charge (pressure hoses will pulse more than normal).	Recharge accumulator. Replace diaphragm if charge loss continues.
	Oil too hot (above 140°F/60°C).	Provide cooler to maintain proper oil temperature (140°F/60°C).
Tie Tamper operates slow.	Low gpm supply from power unit.	Check power source for proper flow and pressure, 4-6 gpm/14-23 lpm, 1500-2000 psi/106-140 bar. TT46233 Model, 7-10 gpm/26-38 lpm.
	High back-pressure.	Check hydraulic system for excessive back-pressure (over 200 psi/14 bar).

CHARGING THE ACCUMULATOR

CHARGING THE ACCUMULATOR

To check or charge the accumulator the following equipment is required:

- Accumulator tester (Part Number 02835).
- Charging assembly (Part Number 15304) (includes a gauge w/snub valve, hose and fitting).
- NITROGEN bottle with a 800 psi/56 bar minimum charge.

1. On charge valves containing 5/8 inch hex locking nuts, first loosen the locking nut 1-1/2 turns.
2. Holding the chuck end of the Stanley tester (p/n 02835), turn the gauge fully counterclockwise to ensure the stem inside the chuck is completely retracted.
3. Thread the tester onto the charging valve of the tool accumulator (do not advance the gauge-end into the chuck end. Turn as a unit). Seat the chuck on the accumulator charging valve and hand tighten only.
4. Advance the valve stem by turning the gauge- end clockwise.
5. Connect the charge fitting on the hose to the charge valve on the 02835 Tester.
6. With the gauge and snub valve attached to the nitrogen bottle, and with the snub valve closed, open the nitrogen bottle valve.

NOTE:

It may be necessary to adjust the charge at 650-700 psi/45-48 bar to overcome any pressure drop through the charging system.

7. While watching the pressure gage open the snub valve allowing the gauge to read 600 to 700 psi/42 to 48 bar, close the snub valve on the charging assembly and also on the nitrogen bottle, remove the charging assembly from the accumulator tester.
8. Turn the gauge end of the tester fully counterclockwise to retract the plunger in the chuck. Then remove the tester from the charge valve.
9. On charge valves containing 5/8 inch hex locking nuts, tighten the locking nut.

TESTING THE ACCUMULATOR PRESSURE

1. Follow instructions 1 through 4 under "CHARGING THE ACCUMULATOR".
2. Read the pressure on the gauge (pressure should be between 500 & 600 psi/35 & 42 bar).
3. If the pressure is low, recharge the tool.

CHARGING THE ACCUMULATOR

Charge Location on TT46113, TT46113C, TT46133, TT46133B, TT46133C, TT46133UP and TT46233

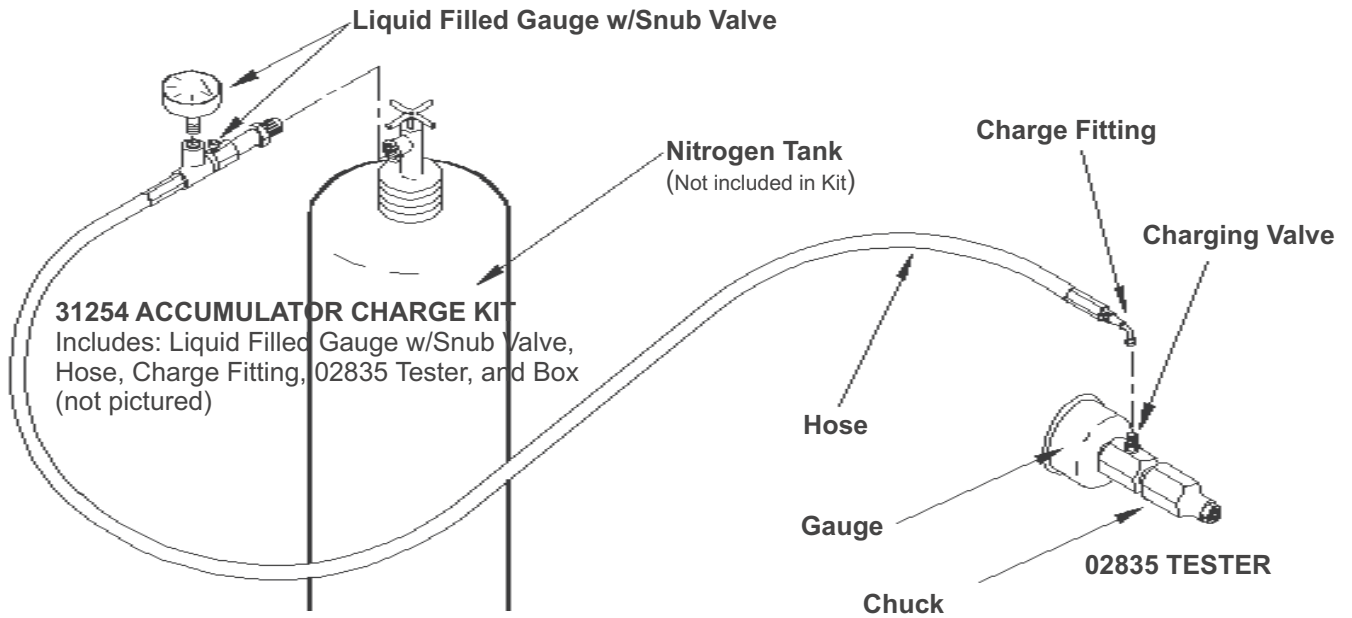
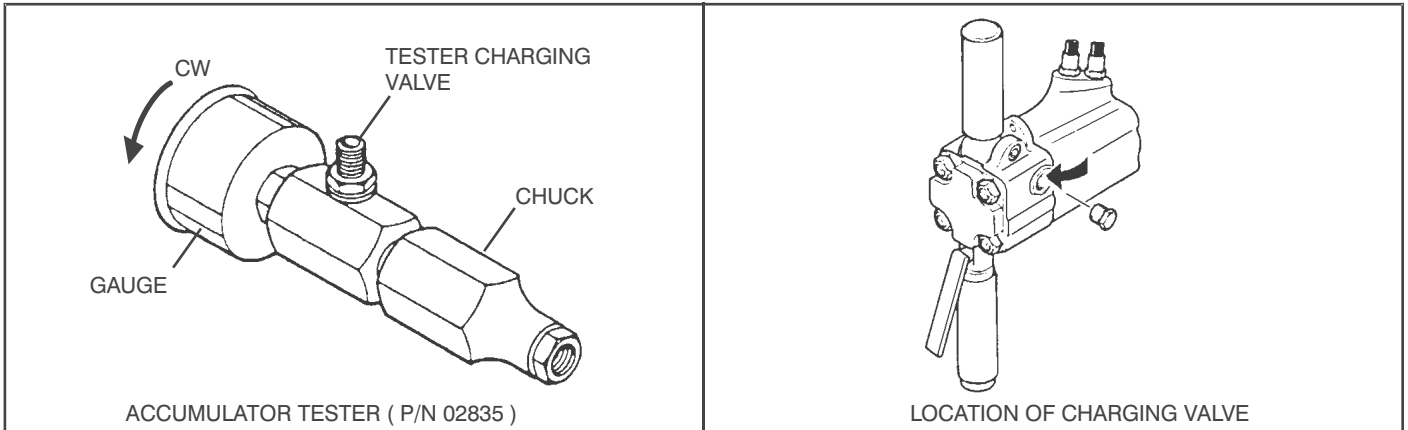

Charge Location on TT4611204 and TT4611206

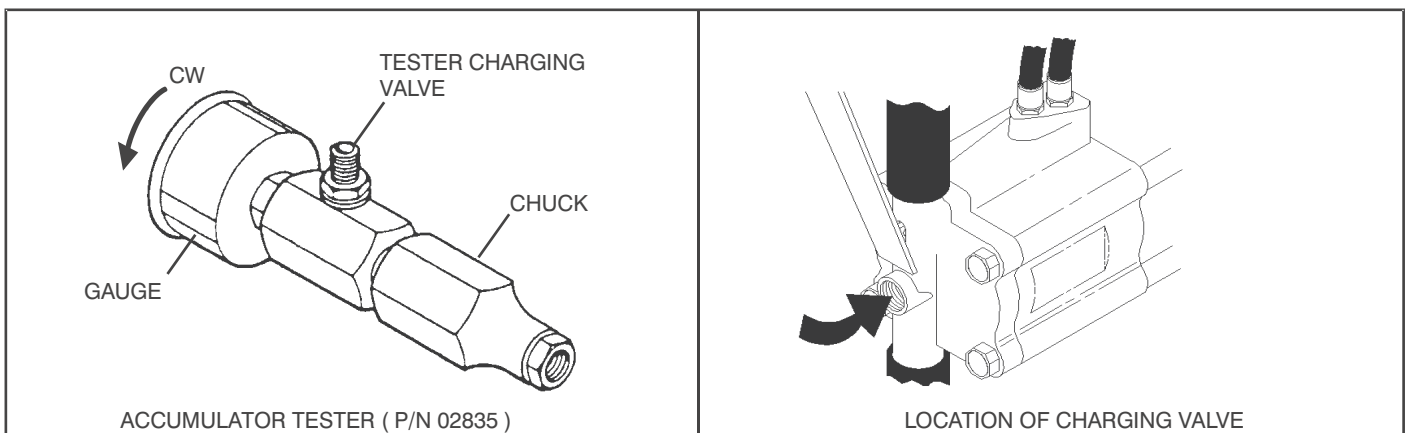

SPECIFICATIONS

SPECIFICATIONS

Pressure Range.....	1500-2000 psi / 106-140 bar
Maximum Back Pressure.....	200 psi / 14 bar
Flow Range	4-6 gpm / 15-23 lpm
Optimum Flow	5 gpm/20 lpm
Porting	-8 SAE O-ring
Connect Size and Type	3/8 in. Male Pipe Hose Ends
Connector	HTMA Flush Faced Coupler
Hose Whips	Yes
System Type.....	EHTMA Category C/HTMA Type I - Open Center
Weight (Rigid "T" Handle model w/Steel)	54 lb / 24 kg
(Anti-Vibration model w/Steel).....	56 lb / 25 kg
Overall Length (Rigid "T" Handle model w/Steel).....	38.75 inches / 98.4 cm
(Antivibration model w/Steel).....	39.75 inches / 100.9 cm
Overall Width (Rigid/Anti-Vibr. models)	14/17 inches / 35.6/44 cm

SOUND POWER AND VIBRATION DECLARATION

Test conducted on BR4056801 (same as TT46),operated at standard 5 gpm input.....	
Measured A-weighted sound power level, Lwa (ref. 1pW) in decibels	106 dBA
Uncertainty, Kwa, in decibels.....	3 dBA
Guaranteed sound power level.....	109 dBA
Measured A-weighted sound pressure level, Lpa (ref. 20 µPa) at operator's position, in decibels	98 dBA
Uncertainty, Kpa, in decibels	3 dBA
Values determined according to noise test code given in ISO 15744, using the basic standard ISO3744	
4	Test conducted by independent notified body to comply with 2000/14/EC:2005 requirements.
NOTE- The sum of a measured noise emission value and its associated uncertainty represents an upper boundary of the range of values which is likely to occur in measurements.....	
Declared vibration emission value in accordance with EN 12096.....	
Measured vibration emission value: 3-Axis	6.3 m/sec ²
Uncertainty: K.....	1 m/sec ²
Measured vibration emission value: Z-Axis.....	3 m/sec ²
Uncertainty: K.....	0.7 m/sec ²
Values determined according to ISO 8662-5, ISO 5349-1,2	

ACCESSORIES

Tie Tamper Steel 4 inch w/"V" Cut (18 inch OAL).....	44979
Tie Tamper Steel 4 inch w/"V" Cut (18 inch OAL) Heavy Duty.....	59034
Tie Tamper Steel 4 inch w/"V" Cut (21 inch OAL).....	44937
Tie Tamper Steel 4 inch w/"V" Cut (21 inch OAL) Heavy Duty	59033
Tie Tamper Steel 4 inch (24 inch OAL).....	33200
Pre-assembled Anti-Vibration Handle Conversion Kit	27680

SERVICE TOOLS

Tamping Sleeve Tool	01120
O-Ring Tool Kit	04337
Flow Sleeve Removal Tube.....	04910
Flow Sleeve Removal Tool	04919
Accumulator Cylinder Puller	05640

TEST EQUIPMENT

Accumulator Tester.....	02835
Accumulator Charge Kit (Includes Gauge w/Snub Valve, Hose, Charge Fitting, and Accumulator Tester	31254
Charging Assembly (Includes Gauge w/Snub Valve, Hose, and Charge Fitting).....	15304
Flow and Pressure Tester.....	04182

TT46113/133/233 PARTS ILLUSTRATION

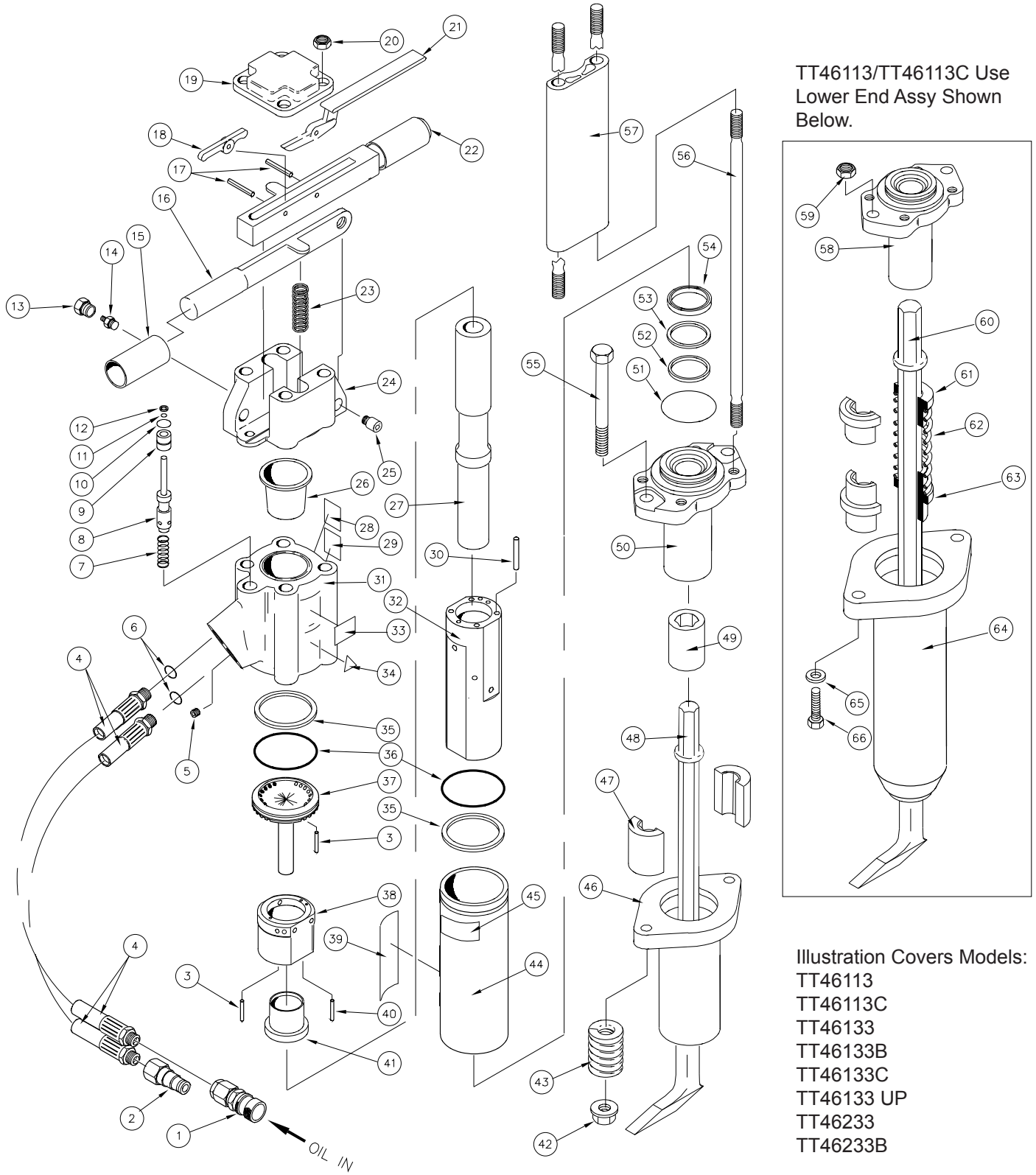

TT46113/TT46113C Use Lower End Assy Shown Below.

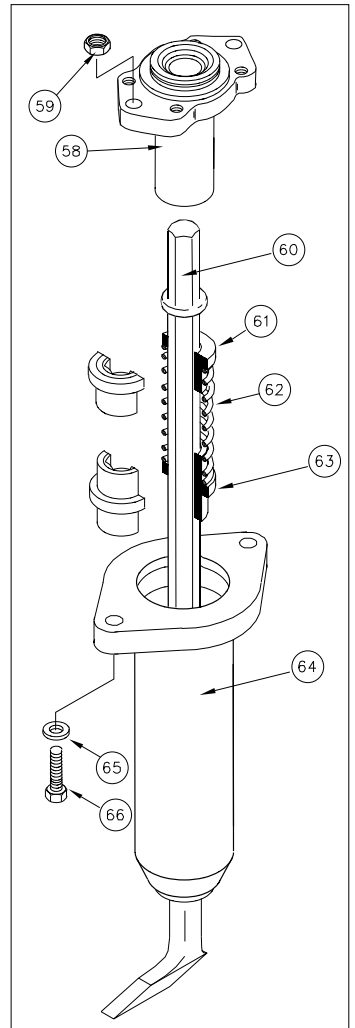

Illustration Covers Models:
 TT46113
 TT46113C
 TT46133
 TT46133B
 TT46133C
 TT46133 UP
 TT46233
 TT46233B

TT46113/133/233 PARTS LIST

Item	Part No.	Qty	Description
1	03972 47436	1	Female Coupler (Parker) Female Coupler (Aeroquip)
2	03973 47437	1	Male Coupler (Parker) Male Coupler (Aeroquip)
3	02900	2	Roll Pin
4	56725 66727	2	Hose Assy (Parker) Hose Assy (Aeroquip)
5	12832	1	Orifice Plug
6	01605	2	O-Ring (Incl with Item 4)
7	04058	1	Spring
8	20515	1	Valve Spool
9	04057	1	Bushing
10	00293	1	O-Ring
11	01362	1	O-Ring
12	04056	1	Rod Wiper
13	07493	1	Plug
14	20499	1	Charge Valve
15	02494	2	Handle Grip
16	28369	1	Handle
17	20500	2	Spirol Pin
18	20511	1	Lever
19	28494	1	Top Plate
20	04374	4	Locknut
21	20502	1	Trigger
22	29045	1	Trigger Handle
23	20498	2	Spring
24	20505	1	Handle Pivot
25	20508	2	Pivot Screw
26	07479	1	Accumulator Diaphragm
27	12833 04385	1	Piston Piston (TT46233 & 233B Only)
28	17784 07589	1	Sound Power Level Sticker (CE Models Only) GPM Sticker (TT46113, TT4612303 Only)
29	28409	1	Composite Sticker
30	04605	4	Push Pin
31	11588	1	Accumulator Charge Block
32	07485 04384	1	Flow Sleeve Flow Sleeve (TT46233 & TT46233B Only)
33	28322	1	CE Sticker
34	11206	1	Circuit Type C Sticker (CE Only)
35	04381	2	Backup Ring
36	04379	2	O-Ring
37	04378	1	Porting Block
38	07480 04380	1	Automatic Valve Body Automatic Valve Body (TT46233 & TT46233B Only)
39	23230 65049	1	Name Tag Name Tag (TT46233 & TT46233B Only)
40	04571	2	Push Pin

Item	Part No.	Qty	Description
41	04382	1	Automatic Valve
42	12307	2	Nut
43	12148	2	Spring
44	04383	1	Flow Sleeve Tube
45	25610	1	Railroad Help Desk Sticker
46	32258	1	Bit Keeper
47	32249	1	Bit Guide (Pair) Hex Shank
	38008		Bit Guide (Pair) Round Shank (TT46133/133B/ 133C/133UP/ TT46233/TT46233B Only)
48	44937 59033	1	Tie Tamper Bit Tie Tamper Bit (TT46133/ TT46233/TT46233B Only)
	15400		Hex Bushing
50	31955 65046	1	Lower Body Lower Body (TT46233 & TT46233B Only)
	02022		O-Ring
52	04387	1	Rod Wiper
53	04780	1	Washer
54	04386	1	Cup Seal
55	25304	2	Capscrew
56	20517	4	Side Rod
57	29959	1	Filler
58	23147	1	Lower Body (TT46113/ TT46113C Only)
59	371500	2	ESNA Nut (TT46113/TT46113C Only)
60	44937	1	Tie Tamper Steel (TT46113/ TT46113C Only)
61	21028	1	Bit Retaining Top Spring (Guide Pair) (TT46113/TT46113C Only)
62	21029	1	Compression Coil Spring (TT46113/TT46113C Only)
63	15411	1	Bit Retaining Spring (Guide Pair) (TT46113/TT46113C Only)
64	22890	1	Bit Keeper Weldment (TT46113/ TT46113C Only)
65	371050	2	Washer (TT46113/TT46113C Only)
66	15630	2	Capscrew (TT46113/TT46113C Only)
	04595	1	SEAL KIT

Lower Body Assy Part No., 33037. Includes Items 49-50.

Tie Tamper Update Kit: Part No. 33038. Includes Items 42-43, 46-47, 49-55

Coupler Sets: Aeroquip 47438 / Parker 03971

TT46112 PARTS ILLUSTRATION

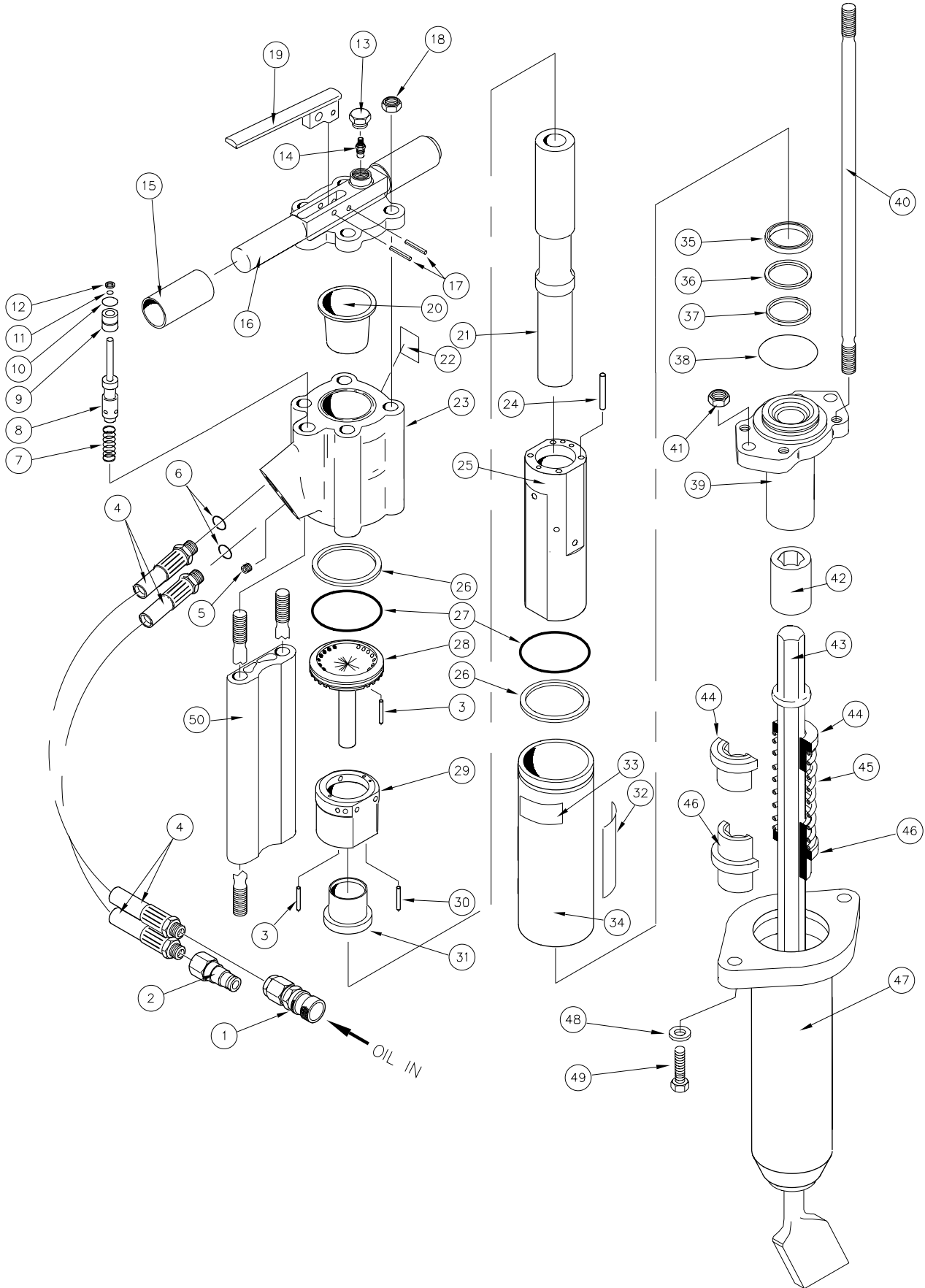

TT46112 PARTS LIST

Item	Part No.	Qty	Description
1	03972 47436	1	Female Coupler (Parker) Female Coupler (Aeroquip)
2	03973 47437	1	Male Coupler (Parker) Male Coupler (Aeroquip)
3	02900	2	Roll Pin
4	56725 66727	2	Hose Assy (Parker) Hose Assy (Aeroquip)
5	12832	1	Orifice Plug
6	01605	2	O-Ring (Incl with Item 4)
7	04058	1	Spring
8	04077	1	Valve Spool
9	04057	1	Bushing
10	00293	1	O-Ring
11	01362	1	O-Ring
12	04056	1	Rod Wiper
13	07493	1	Plug
14	20499	1	Charge Valve
15	02494	2	Handle Grip
16	07483	1	Handle
17	07492	2	Spirol Pin
18	04374	4	Locknut
19	04371	1	Trigger
20	07479	1	Accumulator Diaphragm
21	12833	1	Piston
22	07589	1	GPM Sticker
23	11588	1	Accumulator Valve Block
24	04605	4	Push Pin
25	07485	1	Flow Sleeve
26	04381	2	Backup Ring
27	04379	2	O-Ring
28	04378	1	Porting Block
29	07480	1	Automatic Valve Body
30	04571	2	Push Pin
31	04382	1	Automatic Valve
32	23230	1	Name Tag
33	25610	1	Railroad Help Desk Sticker
34	04383	1	Flow Sleeve Tube
35	04386	1	Cup Seal
36	04780	1	Washer
37	04387	1	Rod Wiper
38	02022	1	O-Ring
39	23147 33037	1	Lower Body Lower Body Assy (Incl Item 42)
40	04373	4	Side Rod
41	371500	2	ESNA Nut
42	15400	1	Hex Bushing
43	44937 44979	1	Tie Tamper Steel (TT46112 Only) Tie Tamper Steel (TT4611204 Only)

Item	Part No.	Qty	Description
44	21028	1	Bit Retaining Top Spring Guide (Pair)
45	21029	1	Compression Coil Spring
46	15411	1	Bit Retaining Top Spring Guide (Pair)
47	22890	1	Bit Keeper Weldment
48	371050	2	Washer
49	15630	2	Caspscrew
50	59959	1	Filler
	04595	1	SEAL KIT

STANLEY®

Stanley Hydraulic Tools
3810 SE Naef Road
Milwaukie, Oregon 97267-5698 USA
(503) 659-5660 / Fax (503) 652-1780
www.stanleyhydraulics.com