

STANLEY

Original instructions

ENG

A/17

Stanley MB/XP2015

HYDRAULIC BREAKER
User manual



Part Number: **OMMB/XP2015XENG.A17**

TABLE OF CONTENTS

OPERATION	3
Foreword	4
Machine numbers	6
Product introduction	7
Safety	14
Operation	24
LUBRICATION	41
Breaker tool greasing	42
Carrier hydraulic oil	48
MAINTENANCE.....	53
Routine maintenance	54
Changing the tool	57
Lower tool bushing.....	60
Troubleshooting.....	61
SPECIFICATIONS.....	67
Breaker specifications	68

OPERATION

FOREWORD

FOREWORD

Important safety information

Basic safety precautions are outlined in the "Safety" section of this manual and in the description of operations where hazards exist. Warning labels have also been put on the machine to provide instructions and to identify specific hazards which if not observed could cause bodily injury or death to you or other persons. These warnings in the guide and on the machine labels are identified by the warning symbol.

To use the attachment correctly, you must also be a competent operator of the carrier machine. Do not use or install it if you can not use the carrier machine properly. The attachment is a powerful tool. If used without proper care, it can cause damage.

Do not rush when you are learning to use the product. Take your time and most importantly, take it safely. Do not guess. If there is anything you do not understand, ask your local dealer.

Improper operation, lubrication or maintenance of this machine can be dangerous and could result in injury.

Do not operate this machine until you have read and understood the instructions in this manual.

Do not perform any lubrication and maintenance on this machine until you have read and understood the instructions in this manual.

Warranty

A complete warranty claim for a hydraulic breaker attachment includes at least the following information.

- Model and serial number
- Carrier model
- Installation: Oil flow, operating pressure and return line pressure if known
- Working hours and service history
- Application

Providing this information makes it easy to handle the warranty claim properly and swiftly.

Installation inspection

An installation inspection must be carried out after the product has been installed on the carrier. In the installation inspection certain specifications (such as operating pressure and oil flow) are checked so that they are within given limits. See "Breaker specifications" on page 68.

FOREWORD

Spare part orders

When you need spare parts or some information concerning maintenance to your machinery, please contact your local dealer. Quick deliveries are ensured by exact orders.

Required information:

1. Name of customer, contact person
2. Order number (when available)
3. Delivery address
4. Mode of delivery
5. Required delivery date
6. Invoicing address
7. Model and serial number of product
8. Name, number and required amount of spare parts
9. Certified Stanley purchase order

MACHINE NUMBERS

MACHINE NUMBERS

Model and serial number

The equipment serial number is stamped on the valve body. The model and serial number are also located on the CE marking. Check that the model corresponds to the one given on the cover of this manual.

It is important to make correct reference to the serial number of the attachment when making repairs or ordering spare parts. Identification of the serial number is the only proper means of maintaining and identifying parts for a specific product.

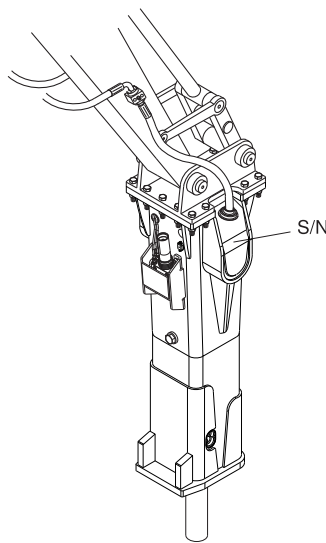

STANLEY	Stanley, 1538 Highway 2, Two Harbors, MN 55616 USA
Hydraulic Hammer	
Model:	XXXXX
Serial number:	XXXXXXXX
Hammer weight:	XXXXX lb
Min. working weight:	XXXXX lb
Operating pressure:	XXX - XXX bar
	XXX - XXX psi
Oil flow:	XXX - XXX lpm
	XXX - XXX gpm
Manufacturing date:	XX / XXXX
	Manufacturer: Sandvik Mining and Construction Oy Taivalkatu 8, 15170, Finland

ST010001

PRODUCT INTRODUCTION

PRODUCT INTRODUCTION

Overview

The product is a hydraulically operated hammer. It can be used on any carrier which meets the necessary hydraulic and mechanical installation requirements. The unit functions by repeatedly raising a steel piston and driving it down onto the head of a removable breaking tool.

No additional pressure accumulators are necessary since the integrated pressure accumulator absorbs hydraulic pressure peaks. The impact energy of the breaker is almost constant and independent of the carrier's hydraulic system.

Removal from package

Remove all the steel belts from the package. Open the package and remove all plastics covering the product.

Check that the product is in good condition and that there is no visible damage. Check that all ordered parts and accessories have been enclosed with the product. Some options may be provided by your local dealer like installation kits; including hoses and mounting bracket.

Lifting instructions

Use a hoist when lifting components which weigh 23 kg (50 lb) or more, to avoid back injury. Make sure all lifting equipment is in good condition and are in the correct capacity. Be sure hooks are positioned correctly. Lifting eyes are not to be side loaded during a lifting operation. Do not use the breaker's tools for lifting.

PRODUCT INTRODUCTION

Provided lifting points

Use the lifting eyes located on the product housing only to lift or handle the product itself. The lifting capacity calculation is based on the product's working weight including a normal working tool and an average sized mounting bracket.



Warning! To avoid falling objects, do not use the product to lift other products. Use the lifting eyes located on the product housing only to lift or handle the product itself.

The maximum allowed total weight is shown on the product's CE-plate and specification page. See "Breaker specifications" on page 68. If the weight exceeds the maximum allowed total weight shown on the CE-plate and specification page, you have to use other lifting points/methods than originally provided on the product.

The other threaded holes on the product (for example on the breaker impact unit) are intended for handling single parts only. It is forbidden to lift the entire assembly by using these threaded holes (for example on the cylinder outer surfaces). For handling the parts, see product workshop documentation for suitable lifting methods and lifting adapters.

Lifting eye screws

Tighten the lifting eye screws completely. Put a burden on the lifting eye only if the screw is properly tightened to the housing.



Failure to properly tighten the screw before allowing load pressure on the lifting eye may cause lifting eye to break and free fall of the product.

If you use mechanical tools for tightening, make sure not to overstrain the shank. Before lifting make sure that the chain and/or hook is stretched.

When two lifting eye screws are used, the lifting capacity depends on the angle of the lifting chains. The angle should not be less than 45°, as shown in the illustration. When the lifting eye screws are tightened, both rings should be aligned.

The loading capacity calculation applies to temperatures between -10 °C (14 °F) and 40 °C (104 °F).

Before reuse of lifting eye screws make sure there are no surface flaws (for example rust, pits, voids, folds and seams, deformation of the ring, or missing or broken threads).

The local, national safety standards for machines and lifting-equipments must always be strictly observed.

PRODUCT INTRODUCTION

Note: Before starting to operate the breaker, always replace the lifting eye with a blanking screw.

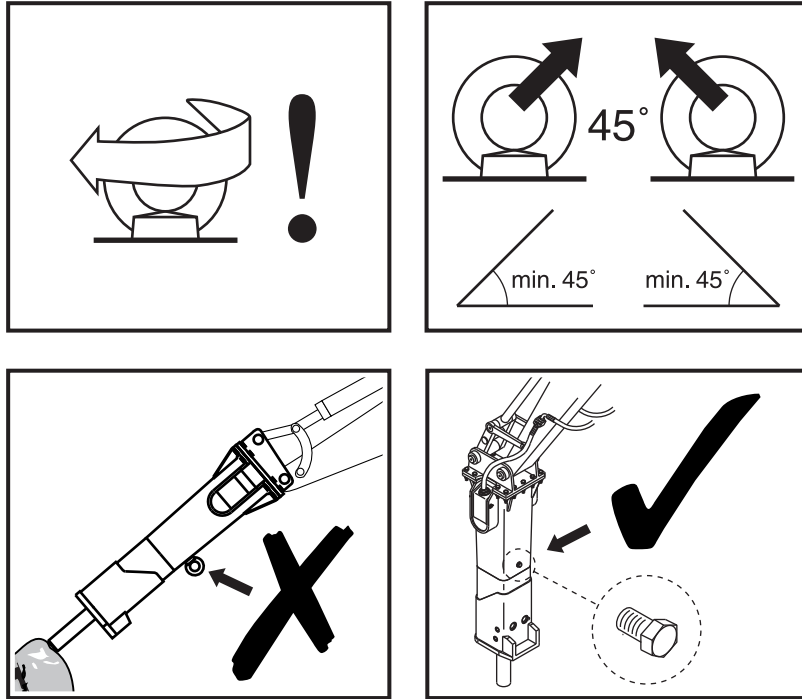

R010266

Lifting devices must safely carry the working weight of the product. See “Breaker specifications” on page 68. Place chains or slings, as shown by the illustration, to lift the product.

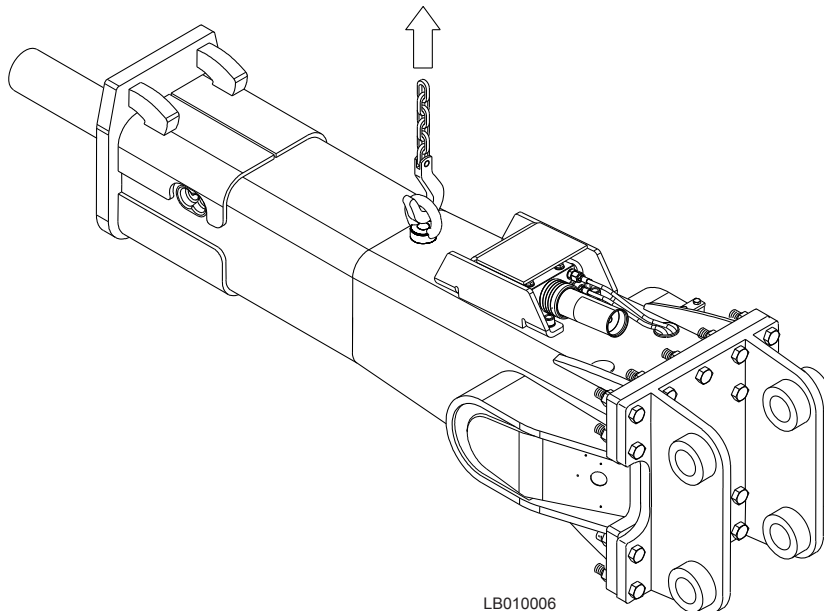

LB010006

Note: Before starting to operate the breaker, always replace the lifting eye with a blanking screw.

PRODUCT INTRODUCTION

Safety instructions for lifting

Below are some common safety instructions concerning lifting operations. In addition to this, the local, national standards for machines and lifting-equipments must always be strictly observed. Please note that the list below is not all inclusive, you must always ensure the procedure you choose is safe for you and others.

- Do not lift load over people. No one shall be under the hoisted load.
- Do not lift people and never ride the hoisted load.
- Keep people clear from lift area.
- Avoid side pull of the load. Make sure you take up the slack slowly. Start and stop carefully.
- Lift the load a few inches and verify it before proceeding. Make sure the load is well balanced. Check for any loose items.
- Never leave the suspended load unattended. Maintain load control at all times.
- Never lift the load over the rated capacity (see product's operating weight from specification page).
- Inspect all lifting equipment before use. Do not use twisted or damaged lifting equipment. Protect lifting equipment from sharp corners.
- Obey all local safety instructions.

PRODUCT INTRODUCTION

Main parts

The main parts of the breaker are shown below.

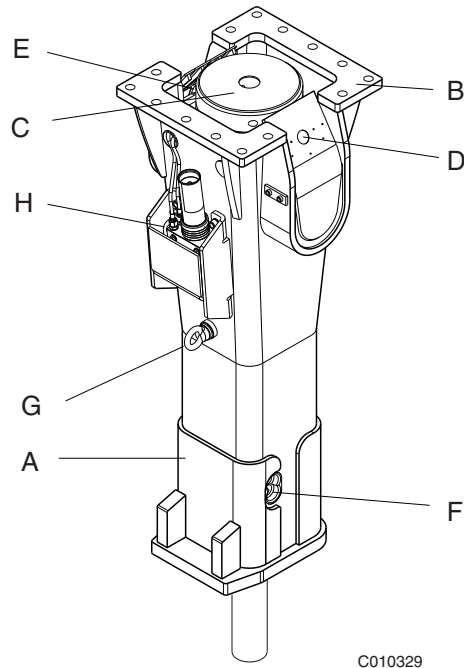

- A. Housing
- B. Mounting flange
- C. Vibration dampening elements
- D. Hose connections
(pressure and return lines, automatic lubrication and pressurized air)
- E. Pressure accumulator
- F. Tool retaining mechanism
- G. Lifting eye
- H. Greasing device/Grease zerks

PRODUCT INTRODUCTION

Restrictor valve

The hammer is equipped with a built-in restrictor valve (check the part number (X) from the parts manual).

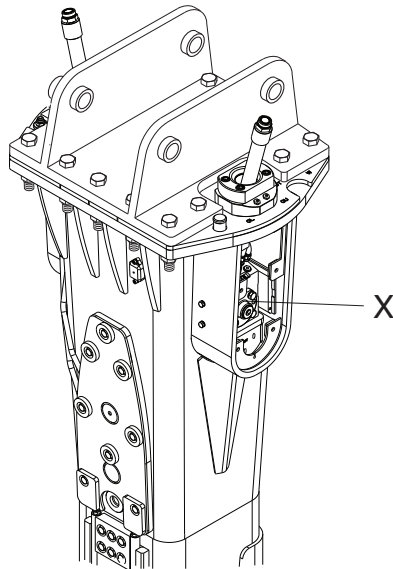

R010429

The restrictor valve is designed to decrease oil flow remarkably to the breaker when oil flow from the carrier is too high.

If the impact rate of the breaker decreases suddenly when operating the breaker, contact your local carrier dealer to decrease the carrier's oil flow.

Greasing device

The breaker can be equipped with an automatic greasing device. The tool grease is supplied from the greasing device into the breaker by the grease lines.

Advantages of the automatic lubrication system are:

- Longer service life for wear parts
- Higher utilization rate of the breaker
- Possibility to grease manually
- Reduced grease waste

Note: Some breaker models are equipped with an adapter kit for manual greasing and do not include an automatic greasing device.

PRODUCT INTRODUCTION

Service indicator

The SDC service indicator system is designed to help the breaker operators and service personnel in getting information about the service interval status, service history and accumulated working history of a breaker. Therefore the breaker serial number is always needed to complete service operations on the SDC device.

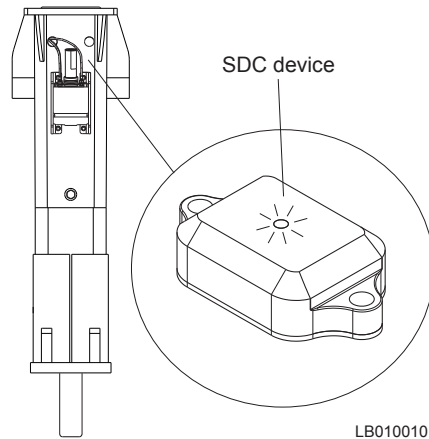

Possible operations with the SDC service indicator

- Checking the service interval status

SAFETY

SAFETY

General safety

All mechanical equipment can be hazardous if operated without due care or correct maintenance. Most accidents involving machine operation and maintenance are caused by failure to observe basic safety rules or precautions. An accident can often be avoided by recognizing potentially hazardous situations before an accident occurs.

Because it is impossible to anticipate every possible circumstance that might involve a potential hazard, the warnings in this guide and on the machine are not all inclusive. If a procedure, tool, working method or operating technique not specifically recommended by manufacturer is used, you must satisfy yourself that it is safe for you and others. You should also ensure that the product will not be damaged or made unsafe by the method of operation or maintenance procedures you choose.

Safety is not just a matter of responding to the warnings. All the time you are working with your attachment you must pay attention to what hazards there might be and how to avoid them. Do not work with the product until you are sure that you control it. Do not start any job until you are sure that you and those around you will be safe.



Warning! Read the following warning messages carefully. They tell you of different hazards and how to avoid them. If proper precautions are not taken you or others could be seriously injured.

SAFETY

Safety instructions

Manuals

Study this manual before installing, operating or maintaining the product. If there is anything you don't understand, ask your employer or your local dealer to explain it. Keep this manual clean and in good condition.

The related safety label on the breaker and the text on the label are shown below.

"IGNORING INSTRUCTIONS HAZARD

Faulty handling practice could cause death or serious injury.

Read and follow the instructions in the operator's manual."

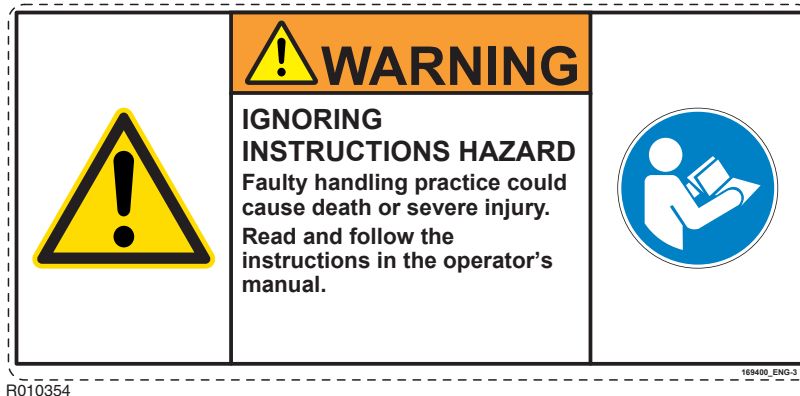

Care and alertness

All the time you are working with the product, take care and stay alert. Always be alert for hazards. The possibility of a serious or even fatal accident is increased when you are intoxicated.

Personal Protective Equipment

You can be injured if you do not wear proper Personal Protective Equipment (PPE). Loose clothing can get caught in the machinery. Wear PPE to suit the job.

Examples are: a safety helmet, safety shoes, safety glasses, well-fitting clothing, ear-protectors and industrial gloves. Keep cuffs fastened. Do not wear a necktie or scarf. Keep long hair restrained.

SAFETY

Practice

You and others can be killed or injured if you perform unfamiliar operations without practising them first. Practice away from the job site, in a clear area.

Keep other people away. Do not perform new operations until you are sure you can do them safely.

Regulations and laws

Obey all laws, work site and local regulations which affect you and your equipment.

Communications

Bad communications can cause accidents. Keep people around you informed of what you will be doing. If you will be working with other people make sure they understand any hand signals you will be using.

Work sites can be noisy. Do not rely only on spoken commands.

Work site

Work sites can be hazardous. Inspect the site before working on it.

Check for potholes, weak ground, hidden rocks and other possible hazards on the ground. Check for utilities (such as electric cables, gas and water pipes). Mark the positions of underground cables and pipes if you will be breaking the ground.

Poor visibility can cause accidents and damage. Make sure that visibility and lighting of the working area are adequate.

Banks and trenches

Banked material and trenches can collapse. Do not work too close to banks and trenches where there is a danger of collapse.

Safety barriers

Unguarded equipment in public places can be dangerous. Place barriers around the machine to keep people away.

SAFETY

Airborne pollutants

The related safety label on the breaker and the text on the label are shown below.

"DUST HAZARD

Breathing dust will cause death or severe injury.

Always wear approved respirator."



Airborne pollutants are microscopic particles, which will damage your health, when inhaled. Airborne pollutants on construction sites can be, for example, silica dust, oil fumes or diesel exhaust particles, visible or invisible. Especially in demolition sites, there may be other dangerous substances, such as asbestos or lead paints or other chemical substances.

The effect of airborne pollutants may be immediate if the substance is poisonous. The main danger with airborne pollutants comes from long term exposure, where particles are inhaled but not removed from the lungs. The disease is called silicosis, asbestosis or other, and will result in death or serious injury.

To protect yourself from airborne pollutants, always keep excavator doors and windows closed during operation. Excavators with pressurized cabins should be utilized in breaker operation. Proper maintenance of fresh air filters of the excavator is essential. Where pressurized cabins are not available, proper respirators must be utilized.

Stop working, when bystanders are in the area of airborne pollutants and make sure they have proper respirators. Respirators are as important for bystanders as hard hats.

Respirators for both operator and bystanders must be approved by the respirator manufacturer for the application in question. It is essential that the respirators protect from the tiny dust particles which cause silicosis and which may cause other serious lung diseases. You should not use the equipment until you are sure the respirators are working properly. This means the respirators must be checked to make sure that it is clean, that its filter has been changed, and to otherwise make sure the respirator will protect in the way it is meant to.

Always make sure dust has been cleaned off your boots and clothes when you leave your shift. The smallest particles of dust are the most harmful. They may be so fine that you can not see them. Remember, you **MUST** protect yourself and bystanders from the danger of breathing or inhaling dust.

Always follow local laws and regulations for airborne pollutants in the working environment.

SAFETY

Flying chips of rock

The safety label on the breaker is shown below:

"FLYING OBJECTS HAZARD

Fragments fly up to 40 m (130 ft) and could cause death or serious injury.

Stop operation when a person enters hazard zone.

Wear approved personal protective equipment."

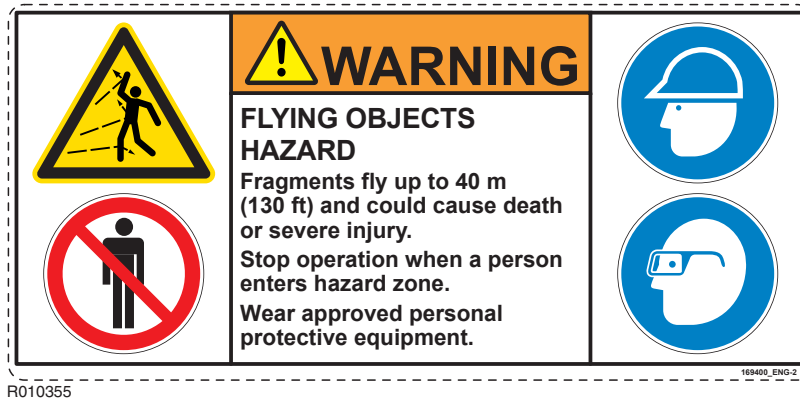

Protect yourself and your neighbourhood against flying chips of rock. Do not operate the product or carrier if someone is too close.

The ISO standard 20474-1 on safety of earth-moving machinery requires that adequate operator's protection, such as impact-resistant material, a mesh guard or an equivalent protection is used.

Keep the cabin windows and doors closed during operation. Window bars are recommended to protect the windows from flying chips of rock.

SAFETY

High noise level

A breaker in operation creates a high noise level. Always wear ear protection to prevent personal injury.

The safety label on the breaker is shown below:

"NOISE HAZARD

Continuous exposure to noise above 80 dB(A) will cause hearing impairment.

Wear approved hearing protectors."

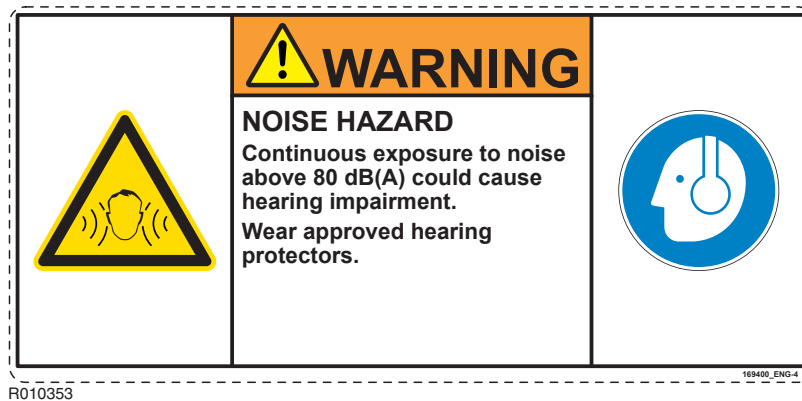

Equipment limits

Operating the product beyond its design limits can cause damage. It can also be dangerous. See "Breaker specifications" on page 68.

Do not try to enhance the product's performance by unapproved modifications.

Hydraulic fluid

Fine jets of hydraulic fluid at high pressure can penetrate the skin. Do not use your fingers to check for hydraulic fluid leaks. Do not put your face close to suspected leaks. Hold a piece of cardboard close to suspected leaks and then inspect the cardboard for signs of hydraulic fluid. If hydraulic fluid penetrates your skin seek medical attention immediately.

Hot hydraulic fluid can cause severe injuries.

Hydraulic hoses and fittings

Ensure all hydraulic components will withstand maximum pressure and mechanical stresses caused by operation of the attachment. Consult your local dealer for instructions.

SAFETY

Fire hazard

Most hydraulic fluids are flammable and might ignite when contacting hot surface. Avoid spilling hydraulic fluid to hot surfaces.

Working with the product on certain materials can cause sparks and hot splinters to get loose. These can ignite flammable materials around working area.

Ensure that adequate extinguisher is available.

Hydraulic pressure

Hydraulic fluid at system pressure can injure you. Before disconnecting or connecting hydraulic hoses, stop the carrier engine, operate the controls to release pressure trapped in the hoses and wait ten (10) minutes. During the operation, keep people away from the hydraulic hoses.

There might be pressurized oil trapped inside the product even if it is disconnected from the carrier. Be aware of possible blank firing while greasing or removing and installing breaker tools. See "Changing the tool" on page 57.

Pressure accumulators

The safety label on or near the accumulator is shown below.

"HIGH PRESSURE HAZARD

Improper handling of pressurized accumulator will cause death or severe injury.

Read workshop manual before disassembly.

Release pressure before disassembly.

Recharge with nitrogen (N₂) only."



The breaker incorporates one or two pressure accumulators, depending on the model. The accumulators are pressurized even when there is no hydraulic pressure to the breaker. Attempting to dismantle the accumulators without first releasing the pressure can cause injury or death. Do not try to dismantle pressure accumulators, contact your local dealer first.

SAFETY

Lifting equipment

You can be injured if you use faulty lifting equipment. Make sure that lifting equipment is in good condition. Make sure that the lifting equipment complies with all local regulations and is suitable for the job. Make sure that the lifting equipment is strong enough for the job and that you know how to use it.

Do not use this product or any of its parts for lifting. See “Lifting instructions” on page 7. Contact your carrier dealer to find out how to lift with your carrier.

Spare parts

Use only genuine spare parts. Use only genuine tools with hydraulic breakers. The use of other spare part or breaker tool brands may damage the product.

The use of other spare part or breaker tool brands may also void the warranty.

Equipment condition

Defective equipment can injure you or others. Do not operate equipment which is defective or has missing parts.

Make sure the maintenance procedures in this manual are completed before using the product.

Repairs and maintenance

Do not try to do repairs or any other maintenance work you do not understand.

Modifications and welding

Non-approved modifications can cause injury and damage. Contact your local dealer for advice before modifying the product. Before welding on the product while it is installed on the carrier, disconnect the carrier alternator and battery. Note that welding of the breaker tools will render them useless and make the warranty void.

Metal splinters

You can be injured by flying splinters when driving metal pins in and out. Use a soft-faced hammer or drifts to remove and fit metal pins, such as pivot pins. Always wear safety glasses.

SAFETY

Labels on the Product

Safety labels communicate the following four things:

- The severity level of the risk (that is, signal word "DANGER" or "WARNING").
- The nature of the hazard (such as high pressure, or dust).
- The consequence of interaction with the hazard.
- How to avoid the hazard.

You must ALWAYS follow the instructions of the safety messages and symbols of the product safety labels and the instructions set forth in the manuals to avoid death or severe injury!

Keep the safety labels clean and visible at all times. Check the condition of safety labels daily. Safety labels and instructions which have disappeared, been damaged, painted over, come loose or do not meet the legibility requirements for safe viewing distance, must be replaced before operating the product.

If a safety label is attached to a part that is replaced, install a new safety label on the replacement part. If this manual is available in your language, then the safety labels should be available in the same language.

There are several specific safety labels on this breaker. Please become familiarized with all safety labels. The location of the safety labels is shown in the illustration below.

When you clean the safety labels, use a cloth, water and soap. Do not use solvent, gasoline or other harsh chemicals to clean the safety labels.

Solvents, gasoline or harsh chemicals could loosen the adhesive that secures the safety labels. Loose adhesive will allow the safety label to fall.

SAFETY

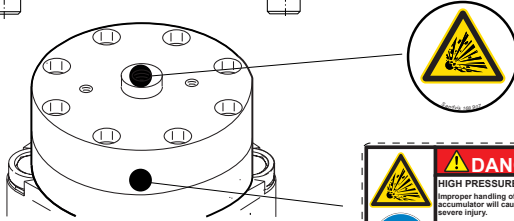
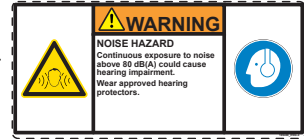
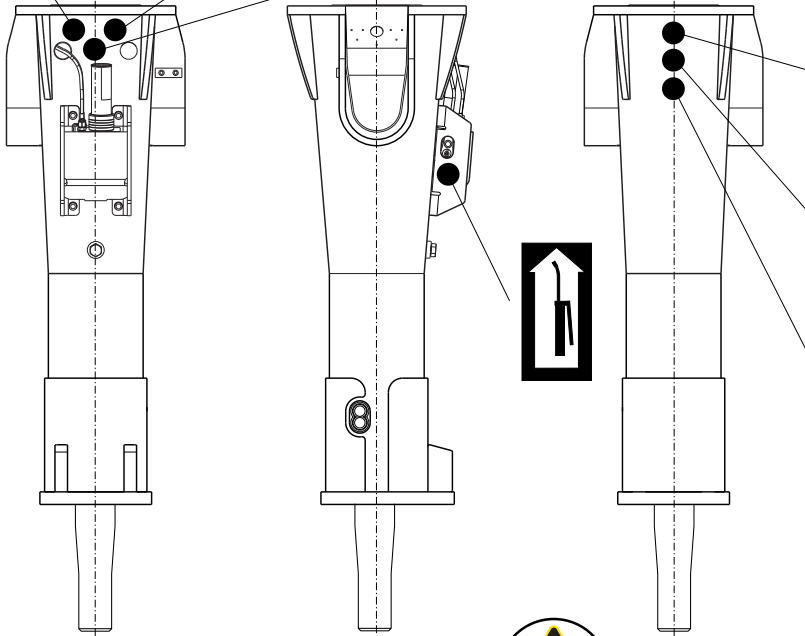
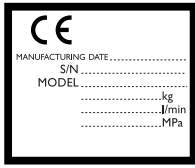

R010363

OPERATION

OPERATION

Operating instructions

Recommended use

The hammer is designed to be used in breaking concrete, road surface or asphalt, hard or frozen ground. It can be also used in breaking moderate sized boulders as well as in demolishing reinforced structures and for major excavation and clearing work. Your local dealer will gladly give you more information.

Operating conditions

Principle of installation

Almost all carriers meeting mechanical and hydraulic requirements can be used to operate the attachment. See “Breaker specifications” on page 68. The product is installed on the carrier much in the same manner as installing a bucket or other attachments. A flange mounted attachment requires a separate mounting bracket.

The attachment is connected to a carrier's hydraulic circuit with an installation kit. If the carrier is already equipped with an installation kit, the installation requires only suitable hoses and fittings. If the carrier does not have suitable kit to run the attachment, one must be built. This may require more complex installation including new piping and additional valves such as directional valve and pressure relief valve.

Suitable kits can be ordered from the manufacturer or local dealers, from carrier manufacturers and their dealers or from third party suppliers.

Hydraulic oil

In general the hydraulic oil originally intended for the carrier can be used with this product. See “Requirements for hydraulic oil” on page 48.

Operating temperature

The operating temperature is -20 °C (-4 °F) to 80 °C (176 °F). If the temperature is lower than -20 °C (-4 °F), the breaker and tool have to be preheated before any operations can begin, in order to avoid breaking the accumulator's membrane and the tool. During operation they will remain warm.

Note: The temperature of the hydraulic oil must be monitored. Ensure that oil grade and monitored oil temperature together guarantee correct oil viscosity. See “Oil specifications” on page 48.

OPERATION

Noise dampening

Operating the breaker near residential areas or other noise sensitive areas can cause noise pollution. In order to avoid unnecessary noise, please follow these basic rules:

1. When operating the breaker, keep the tool at a 90 degree angle to the material and the feed force in-line with the tool.
2. Replace or fix all parts that are worn out, damaged or loosened. This not only saves your breaker but it also decreases the noise level.

Principles of breaking

To increase the breaker's working life, pay particular attention to correct working methods and how to choose the correct tool for the job. There are essentially two ways of breaking with a hydraulic breaker.

Penetrative breaking (or cutting)

In this form of breaking a moil point or chisel tool is forced inside the material. This method is most effective in soft, layered or plastic, low abrasive material. The high impact rate of the small breakers makes them ideal for penetrative breaking.

Impact breaking

With impact breaking, the material is broken by transferring very strong mechanical stress waves from the tool into the material. Impact breaking is most effective in hard, brittle and very abrasive materials. The high impact energy of the big breakers makes them ideal for impact breaking. The best possible energy transfer between the tool and the object is achieved with a blunt tool. The use of a chisel tool in hard material will cause the sharp edge to wear very quickly.

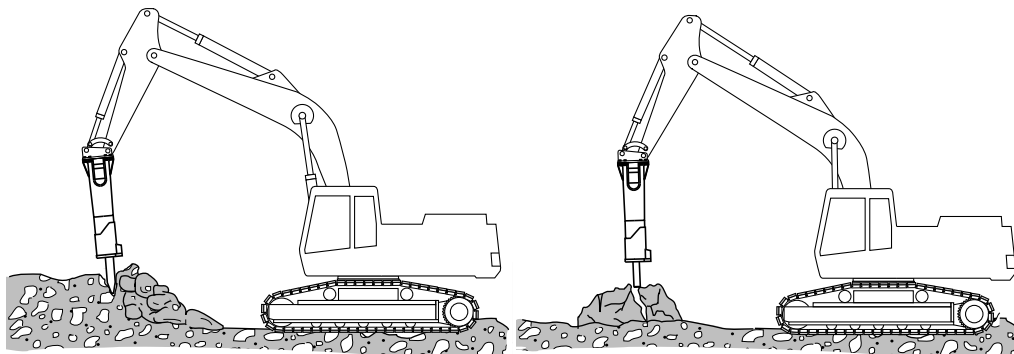

R010007

OPERATION

Choosing tools

Chisel, moil point and pyramid

- For sedimentary (e.g. sandstone) and weak metamorphic rock into which the tool penetrates.
- Concrete.
- Trenching and benching.

Blunt tool

- For igneous (e.g. granite) and tough metamorphic rock (e.g. gneiss) into which the tool doesn't penetrate.
- Concrete.
- Breaking boulders.

It is important to choose a tool, which is suitable for your breaker and for the application you are working on. The tool selection available depend on breaker model.

Checking the service interval status

You can check the service interval status by firmly tapping the sensor three (3) times in 1- to 3-second intervals. If the pulse is not timed correctly, you need to wait five seconds before trying again.

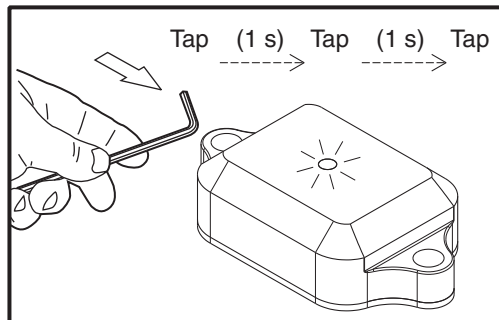

R010381

One (1) flash	Indicates that the breaker is operating at 0-25% of the service interval.
Two (2) flashes	Indicates that the breaker is operating at 25-50% of the service interval.
Three (3) flashes	Indicates that the breaker is operating at 50-75% of the service interval.
Four (4) flashes	Indicates that the breaker is operating at 75-100% of the service interval.
Five (5) flashes	Indicates that the service interval of the breaker is completed and the breaker must be serviced.

The sensor repeats the signal about every 20 seconds for the next four minutes. The status of the service interval should be checked weekly. It is also recommended that you keep a log of the status of the LED display.

OPERATION

Daily operation

General guidelines

- A safety screen is recommended to protect the operator from flying debris. Keep the cabin windows and doors closed during operation.
- Keep the tool at a 90 degree angle at all times. If the object moves or its surface breaks, correct the angle immediately. Keep the feed force and tool aligned.
- Keep the tool shank well greased during operation. Regular visual inspections during operation are recommended. An unlubricated tool shank requires more frequent greasing intervals. A tool shank covered with excessive grease requires less frequent greasing intervals.

R010023

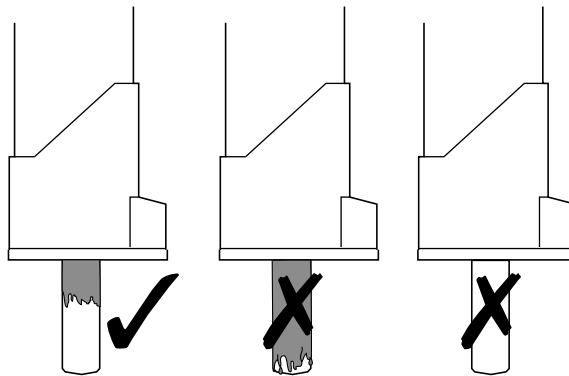

- To use the breaker most efficiently when breaking large objects, concentrate on small steps from the outer edge towards the middle.

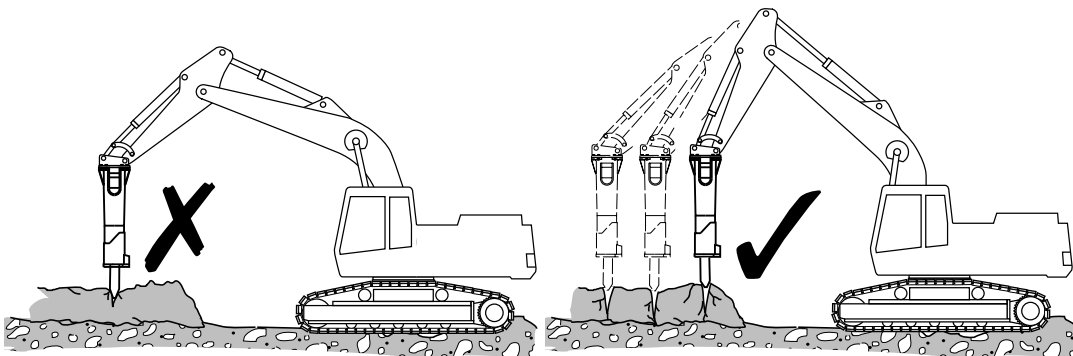

R010015

OPERATION

- Do not strike in one spot for more than 15 seconds at a time. If the object does not break, or if the tool does not penetrate, stop the breaker and change the position of the tool. Working too long in one spot will create stone dust under the tool. Dust dampens the impact effect and produces heat.

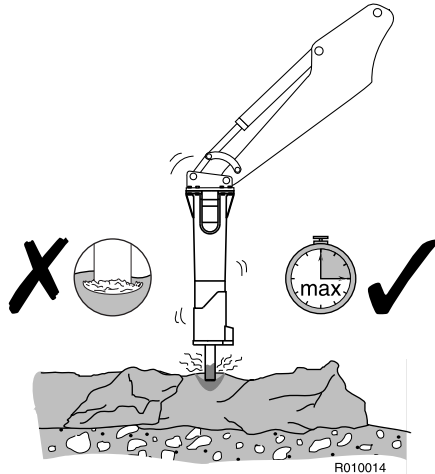

- Listen to the breaker's sound when you are using it. If the sound becomes weaker and the impact less efficient, the tool is misaligned with the material and/or there is not enough down force on the tool. Realign the tool and press the tool firmly against the material.
- Do not let the tool move outwards from the breaker when it penetrates. Keep the down-pressure on the breaker while breaking.
- When demolishing vertical structures (such as brick walls), place the tool against the wall at a 90 degree angle.
- When breaking concrete, hard or frozen ground, never strike and pry with the tool at the same time. The tool may break. Bending may be caused by stones inside hard or frozen ground. Be careful and stop striking if you find sudden resistance under the tool.
- When breaking hard or frozen ground, use the benching method. Start with clearing a small area from the edge. Then continue by breaking material towards the open area.
- Do not use the breaker tools to move rocks. The stone claws are designed for this purposes.

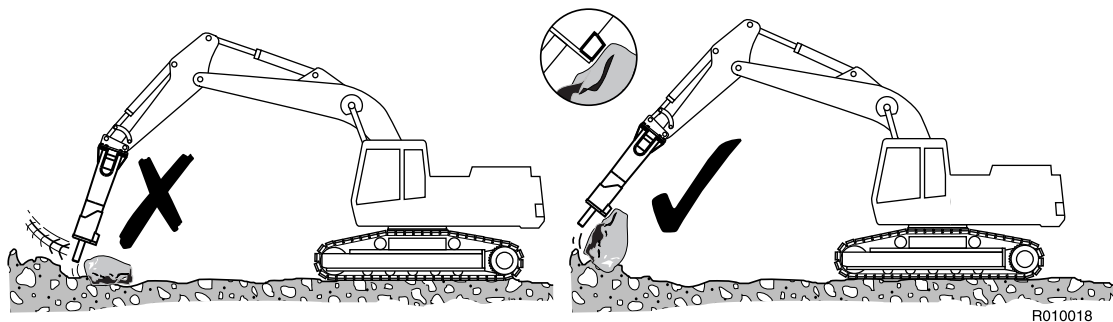

OPERATION

- Do not use the breaker to sweep the ground of debris. This may damage the breaker and the housing will wear out more quickly.

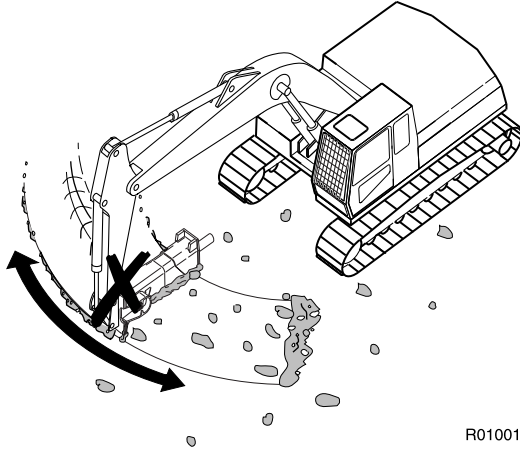

- When operating the breaker, make sure that it does not make contact with the carrier boom or hydraulic lines.

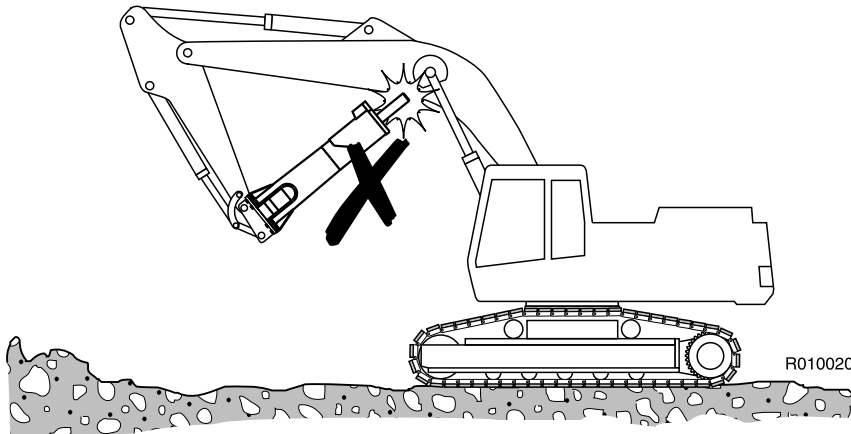

OPERATION

- Do not operate the breaker with the carrier's boom, stick or bucket cylinders at the end of their stroke (either fully extended or fully retracted). Damage to the carrier may result.

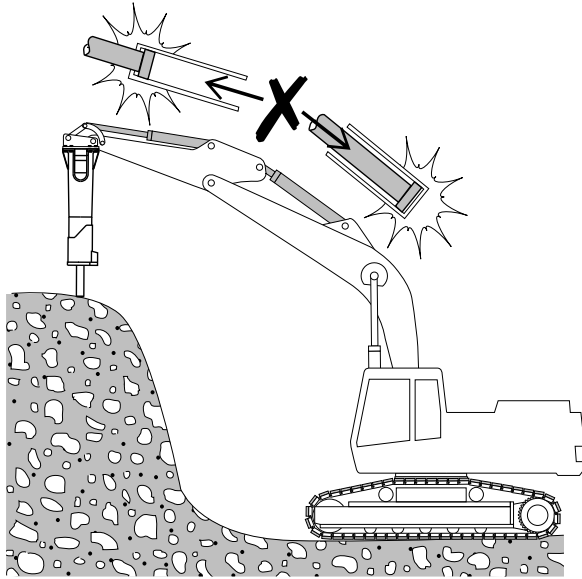

R010021

- Do not use the breaker or breaker tools for lifting. Lifting eyes on the breaker are for storage and maintenance purposes only.

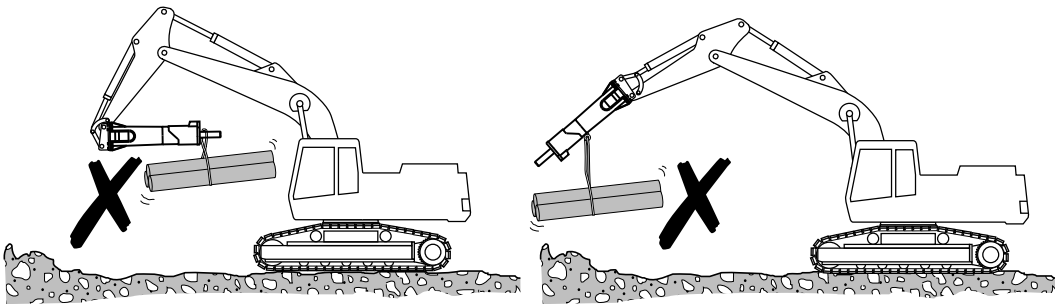

R010022

OPERATION

Working procedure



Warning! Protect yourself and your neighbourhood against flying chips of rock. Do not operate the breaker or carrier if someone is too close to the breaker.

Do not use the breaker, as a standard assembly, under water. If water fills the space where the piston strikes the tool, this generates a strong pressure wave that may damage the breaker.

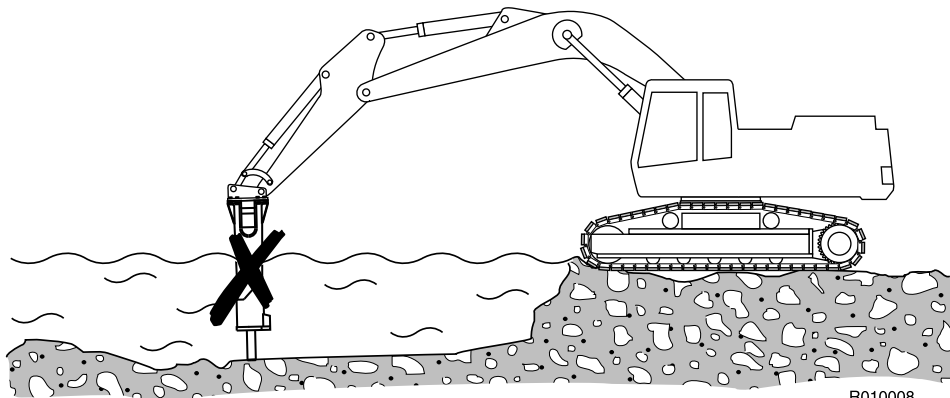

Warning! To avoid falling objects, do not use the product to lift other products. The lifting eyes located on the product housing are to be used solely to lift or handle the product itself. See “Lifting instructions” on page 7.

1. Prepare the carrier for normal excavation work. Move the carrier to the required position. Set the drive to neutral.
2. Set the engine speed to the recommended engine RPM for correct amount of oil supply.
3. Carefully operate the carrier controls to place the breaker and boom into the breaking position. Quick and careless boom movements can result in damage to the breaker.

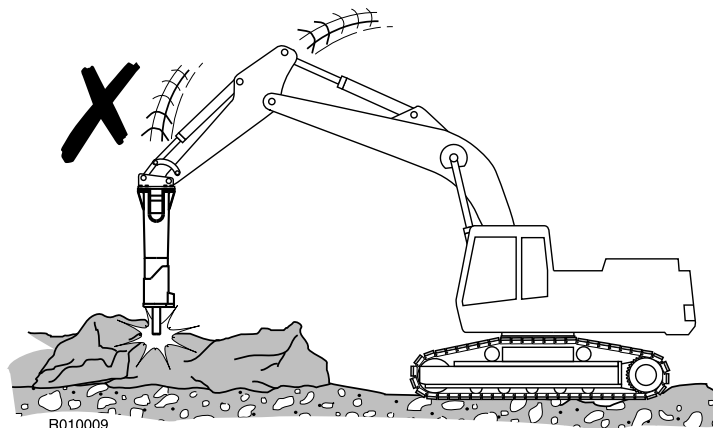

OPERATION

4. Use the excavator boom to press the breaker firmly against the object. Do not pry the breaker with the boom. Do not press too hard or too gently with the boom. The correct force is applied, when the tracks start to lift slightly from the ground.

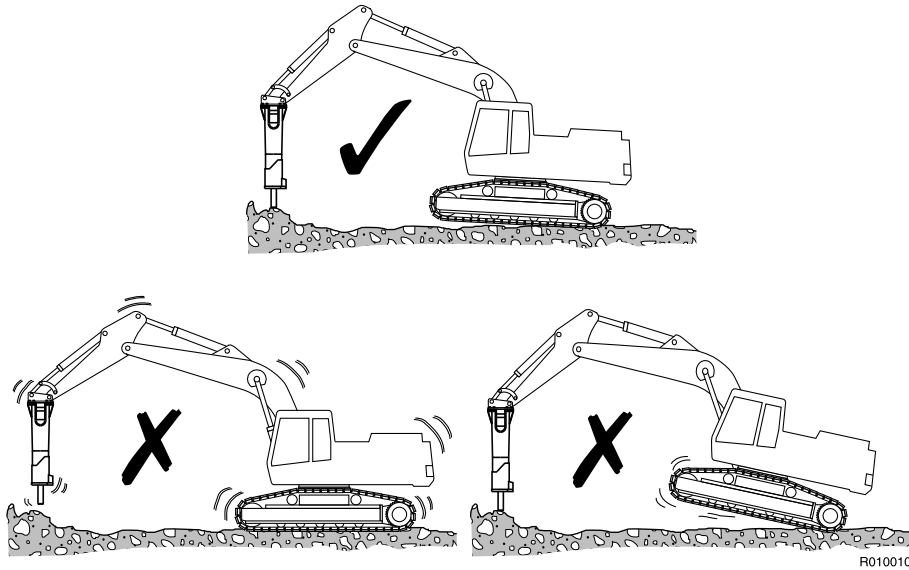

5. Place the tool against the object at a 90 degree angle. Avoid small irregularities on the object which will break easily and cause either idle strokes or an incorrect working angle.

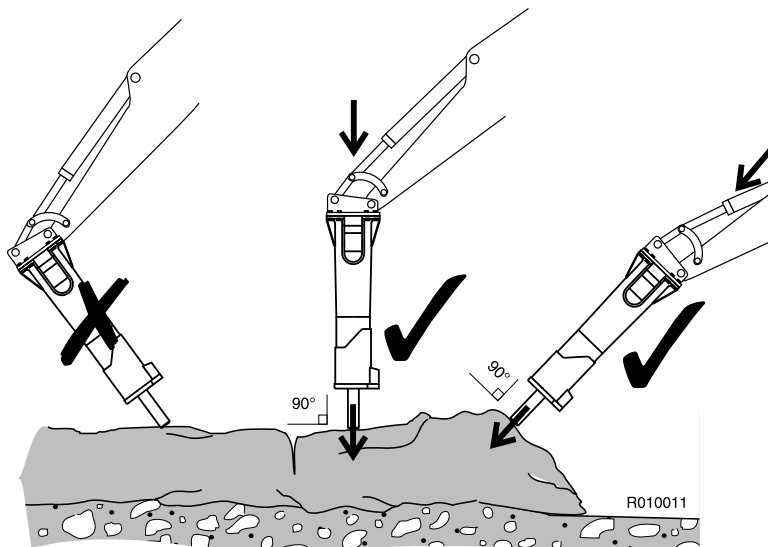

OPERATION

6. Start the breaker.
7. Stop the breaker quickly. Do not allow the breaker to fall down and make idle strokes when an object breaks. Frequent idle strokes have a deteriorating effect on the breaker. If the breaker falls through, the housing wears out more quickly.

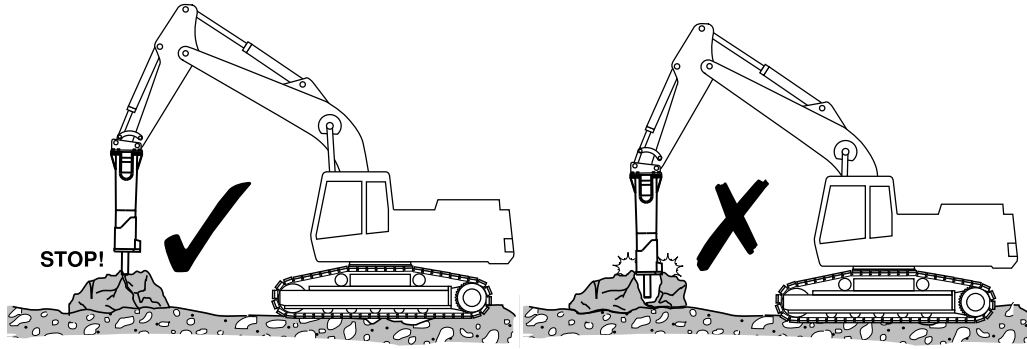

R010016

OPERATION

Mounting and dismantling the breaker

Removal from carrier



Warning! The breaker must be secured from rolling over when disconnecting from the carrier. Only use a skilled operator to position the carrier for breaker removal!

Warning! Hydraulic pressure inside the breaker must always be released before opening hose connections!

Warning! Hot hydraulic fluid can cause severe injuries!

1. Position hammer horizontally on the floor. If the breaker is going to service, remove the tool.
2. Stop the carrier engine. Operate boom and breaker controls to release pressure trapped inside hoses. Wait ten minutes for oil pressure to drop.
3. Close hammer inlet and outlet lines. If quick couplers are used, disconnection automatically closes breaker lines. If breaker line includes ball valves, please make sure that they are closed.
4. Disconnect hoses. **NOTICE! Protect environment from oil spills.** Plug the hoses and the breaker inlet and outlet ports to keep dirt out from hydraulic circuit.
5. Remove bucket pins and other parts.

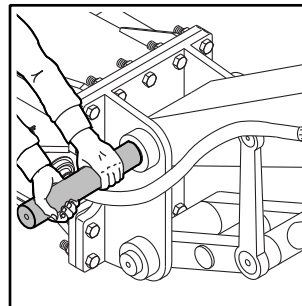
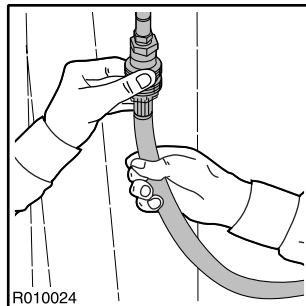

6. The carrier can be moved aside.

OPERATION

Installation

1. Install breaker in the same manner as mounting a bucket. Install bucket pins.
2. Connect hoses. Breaker inlet port is marked on the valve body with "IN" and outlet port with "OUT". An installation inspection must be carried out after the product has been mounted on the carrier. In the installation inspection certain specifications (such as operating pressure, oil flow) are checked so that they are within given limits. See "Breaker specifications" on page 68.
3. Open hammer inlet and outlet lines.

Turning breaker left- or right-handed

It is possible to make the breaker either left- or right-handed by turning the breaker inside the housing 180 degrees.



Warning! The hydraulic pressure inside the breaker must always be released before removing any of the plugs or valves. Read the instructions on releasing the hydraulic pressure from the breaker.

Warning! Hot hydraulic fluid can cause severe injuries!



Warning! The breaker must be secured from falling down in either direction when handling it. Check that the lifting capacity of the hoist you are using is sufficient for the job. See "Lifting instructions" on page 7. See "Breaker specifications" on page 68.

1. Remove the tool and disconnect the breaker from the carrier.
2. Remove cover out of way.
3. Disconnect hose couplings from breaker.

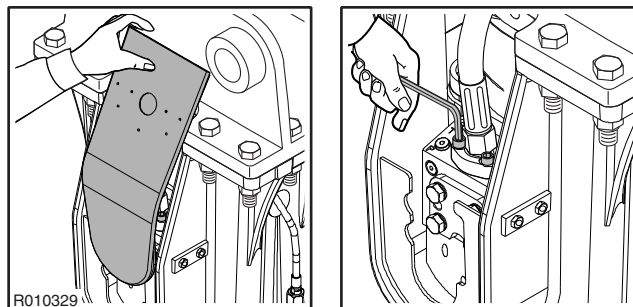

4. Open mounting bracket screws.
5. Lift mounting bracket off.

OPERATION

6. Remove buffer.

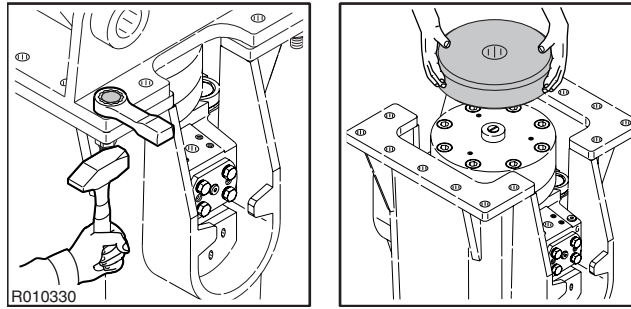

7. Disconnect grease hose and pressure hose from breaker.

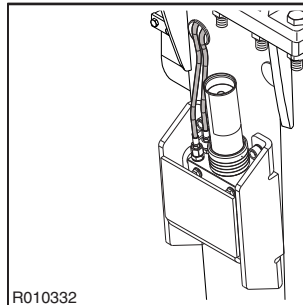

8. Install two lifting eyes. Lift breaker out of housing.

9. Turn breaker around 180 degrees.

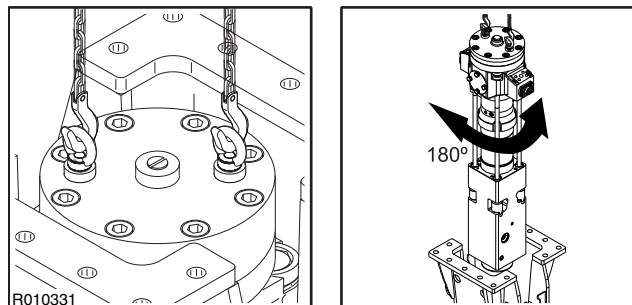

10. Check that wear plates are in correct positions.
11. Lower breaker into housing.
12. Connect grease hose and pressure hose to breaker.
13. Install buffer and mounting bracket.
14. Connect hose couplings to breaker.
15. Install cover.

OPERATION

Movement

The transportation and parking positions are shown below. When moving with the breaker, ensure that it isn't too close and doesn't point at the cabin window.

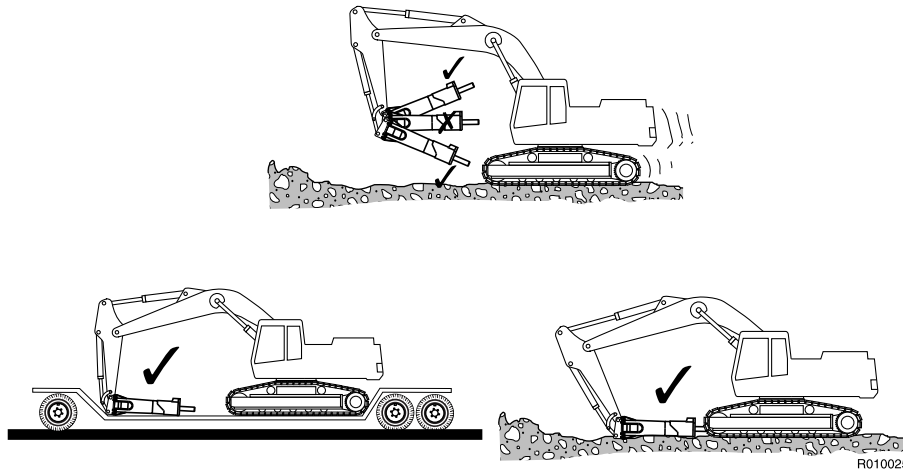

Special conditions of use

Special conditions of use are conditions in which the breaker is used for some work other than normal breaking or demolition, such as:

- Tunneling
- Scaling
- Foundry cleaning
- Underwater operations
- Operations in extremely low or high temperatures
- Use of special hydraulic fluids
- Breaker operations with a special carrier (e.g., an extra long boom)
- Other special conditions

Special conditions of use may require modifications to the attachment, special operating techniques, increased maintenance or special wear items. If you are planning to use the breaker under a special condition of use, please consult your local dealer and/or LaBounty service department for instructions.

OPERATION

Underwater operation



Use environmental friendly oil and tool grease when you are using the breaker under water.



Warning! If you are using the breaker under water, protect yourself and your surroundings against compressed water/air spray and possible broken compressed air hoses.

Warning! If you are using the breaker under water, check the stability of the carrier and the breaker. Water gets inside the breaker, causing it to weigh more. Due to the added water weight, lift the breaker carefully out of the water.

The breaker as a standard assembly, must not be used under water. If water fills the space where the piston strikes the tool, a strong pressure wave is generated and the breaker may be damaged.

The wear resistance of the breaker parts is considerably lower under water than in normal use. This is caused by corrosion and by the abrasive effect of mud in water. After starting underwater breaking, the breaker must be inspected regularly, for example after every half hour operation. Adapt the inspection intervals to the working conditions. See "Maintenance intervals in underwater use" on page 56.

In underwater applications, the productivity of a hydraulic breaker is considerably lower than in normal work. This is caused by:

1. The breaking object is not visible to the operator. This causes misalignment between the tool and the object and unnecessary idle strokes.
2. The breaker must be inspected and greased more often than in normal situations.
3. **The breaker must always be completely serviced after working on underwater job sites.**

OPERATION

Storage

Long term storage

Observe the following points when the breaker is stored. In this way the vital parts of the attachment are protected from rust and the machine is ready to be used whenever necessary.

1. The storage area must be dry.
2. The tool must be removed in hydraulic breakers.
3. The lower end of the piston, tool and tool bushings must be well protected with grease in all hydraulic breakers.
4. Connections must be sealed with clean plugs to prevent oil leakage and dirt from getting into couplings.
5. The product must be stored in the vertical position.
6. Make sure the product cannot fall.

OPERATION

LUBRICATION

BREAKER TOOL GREASING

BREAKER TOOL GREASING

Recommended greases

- No dropping point or very high, over 250 °C (480 °F).
- Maximum service temperature at least 150 °C (300 °F).
- Minimum working temperature below lowest ambient temperature.
- Additives: molybdenum disulfide (MoS₂), graphite or equivalent.
- Penetration 0 ... 2 (NLGI).
- No reaction with hydraulic oils.
- Water resistant.
- Good adhesion with steel.

Automatic greasing

- GREASE CARTRIDGE, part no. 77726



Wear gloves when handling the grease containers. If you get grease onto your skin, wash it away with water.

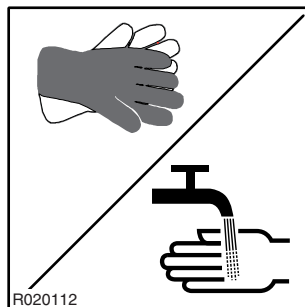

BREAKER TOOL GREASING

Automatic greasing



Dispose of empty grease containers appropriately.

The breaker can be equipped with an automatic greasing device. See “Greasing device” on page 12.

Do not remove the grease cartridge unnecessarily. Always keep the grease cartridge in the greasing device to prevent dirt from entering the greasing device.

Note: Some breaker models are equipped with an adapter kit for manual greasing and do not include an automatic greasing device.

Replacing the grease cartridge

Measure the distance from the top of the grease cartridge. Replace the grease cartridge if the distance is more than 200 mm (7.87 in). The grease cartridge is empty and has to be replaced when the distance is 210 mm (8.27 in).

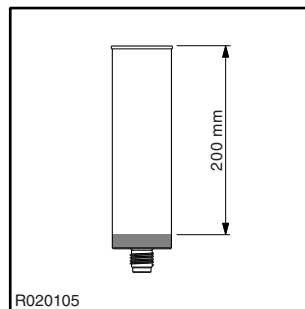

1. Unscrew and remove the grease cartridge.
2. Dispose the used cartridge appropriately. Note: The grease cartridge is disposable; it can not be refilled.
3. Check and clean the grease cartridge seat in the cartridge holder. Remove the old grease cartridge seal.
4. Remove the protective cap from the new cartridge.

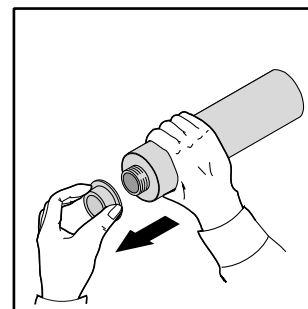
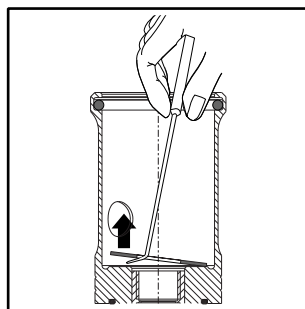
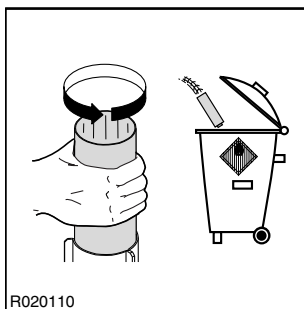

5. Check the grease cartridge seal.

BREAKER TOOL GREASING

6. Push the cartridge piston with fingers until approximately 15 mm of grease comes out.
7. Insert the cartridge and tighten it.

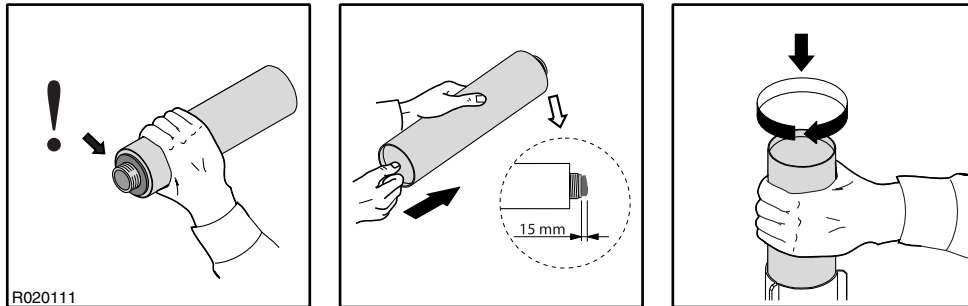

Adjusting the dose

Note: Some breaker models are equipped with an adapter kit for manual greasing and do not include an automatic greasing device.

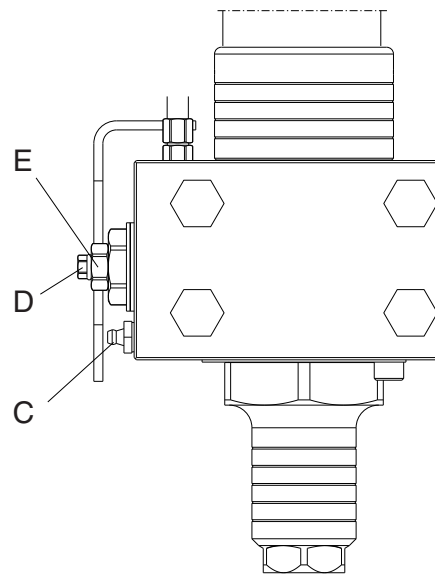
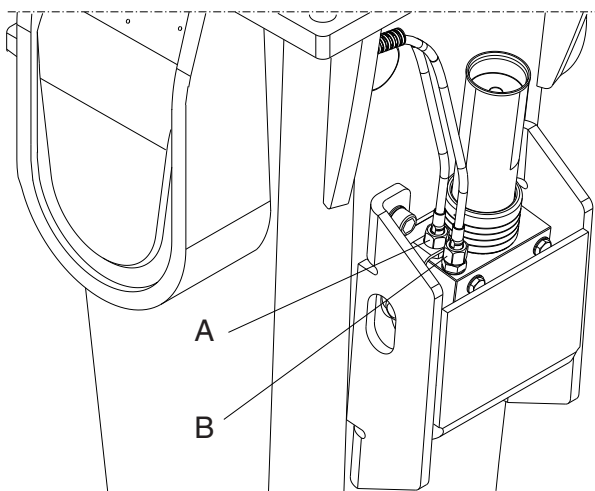

R020125

- A. Grease hose
- B. Pressure hose
- C. Grease zerk for manual greasing
- D. Adjusting screw for grease dosage
- E. Locking nut for the adjusting screw

BREAKER TOOL GREASING

Adjusting the dose

Please note that the actual amount of grease needed for proper lubrication varies according to:

- breaker size
- application: the amount of grease depends on the number of working cycles within a given time. In practice this means that, in an application where the working cycles are short but the quantity is high, a smaller dose can be used.
- wear rate of the tool shank and bushing
- condition of the tool seal
- operators working techniques
- grease quality

1. Turn the locking plate and plug aside.

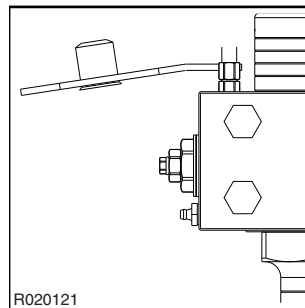

2. Open the locking nut.

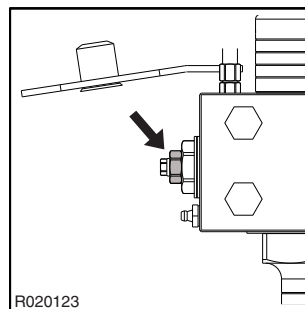

3. Turn the adjusting screw for grease dosage clockwise to close it completely.

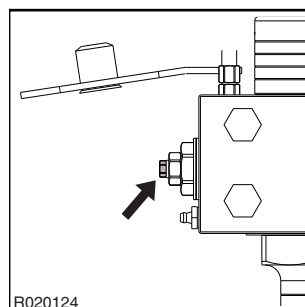

4. Next open the adjusting screw for grease dosage by turning it counter-clockwise as needed. See table below.

BREAKER TOOL GREASING

5. Tighten the locking nut to the specified torque setting. See table below.
6. Turn the locking plate and plug to the correct positions.

Item	Specification/Torque
Shield screws	175 Nm (129 lbf ft)
Adjusting screw locking nut	50 Nm (37 lbf ft)
Adjusting range	Linear 0 ... 7 turns (7 mm)
Basic adjustment	4 turns open / means 0.25 g grease/ impact period
1-turn adjustment	0.053 g grease/impact period

Manual greasing



Follow the product's greasing instructions and avoid excessive greasing. Dispose of empty grease containers appropriately.

Manual greasing is always possible even if the breaker is equipped with the automatic greasing device. Manual greasing is necessary if there is no grease available for the greasing device, greasing device has malfunction or pressure hose is damaged. Check also the grease hose conditions inside the housing.

Greasing interval

1. Tool shank must be well lubricated before installing tool.
2. 5-10 strokes from grease gun to tool bushings and tool at regular intervals.

Insufficient greasing or improper grease may cause:

- Abnormal wear of tool bushing and tool
- Tool breakage

BREAKER TOOL GREASING

Correct greasing

1. Position the breaker standing upright resting on the tool on firm surface.
2. Stop carrier engine and wait 10 minutes for oil pressure to drop inside breaker.
3. Apply tool grease from grease gun to greasing points marked with the following sticker.



R020002

Note: The breaker must stand upright resting on the tool to ensure that the grease will penetrate downwards between the tool and the bushing.

Do not fill the space between the piston and the tool with grease. A lower piston seal failure can result and the breaker will subsequently leak oil.

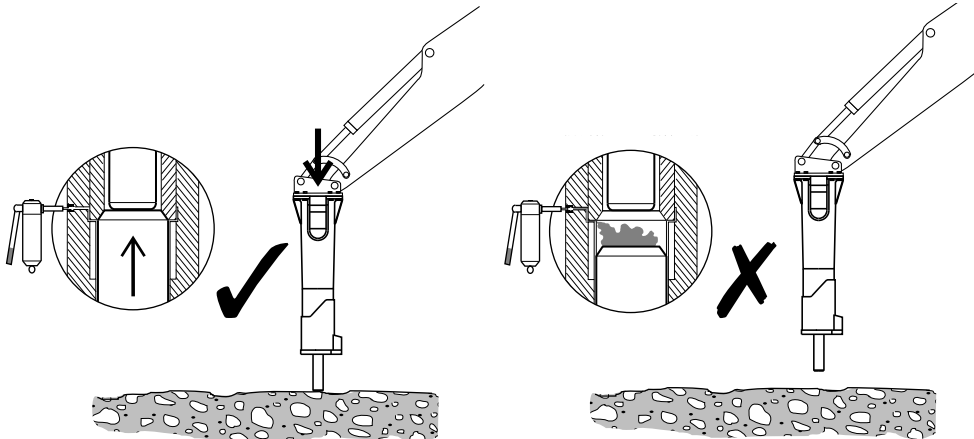

R020001

CARRIER HYDRAULIC OIL

CARRIER HYDRAULIC OIL

Requirements for hydraulic oil

General requirements

In general the hydraulic oil originally intended for the carrier can be used with this product. However, since working with the product heats the oil more than the usual excavation work, the temperature of the oil must be monitored.

If the temperature of the hydraulic oil exceeds 80 °C (176 °F), an auxiliary oil cooler is needed. The oil viscosity must be between 20-1000 cSt while the attachment is being used.

When the product is used continuously, the temperature of the hydraulic oil normalizes at a certain level depending on conditions and on the carrier. The temperature in the tank must not exceed the maximum allowed.

The breaker must not be started if the ambient temperature is below freezing and the oil is very thick. The machine must be moved to bring the oil temperature above 0 °C (32 °F) before breaking can start (viscosity 1000 cSt or 131 °E).

Oil specifications

Table below shows hydraulic oils recommended for breaker use. The most suitable oil is selected in such a way that the temperature of the hydraulic oil in continuous use is in the ideal area on the chart and the hydraulic system is used to best advantage.

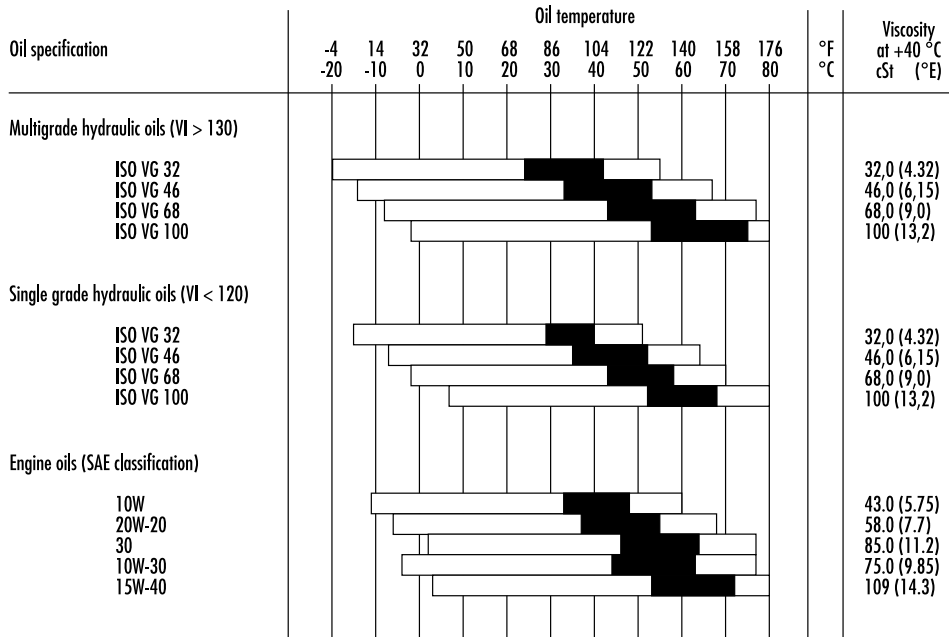

VI = Viscosity index
 □ Permitted oil temperature
 ■ Recommended oil temperature

R020004

CARRIER HYDRAULIC OIL

Problems due to incorrect hydraulic oil viscosity in the breaker:

Oil too thick

- Difficult start up
- Stiff operation
- Breaker strikes slowly
- Danger of cavitation in pumps and in the hydraulic breaker
- Sticky valves
- Filter bypass opens, impurities in the oil are not removed

Oil too thin

- Efficiency losses (internal leaks)
- Damage to gaskets and seals, leaks
- Accelerated wearing of parts, because of decreased lubrication efficiency
- Breaker strikes irregularly and slowly
- Danger of cavitation in pumps and in the hydraulic breaker

Note: We strongly recommend the use of different hydraulic oils in the summer and in the winter if there is an average temperature difference of more than 35 °C (63 °F). The correct hydraulic oil viscosity is thus ensured.

Special oils

In some cases special oils (for example biological oils and non-inflammable oils) can be used with hydraulic breakers. Observe the following aspects when considering the use of special oils:

- The viscosity range in the special oil must be in the given range (20-1000 cSt)
- The lubrication properties must be sufficient
- The corrosion resistance properties must be good enough

Note: Although a special oil could be used in the carrier, always check its suitability with the breaker due to high piston speed of the breaker. Contact the oil manufacturer or your local dealer for more information about special oils.

CARRIER HYDRAULIC OIL

Oil cooler

The correct place to connect the breaker return line is between the oil cooler and the main filters. The breaker return line should not be connected before the oil cooler. Routing the breaker return flow through the cooler, might damage either the cooler, due to pulsating flow, or the breaker, due to increased back pressure.

The carrier hydraulic system must be able to maintain the temperature within an acceptable level during the breaker operation. This is for two reasons.

1. Seals, wipers, membranes and other parts manufactured from the corresponding materials can normally stand temperatures up to 80 °C (176 °F).
2. The higher the temperature is, the less viscous the oil gets thus losing its capability to lubricate.

A standard carrier, with a proper breaker circuit, meets the requirements of the necessary cooling capacity. If the oil temperature tends to be too high during the breaker operation, the following things must be checked:

- The breaker circuit pressure relief valve is not open when the breaker is operated.
- The breaker circuit pressure drops are reasonable. Less than 10 bar (145 psi) in the pressure line and less than 5 bar (75 psi) in the return line.
- Hydraulic pumps, valves, cylinders, motors etc. and breaker do not have internal leakages.

If all of the above mentioned things are in order, and the temperature of the hydraulic oil still tends to be too high, extra cooling capacity is needed. Consult the carrier manufacturer or dealer for details.

Oil filter

The purpose of the oil filter is to remove impurities from the hydraulic oil. Air and water are also impurities in oil. Not all impurities can be seen with the naked eye.

Impurities enter the hydraulic system:

- During hydraulic oil changes and refilling.
- When components are repaired or serviced.
- When the breaker is being installed on the carrier.
- Because of component wear.

Normally the existing main oil filters of the carrier are used as breaker circuit return line filters. Consult the carrier manufacturer or your local dealer concerning instructions for the filter change intervals.

CARRIER HYDRAULIC OIL

In hydraulic breaker work the carrier oil filter must fulfil the following specifications:

- The oil filter must allow maximum particle size of 25 microns (0.025 mm).
- The oil filter material must be artificial fibre cloth or very fine gauge metallic mesh to withstand pressure fluctuations.
- The oil filter must have a nominal flow capacity of at least twice the breaker's maximum flow.

In general, oil companies guarantee new oils to have a particle count of 40 microns maximum. Filter the oil when filling the tank.

The damage caused by hydraulic oil impurities in the carrier and breaker circuits:

1. The working life of the pumps and other components is significantly shortened.

- Rapid wear of parts.
 - Cavitation.
2. Wear of cylinder and gaskets.
3. Reduced breaker efficiency.
- Accelerated wear of moving parts and seals.

- Danger of piston seizing up.

- Oil leakages.

4. Shortened working life and reduced lubricating capability of oil.

- Oil overheats.
- Oil quality deteriorates.
- Electro-chemical changes in hydraulic oil.

5. Valves do not function properly.

- Spools bind.
- Rapid wear of parts.
- Blocking of small holes.

Note: Component damage is only a symptom. The trouble itself will not be cured by removing the symptom. After any component damage due to impurities in the oil, the entire hydraulic system has to be cleaned. Dismantle, clean and reassemble the breaker and change the hydraulic oil.

CARRIER HYDRAULIC OIL

MAINTENANCE

ROUTINE MAINTENANCE

ROUTINE MAINTENANCE

Overview

This product is a precision made hydraulic machine. Therefore great care and cleanliness should be taken when handling any of the hydraulic components. Dirt is the worst enemy in hydraulic systems.

Handle the parts carefully and remember to cover any cleaned and dried parts with clean lint-free cloth. Do not use anything other than purpose designed materials for cleaning hydraulic parts. Never use water, paint thinners or carbon tetrachloride.

Components, gaskets and seals in the hydraulic system should be oiled with clean hydraulic oil before assembly.

Inspection and maintenance by the operator

Note: The time intervals given refer to the carrier hours while the attachment is installed.

Every two hours

- Check that the grease cartridge is not empty. Replace if necessary.
- Check that the tool has received sufficient grease.
- Grease manually if the automatic greasing device is not in use. See "Manual greasing" on page 46.
- Observe hydraulic oil temperature, all lines and connections as well as impact efficiency and evenness of operation.
- Tighten loose connections.

Every 10 hours or at least once a week

- Remove the tool retaining pin and the tool and check their condition. Grind the burrs away if necessary. See "Changing the tool" on page 57.
- Check that the tool has received sufficient greasing. Grease more frequently, if necessary.

ROUTINE MAINTENANCE

Every 50 hours or at least once a month

- Check the tool shank and tool bushings for wear. See “Changing the tool” on page 57. See “Lower tool bushing” on page 60.
- Check the hydraulic hoses. Replace if necessary. Do not let dirt get into the breaker or hoses.
- Check that the breaker moves normally inside the housing and that vibration dampening elements (pads and buffers) are in good condition.
- Check the condition of wear plates by moving breaker with a pry bar from side to side inside housing. The maximum allowed clearance is approximately ± 10 mm.

Inspection and maintenance by the dealer

Note: The times given refer to the carrier hours while the attachment is installed.

Initial 50-hour inspection

It is recommended to have the first inspection done by your local dealer after 50 to 100 operating hours. Contact your local dealer for more information about the initial 50-hour inspection.

Every 1000 hours or once a year

This service is recommended to be done by your local dealer after 1000 operating hours or at least once a year. Neglecting the annual service can cause severe damage to the breaker.

Your local dealer will reseal the breaker, replace the accumulator membranes and replace safety decals as needed. Contact your local dealer for more information about annual servicing.

During this maintenance you should do the following tasks.

- Check all hydraulic connections.
- Check that the hydraulic hoses do not rub against anything in any boom position.
- Inspect the hydraulic oil filters of the carrier and replace if needed.

Maintenance intervals in special applications

The service interval is considerably shorter in special applications. See “Special conditions of use” on page 37. In special applications, please consult your local dealer and/or LaBounty service department and/or LaBounty service department and/or LaBounty service department for the correct service intervals.

ROUTINE MAINTENANCE

Maintenance intervals in underwater use

After every half hour operation

- Grease the tool shank and the tool bushings through the grease zerks.
- Check that the breaker moves normally inside the housing and that the buffers are in good condition.
- Check all hoses and connections.
- Check the operation of the air pressure switch.

Daily maintenance

- Remove the retaining pin and the tool for inspection. Grind the burrs away if necessary.
- Check that the tool has received sufficient grease.
- Service the hammer after underwater jobs.

The breaker must be totally dismantled and serviced after working underwater.

Neglecting a breaker service after underwater work can cause severe damage to the breaker.



The breaker as a standard assembly, must not be used under water. If water fills the space where the piston strikes the tool, a strong pressure wave is generated and the breaker may be damaged.

Other maintenance procedures

Washing the attachment

When working with attachment and removing it from the carrier, dirt (mud, rock powder etc.) can become attached to it. Wash the outside of the product with a steam washer before sending it to the workshop. Dirt can cause difficulties in disassembly and assembly otherwise.

CAUTION! Plug the pressure and return line and other connections before washing the product or else dirt can enter into it and this may cause damage to the components.

CHANGING THE TOOL

CHANGING THE TOOL

Wear limits and lubricants for tool removal

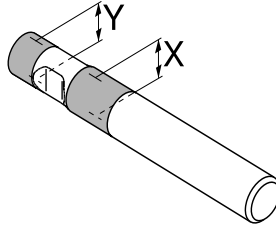

R030045

Item	Wear limit
Tool diameter X (worn out)	113 mm (4.45 in)
Tool diameter Y (worn out)	104 mm (4.09 in)

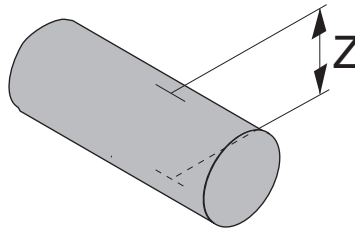

R030149

Item	Wear limit
Tool retaining pin diameter Z (worn out)	52 mm (2.05 in)

Item	Lubricant
Tool and tool retaining pins	Tool grease

CHANGING THE TOOL

Removal of tool



Warning! The hydraulic pressure inside the breaker must always be released before removing the tool. After operating the breaker, wait 10 minutes for oil pressure to drop inside breaker.

Warning! Hot tool can cause severe injuries.

1. Set the breaker on level ground.
2. Make sure the carrier's transmission is in neutral and the parking brake is engaged.
3. Stop the carrier engine.
4. Remove plug.
5. Remove rubber ring.
6. Remove tool retaining pin by using t-puller.

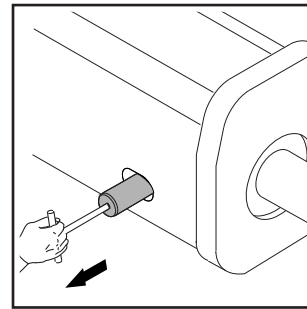
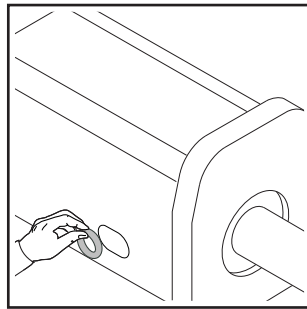
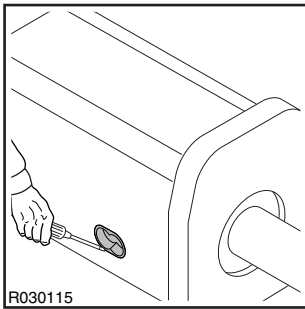

7. Remove tool. Use lifting device if necessary.

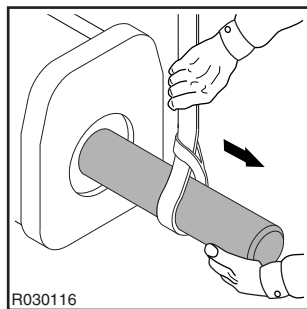

Note: If breaker is still on carrier, it may be easier to stick the tool in the ground and lift the breaker off the tool. Make sure that the tool cannot fall.

CHANGING THE TOOL

Installation of tool

1. Clean all parts carefully.
2. Measure the tool diameters (X and Y) from the areas marked on the illustration. Replace tool if necessary. See “Changing the tool” on page 57.
3. Measure the tool retaining pin diameter (Z). Replace tool if necessary. See “Changing the tool” on page 57.
4. Check tool seal. Replace if necessary.

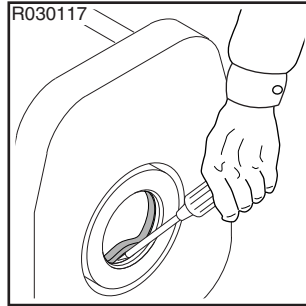

5. Clean the tool and retaining pin and lubricate them with grease.
6. Install tool and align the groove of the tool with the pin bores.
7. Install tool retaining pin.
8. Install rubber ring.
9. Install plug.

LOWER TOOL BUSHING

LOWER TOOL BUSHING

Wear limits and lubricants for lower tool bushing

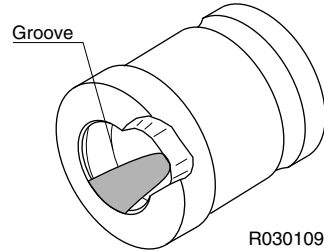

Item	Wear limit
Tool bushing (worn out)	Grease groove is worn out. Bushing must be replaced.

Item	Lubricant
Contact surfaces of front head	Thread grease

Removal of lower tool bushing

The lower tool bushing can not be removed without removing the breaker from the housing. Contact your local dealer for more information.

TROUBLESHOOTING

TROUBLESHOOTING

The breaker does not start

PRESSURE OR RETURN LINES CLOSED

Check the operation of quick couplings in breaker line. Open breaker line ball valves if closed.

PRESSURE AND RETURN HOSES INSTALLED BACKWARDS

Swap the pressure and return hoses.

PISTON IS IN ITS LOWER HYDRAULIC BRAKE

Keep the breaker control valve open and force the tool against an object. The tool head will push the piston out of its brake area. See “Daily operation” on page 27.

GREASE BETWEEN PISTON AND TOOL CONTACT AREA

Remove the tool and wipe excessive grease off. See “Manual greasing” on page 46.

BREAKER CONTROL VALVE DOES NOT OPEN

When operating the breaker control valve, check that the pressure line pulsates (this indicates the breaker control valve is opening). If the valve does not operate, check the operating means: mechanical connections, pilot pressure or electrical control.

RELIEF VALVE IN HYDRAULIC CIRCUIT OPENS AT A LOW PRESSURE. BREAKER OPERATING PRESSURE IS NOT REACHED

Check the installation. Check the relief valve operation. Adjust the relief valve in hydraulic circuit. Measure the high pressure in the breaker inlet line.

EXCESSIVE BACK PRESSURE IN RETURN LINE

Check the installation. Check the size of the return line.

LEAKAGE FROM PRESSURE TO RETURN IN EXCAVATOR HYDRAULIC CIRCUIT

Check the installation. Check the pump and the other hydraulic components.

FAILURE IN BREAKER VALVE OPERATION

The breaker must be serviced in an authorized Stanley service shop.

PISTON FAILURE

The breaker must be serviced in an authorized Stanley service shop.

TROUBLESHOOTING

The breaker operates irregularly but the blow has full power

NOT ENOUGH FEED FORCE FROM EXCAVATOR

Refer to the correct working methods. See “Daily operation” on page 27.

RELIEF VALVE IN HYDRAULIC CIRCUIT OPENS AT A LOW PRESSURE. BREAKER OPERATING PRESSURE IS NOT REACHED

Check the installation. Check the relief valve operation. Adjust the relief valve in hydraulic circuit. Measure the high pressure in the breaker inlet line.

FAILURE IN BREAKER VALVE OPERATION

The breaker must be serviced in an authorized Stanley service shop.

The breaker operates irregularly and blow has no power

THE WORKING METHOD IS NOT CORRECT

Refer to the correct working methods. See “Daily operation” on page 27.

RELIEF VALVE IN HYDRAULIC CIRCUIT OPENS AT A LOW PRESSURE. BREAKER OPERATING PRESSURE IS NOT REACHED

Check the installation. Check the relief valve operation. Adjust the relief valve in hydraulic circuit. Measure the high pressure in the breaker inlet line. Contact your local dealer for more information.

PRESSURE CONTROL VALVE SETTING IS INCORRECT

The breaker must be serviced in an authorized Stanley service shop.

PRESSURE LOSS IN PRESSURE ACCUMULATOR

The breaker must be serviced in an authorized Stanley service shop.

FAILURE IN BREAKER VALVE OPERATION

The breaker must be serviced in an authorized Stanley service shop.

TROUBLESHOOTING

Impact rate slows down

OIL HAS OVERHEATED (OVER +80 °C/+176 °F)

Check for a fault in the oil cooling system or an internal leak in the breaker. Check the hydraulic circuit of the carrier. Check the relief valve operation in the carrier. Check the line size. Assemble an extra oil cooler.

HYDRAULIC OIL VISCOSITY TOO LOW

Check hydraulic oil. See “Requirements for hydraulic oil” on page 48.

EXCESSIVE BACK PRESSURE IN RETURN LINE

Check the installation. Check the size of the return line.

RELIEF VALVE IN HYDRAULIC CIRCUIT OPENS AT A LOW PRESSURE. BREAKER OPERATING PRESSURE IS NOT REACHED

Check the installation. Check the relief valve operation. Adjust the relief valve in hydraulic circuit. Measure the high pressure in the breaker inlet line. Contact your local dealer for more information.

LEAKAGE FROM PRESSURE TO RETURN IN EXCAVATOR HYDRAULIC CIRCUIT

Check the installation. Check the pump and the other hydraulic components.

OIL FLOW FROM THE CARRIER IS TOO HIGH

The hammer is equipped with a built-in restrictor valve which is designed to decrease oil flow to the breaker when oil flow from the carrier is too high. If impact rate is too slow check the oil flow. Contact your local carrier dealer for more information.

PRESSURE LOSS IN PRESSURE ACCUMULATOR

The breaker must be serviced in an authorized Stanley service shop.

FAILURE IN BREAKER VALVE OPERATION

The breaker must be serviced in an authorized Stanley service shop.

The breaker does not stop or has run-on

INTERNAL OIL LEAK IN THE BREAKER

The breaker must be serviced in an authorized Stanley service shop.

FAILURE IN BREAKER CONTROL VALVE OPERATION

Check the breaker control valve in the carrier.

TROUBLESHOOTING

Oil overheats

APPLICATION NOT CORRECT FOR BREAKER

Refer to recommended use and to correct working methods. See “Daily operation” on page 27.

COOLING CAPACITY OF THE FACTORY OIL COOLER IS TOO SMALL

Assemble an extra oil cooler.

RELIEF VALVE IN HYDRAULIC CIRCUIT OPENS AT A LOW PRESSURE. BREAKER OPERATING PRESSURE IS NOT REACHED

Check the installation. Check the relief valve operation. Adjust the relief valve in hydraulic circuit. Measure the high pressure in the breaker inlet line. Contact your local dealer for more information.

HYDRAULIC OIL VISCOSITY TOO LOW

Check hydraulic oil. See “Requirements for hydraulic oil” on page 48.

LEAKAGE FROM PRESSURE TO RETURN IN EXCAVATOR HYDRAULIC CIRCUIT

Check the installation. Check the pump and the other hydraulic components.

INTERNAL OIL LEAK IN THE BREAKER

The breaker must be serviced in an authorized Stanley service shop.

EXCESSIVE BACK PRESSURE IN RETURN LINE

Check the installation. Check the size of the return line.

Recurrent tool failure

APPLICATION NOT CORRECT FOR BREAKER

Refer to recommended use and to correct working methods. See “Operating instructions” on page 24.

ROUGH OPERATING PRACTICES

Refer to recommended use and to correct working methods. See “Daily operation” on page 27.

TOOL DOES NOT GET ENOUGH LUBRICANT

Refer to recommended use and to correct working methods.

RAPID WEAR OF TOOL

Refer to recommended use and to correct working methods. See “Daily operation” on page 27. There is a wider selection of tools available for different applications. Consult with your local dealer for more information.

TROUBLESHOOTING

Automatic greasing device problems

UPPER OR LOWER TOOL BUSHING DOES NOT GET ENOUGH LUBRICANT

- Cold conditions. Apply grease from grease gun to grease zerks.
- Doser adjusting is wrong for the application. The doser must be readjusted. See “Adjusting the dose” on page 44.
- Blockage in greasing device. Contact your local dealer for more information.

UPPER OR LOWER TOOL BUSHING GETS TOO MUCH LUBRICANT

- Doser adjusting is wrong for the application. The doser must be readjusted. See “Adjusting the dose” on page 44.
- Leak in the doser. The doser must be replaced. Contact your local dealer for more information.

TOOL DOES NOT GET LUBRICANT AT ALL

- Grease cartridge is empty or damaged. Replace the grease cartridge. See “Automatic greasing” on page 43.
- Grease cartridge is empty or damaged. Replace the grease cartridge.
- Doser defective. The doser must be replaced. Contact your local dealer for more information.
- Leak in the grease hose or pressure hose. Inspect the hoses and replace if necessary.
- Grease and pressure hoses are installed backwards. Swap the hoses.
- To continue troubleshooting, disconnect the grease hose from the breaker valve body and operate the breaker. After 10 minutes of operation check if grease has protruded from the grease hose.

LUBRICATION DEVICE IS WORKING (WHILE THE GREASE HOSE IS DISCONNECTED)

- Leak in breaker lubrication channel. The breaker must be serviced in an authorized Stanley service shop.
- Breaker lubrication channel is blocked. The breaker must be serviced in an authorized Stanley service shop.

LUBRICATION DEVICE DOES NOT WORK (WHILE THE GREASE HOSE IS DISCONNECTED)

- Remove the lubrication device from the breaker and deliver it for service in an authorized Stanley service shop.

TROUBLESHOOTING

Further assistance

FURTHER ASSISTANCE

If further assistance is required, please prepare to answer the following questions before calling your dealer.

- Model and serial number
- Working hours and service history
- SDC report if available
- Carrier model
- Installation: Oil flow, operating pressure and return line pressure if known
- Application
- Has the product operated normally before

SPECIFICATIONS

BREAKER SPECIFICATIONS

BREAKER SPECIFICATIONS

Technical specifications

Item	Specification
Minimum working weight ¹	1090 kg (2400 lb)
Breaker weight	870 kg (1920 lb)
Impact rate ²	540...920 bpm
Operating pressure ³	135...145 bar (1960...2105 psi)
Pressure relief, min ⁴	190 bar (2755 psi)
Pressure relief, max	220 bar (3190 psi)
Oil flow range	90...130 l/min (23.8...34.3 gal/min)
Back pressure, max	10 bar (145 psi)
Input power	31 kW (42 hp)
Tool diameter	115 mm (4.53 in)
Pressure line connection (IN)	SAE 6000 psi 1"
Return line connection (OUT)	SAE 6000 psi 1"
Grease connection (G) ⁵	BSPP-internal 3/8"
Air connection (A) ⁶	BSPP-internal 3/8"
Pressure line size (minimum inner diameter)	26 mm (1.02 in)
Return line size (minimum inner diameter)	26 mm (1.02 in)
Optimum oil temperature	40...60 °C (104...140 °F)
Allowed oil temperature range	-20...80 °C (-4...176 °F)
Optimum oil viscosity at operating temperature	30...60 cSt
Allowed oil viscosity range	20...1000 cSt
Carrier weight ⁷	12...20 t (26500...44100 lb)
Noise level, measured sound power level, LWA ⁸	123 dB (123 dB)
Noise level, guaranteed sound power level, LWA ⁹	127 dB (127 dB)

1. Includes average mounting bracket and standard tool
2. Actual impact frequency depends on oil flow, oil viscosity, temperature, and material to be broken
3. Actual pressure depends on oil flow, oil viscosity, temperature, material to be broken and back pressure
4. Minimum setting = actual operating pressure + 50 bar (730 psi)
5. Located on the same side of the valve body as the return line (OUT) connection
6. Located on the same side of the valve body as the pressure line (IN) connection
7. Check carrier's lifting capacity from carrier manufacturer
8. According to European Union DIRECTIVE 2000/14/EC
9. According to European Union DIRECTIVE 2000/14/EC

BREAKER SPECIFICATIONS

Main dimensions

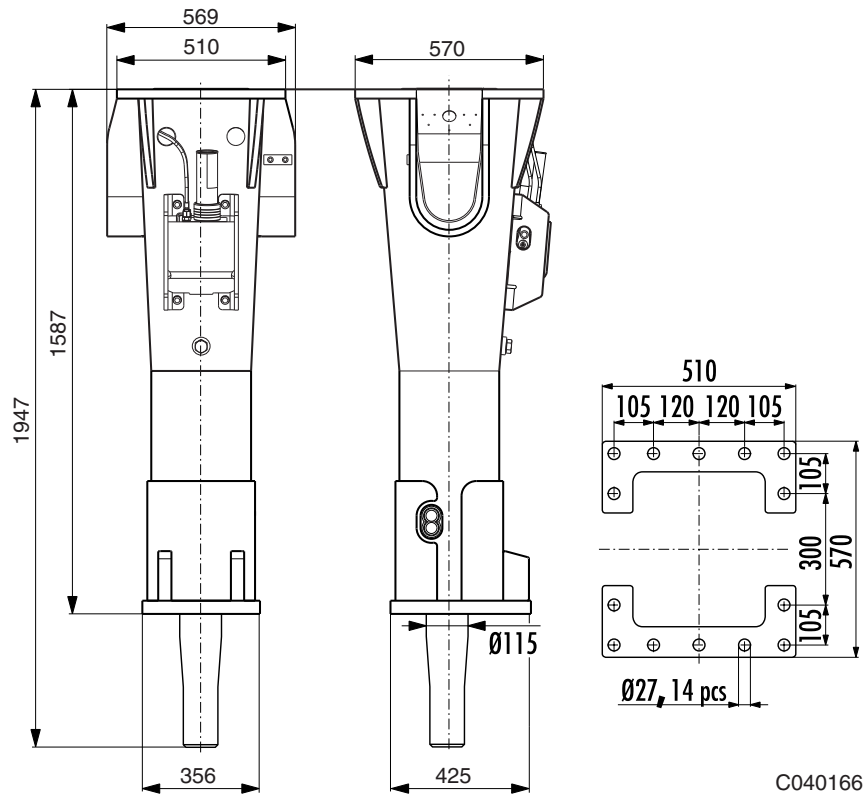

Mounting bracket specifications

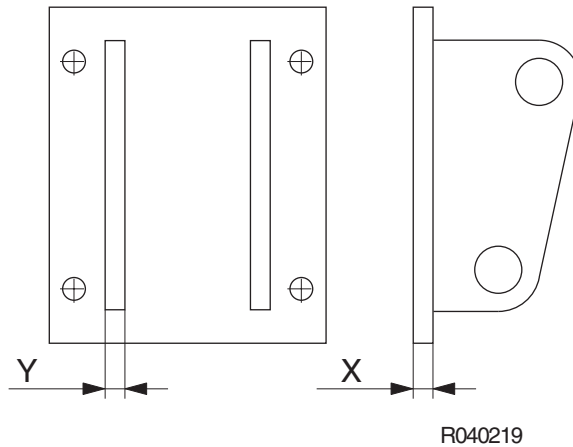

Item	Specification
After welding check flatness of the plate and mill surface as needed. Maximum acceptable deviation from flatness is 1 mm (0.04 in)	
Bottom plate recommended minimum thickness (X)	25 mm (0.98 in)
Side plate recommended minimum thickness (Y)	25 mm (0.98 in)

STANLEY

Stanley, 1538 Highway 2,
Two Harbors, MN 55616 USA

90-44-14119-24-44-315
90-44-14119-24-232-21