STANLEY

HS3000 MOUNTED HYDRAULIC COMPACTOR



SAFETY, OPERATION AND MAINTENANCE USER'S MANUAL



CE

© 2011 Stanley Black & Decker, Inc.
New Britain, CT 06053
U.S.A.
65763 10/2012 Ver. 5

TABLE OF CONTENTS

CERTIFICATE OF CONFORMITY	4
SAFETY SYMBOLS	5
SAFETY PRECAUTIONS.....	6
TOOL STICKERS & TAGS	7
OPERATION.....	8
PREOPERATION PROCEDURES	8
DAILY MAINTENANCE CHECKS	8
PRE-INSTALLATION INSTRUCTIONS	8
LOW-TEMPERATURE WARM-UP PROCEDURE	8
GENERAL INSTRUCTIONS.....	9
COMPACTION.....	9
GENERAL.....	9
SLOPE TECHNIQUE.....	9
SOIL TESTING	9
DRIVING.....	9
TROUBLESHOOTING	11
FLOW TEST PROCEDURES.....	12
DEFINITION OF TERMS.....	14
SPECIFICATIONS.....	15
HS3000 PARTS ILLUSTRATION	17
HS3000 PARTS LIST	18

IMPORTANT

To fill out a Product Warranty Recording form, and for information on your warranty, visit Stanleyhydraulic.com and select the Warranty tab.
(NOTE: The warranty recording form must be submitted to validate the warranty).

SERVICING THE STANLEY HYDRAULIC compactor. This manual contains safety, operation, and routine maintenance instructions. Servicing of hydraulic tools, other than routine maintenance, must be performed by an authorized and certified dealer. Please read the following warning.

⚠ WARNING

SERIOUS INJURY OR DEATH COULD RESULT FROM THE IMPROPER REPAIR OR SERVICE OF THIS TOOL.

REPAIRS AND / OR SERVICE TO THIS TOOL MUST ONLY BE DONE BY AN AUTHORIZED AND CERTIFIED DEALER.

For the nearest authorized and certified dealer, call Stanley Hydraulic Tools at the number listed on the cover of this manual and ask for a Customer Service Representative.

DECLARATION OF CONFORMITY

DECLARATION OF CONFORMITY
ÜBEREINSTIMMUNGS-ERKLÄRUNG
DECLARATION DE CONFORMITE CEE
DECLARACION DE CONFORMIDAD
DICHIARAZIONE DI CONFORMITA



I, the undersigned:
Ich, der Unterzeichnende:
Je soussigné:
El abajo firmante:
Io sottoscritto:

Weisbeck, Andy

Surname and First names/Familiennamen und Vornamen/Nom et prénom/Nombre y apellido/Cognome e nome

hereby declare that the equipment specified hereunder:
bestätige hiermit, daß erklaren Produkt genannten Werk oder Gerät:
déclare que l'équipement visé ci-dessous:
Por la presente declaro que el equipo se especifica a continuación:
Dichiaro che le apparecchiature specificate di seguito:

1. Category: **Hydraulic Powered Compaction Machine**

Kategorie:
Catégorie:
Categoria:
Categoria:

2. Make/Marke/Marque/Marca/Marca

Stanley

3. Type/Typ/Type/Tipo/Tipo:

HS3000, HS6000, HS8000, HS11000, HS22000

4. Serial number of equipment:

Seriennummer des Geräts:
Numéro de série de l'équipement:
Numero de serie del equipo:
Matricola dell'attrezzatura:

All

5. Mass/Masse/Masse/Masa/Massa 168/998 kg

Has been manufactured in conformity with
Wurde hergestellt in Übereinstimmung mit
Est fabriqué conformément
Ha sido fabricado de acuerdo con
E' stata costruita in conformità con

Directive/Standards Richtlinie/Standards Directives/Normes Directriz/Los Normas Direttiva/Norme	No. Nr Numéro No n.	Approved body Prüfung durch Organisme agréé Aprobado Collaudato
EN ISO EN ISO Machinery Directive	12100-1:2009 12100-2:2009 2006/42/EC:2006	Self

6. Special Provisions: **None**
Spezielle Bestimmungen:
Dispositions particulières:
Provisiones especiales:
Disposizioni speciali:

8. Representative in the Union: **Patrick Vervier, Stanley Dubuis 17-19, rue Jules Berthonneau-BP 3406 41034 Blois Cedex, France.**
Vertreter in der Union/Représentant dans l'union/Representante en la Union/Rappresentante presso l'Unione

Done at/Ort/Fait à/Dado en/Fatto a Stanley Hydraulic Tools, Milwaukie, Oregon USA Date/Datum/le/Fecha/Data 1-6-11

Signature/Unterschrift/Signature/Firma/Firma

Andy Weisbeck

Position/Position/Fonction/Cargo/Posizione Engineering Manager

SAFETY SYMBOLS

Safety symbols and signal words, as shown below, are used to emphasize all operator, maintenance and repair actions which, if not strictly followed, could result in a life-threatening situation, bodily injury or damage to equipment.



 **DANGER**

This is the safety alert symbol. It is used to alert you to potential personal injury hazards. Obey all safety messages that follow this symbol to avoid possible injury or death.

 **WARNING**

This safety alert and signal word indicate an imminently hazardous situation which, if not avoided, will result in death or serious injury.

 **CAUTION**

This safety alert and signal word indicate a potentially hazardous situation which, if not avoided, could result in death or serious injury.

CAUTION

This safety alert and signal word indicate a potentially hazardous situation which, if not avoided, could result in death or serious injury.

NOTICE

This signal word indicates a potentially hazardous situation which, if not avoided, may result in property damage.

IMPORTANT

This signal word indicates a situation which, if not avoided, will result in damage to the equipment.

This signal word indicates a situation which, if not avoided, may result in damage to the equipment.

Always observe safety symbols. They are included for your safety and for the protection of the tool.

LOCAL SAFETY REGULATIONS

Enter any local safety regulations here. Keep these instructions in an area accessible to the operator and maintenance personnel.

SAFETY PRECAUTIONS



Tool operators and maintenance personnel must always comply with the safety precautions given in this manual and on the stickers and tags attached to the tool and hose.

These safety precautions are given for your safety. Review them carefully before operating the tool and before performing general maintenance or repairs.

Supervising personnel should develop additional precautions relating to the specific work area and local safety regulations. If so, place the added precautions in the space provided in this manual.

The HS3003/3004 Mounted Hydraulic Compactor's will provide safe and dependable service if operated in accordance with the instructions given in this manual. Read and understand this manual and any stickers and tags attached to the tool and hoses before operation. Failure to do so could result in personal injury or equipment damage.

Check the rule and regulations at your location. The rules might include an employer's work safety program. Regulations may identify hazards such as working around utility supply lines or hazardous slopes.

BE THOROUGHLY TRAINED BEFORE OPERATING THE UNIT ALONE

- Operator training must start in an area without bystanders and use all the controls until he/she can control the machine fully under the conditions of the work area.
- When learning to operate a machine, do so at a slow pace.

KNOW THE WORK CONDITIONS

- The operator must know any prohibited uses or work areas for the machine. For example, excessive slopes and poor or dangerous terrain conditions must be avoided.

OBEY SAFETY RULES

- Replace all faulty or leaking hydraulic hoses or fittings before further operation.
- Always operate the compactor with backhoe outriggers firmly on the surface. The compactor weighs more than the bucket. Position the compactor with caution.
- Travel with the compactor in full tuck (transport) position only.
- Never operate with any person near the compactor or between the compactor and operator.
- Operate the compactor in properly shored trenches and excavations. Do not allow personnel to work in the excavation near compactor operation.
- Make sure all controls (levers and pedals) are in the NEUTRAL position before starting the carrier.
- Wear safety eye protection, hard hat, and safety foot protection while operating the compactor.
- Operate the carrier or compactor from the operator's seat ONLY. Make sure the seat belt is securely fastened before activating any controls.
- Make certain that no other personnel are within the arc prescribed by the movement of the stabilizers, front bucket or backhoe boom.
- Keep hands and feet on the controls at all times when the machine is running.
- Before leaving the operator's seat, always lower the loader arms and the backhoe boom.
- NEVER leave the machine with the engine running. ALWAYS ENGAGE THE PARKING BRAKE.
- Stop the engine before attempting to make any repairs or adjustments to either the carrier or compactor.
- To avoid personal injury or equipment damage, all tool repair, maintenance and service must only be performed by authorized and properly trained personnel.

TOOL STICKERS & TAGS



HS3004

18968
Model Decal



47352
Lift Point Decal

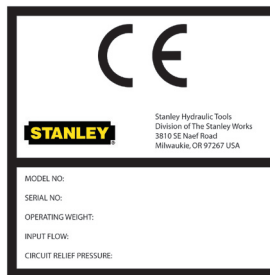

58887
CE Spec Plate



05152
Stanley Decal



47351
Composit Warning

OPERATION

PREOPERATION PROCEDURES

DAILY MAINTENANCE CHECKS

Check for loose or missing fasteners. Tighten or replace as needed. See Torque Specifications in the ASSEMBLY section of this manual.

Check to be certain that the flow control valve on the carrier is set to the proper flow for the compactor. See the SPECIFICATIONS section of this manual.

Check shock mounts for cracks or tears. Rotate shock mounts 180° when fatigue tears begin to show at top outer crease of the shock mount. This will prolong the life of the shock mount.

Check for abrasion and hydraulic leaks at fittings and hoses. Replace defective hoses and fittings. Adjust hoses and tighten fittings so the hoses do not deflect into contact with structure during use.



WARNING

DO NOT USE BARE HANDS TO CHECK OR SEARCH FOR HYDRAULIC LEAKS AROUND HOSES AND FITTINGS. PINHOLE LEAKS CAN PENETRATE THE SKIN. TO INSPECT FOR LEAKS, DEPRESSURIZE THE SYSTEM, CLEAN AROUND SUSPECTED AREA, REPRESSURIZE THE SYSTEM, AND VISUALLY CHECK FOR LEAKS.

Lubricate bearings with two pumps of grease every 40 hours of operation. A greasing location is provided in both bearing carriers.

Inspect pins and bushings for correct fit and lubrication.

Check level of hydraulic reservoir on carrier.

Make certain that quick couplers are fully engaged and leak free.

PRE-INSTALLATION INSTRUCTIONS

Test the carrier hydraulic system to verify that the system is operating at the manufacturer's specified capacity and pressure ratings.

Be sure the fluid and filter in the hydraulic system are clean.

When tightening pipe threads, be careful that any sealant used (Teflon® tape, etc.) *does not* enter the hydraulic system. Foreign matter introduced into the system may damage hydraulic valves, motors and pumps.

Follow instructions to install the Stanley priority valve in the carrier hydraulic system. The warranty is in effect only if the valve and compactor are installed as outlined in the valve kit installation instructions. Major modifications or equipment substitution will cause the warranty to be void unless prior engineering approval has been granted by Stanley Hydraulic Tools.

The Stanley priority valve is a metering (to the hydraulic tool) pressure compensating valve that controls the flow to the attachment and gives the primary system (i.e. backhoe functions) full operating pressure. Diverter valves or simple flow control valves will not perform all of these required functions.

Note:

On carriers where priority valves are not used, check with your local Stanley distributor for an adapter kit to equip your carrier for a specific model of compactor.

LOW-TEMPERATURE WARM-UP PROCEDURE

When the weather gets cold, the shock mounts on compactors can become stiff. In severe weather, where the ambient temperature is below freezing for extended periods, shock mounts can even become brittle. Therefore, it is necessary to warm the shock mounts prior to using the compactor. To warm the shock mounts follow these steps:

1. After starting the carrier, warm up the system until hydraulic lines are warm to the touch.
2. With the carrier at idle, place the compactor flat on the ground, and using a slight down pressure to keep the compactor in place, turn the compactor on. **DO NOT** place a load on the compactor during this procedure.
3. When the ambient temperature is below freezing, the compactor should be operated on the ground with a slight down pressure (no load) *for at least one minute* before putting it to work.

OPERATION

IMPORTANT

DO NOT SUSPEND THE COMPACTOR IN THE AIR DURING THE WARM-UP PROCEDURE.

THE COMPACTOR MUST BE PLACED FLAT ON THE GROUND WITH A VERY SLIGHT DOWN PRESSURE TO KEEP IT IN PLACE. WHEN AMBI-ENT TEMPERATURES ARE BELOW FREEZING, SUSPENDING THE COMPACTOR IN THE AIR WITHOUT FIRST WARMING IT UP MAY CAUSE THE SHOCK MOUNTS TO CRACK.

FAILURE TO FOLLOW THESE PROCEDURES WILL VOID COMPACTOR SHOCK MOUNT WAR-RANTY.

With a standard baseplate, the compactor is held with full down pressure for no more than 5-10 seconds. The application pattern should always begin next to a bank or footing and at the previously compacted area. When the maximum attainable density for that particular soil condition is reached, a slight increase in vibration will be felt by the operator. This increase in vibration is in no way harmful to the tractor, and indicates that the soil will not compress any further. In fact, additional time in that location may actually loosen the soil previously compacted.

Work as much area as possible from one position and overlap each compacted section slightly. The vibration frequency has been chosen to give maximum efficiency in granular soils using lifts of 2 to 4 feet. The closer the width of the trench is to the width of the compactor, the higher the delivered compactive effort.

GENERAL INSTRUCTIONS

The compactor is a device that uses available force to the best advantage. The DYNAMIC FORCE of the mass weight assembly, turning at a high rpm, produces a vibratory force, and with controlled placement, an impact force. The DOWN PRESSURE of the carrier on the compactor gives a high static pressure which assists in the compaction or driving. The vibration frequency is controlled by the hydraulic flow input to the compactor and is optimized for use in granular soils. The rate and density of compaction depends on such factors as moisture content of the soil, condition of the compactor and carrier, and the skill of the operator.

NOTICE

Efficient compactor performance is directly related to the flow rate specified. A higher flow rate does not improve performance. It results in fluid overheating, and contributes to early bearing failure. A lower flow rate causes reduced compaction performance.

The HS3000 Compactor delivers up to 3,400 lbs/1,542 kg of vibratory force. Its base plate covers a 17.5 x 20 in./44 x 51 cm area. It comes standard with a flow control to prevent overspeeding.

COMPACTION

GENERAL

The following instructions are very important to the proper performance of the compactor and the attainment of the specified compaction density.

It is necessary to turn the compactor OFF when being transported or sitting idle. Should the running compactor be placed on a hard surface without down pressure, the unit and the carrier will vibrate excessively. Down pressure transmits the vibration to the soil; neutral pressure will rattle the whole carrier assembly.

SLOPE TECHNIQUE

This method of compaction is of primary interest to a pipeline contractor seeking high production and efficient equipment utilization. The fill material is placed at one end of the trench and allowed to seek its own angle of repose. Compaction is begun on this angle above, but still near, the top of the pipe. All fill material is backfilled to this angle and the compactor is worked up and down the slope. Backfilling, compaction, and resurfacing can be done very shortly after the pipe is in place.

SOIL TESTING

Compaction density specifications are based on soil samples of a set moisture content and soil composition. Changing weather conditions, for example, can alter the moisture content of the fill being used, and may make meeting the specifications impossible. It is imperative that frequent and reliable tests be conducted during application of the compactor to determine the maximum lift that can be used and still provide the required density. It is important that lifts in excess of the established test results NOT be used if the required density is to be achieved and maintained.

DRIVING

Many driving jobs can be done with the compactor. Timber sheeting, steel and aluminum sheeting, H and I-beams, soldier piles and guard rail posts. The compactor will drive

OPERATION

these materials in most soil conditions, except solid rock or soil with a very high clay content.

The compactor is placed on the object to be driven using the front one-third (that portion of the baseplate furthest from the operator) of the baseplate. This position is critical to proper delivery of the compactor's vibratory force into the object. The front portion of the compactor will impart an impact or "slap" that will drive the material into the soil. The center portion of the compactor will "rock" on the material and provide very little impact force.

Apply down pressure evenly, but do not compress the shock mounts fully. Too much down pressure will make the compactor difficult to control on top of the driven object, and the impact required will be damped out.

⚠ WARNING

SERIOUS INJURY OR DEATH COULD RESULT FROM ATTEMPTING TO SUPPORT THE DRIVEN MATERIAL.

PERSONNEL WHO ATTEMPT TO SUPPORT THE DRIVEN MATERIAL CAN BE STRUCK OR CRUSHED.

DO NOT ATTEMPT TO SUPPORT THE DRIVEN MATERIAL.



One note of caution; the forces generated and the methods used while driving with a vibratory device preclude the calculation of "bearing loads" for a piling or sheet of material. **DO NOT USE THE COMPACTOR IN APPLICATIONS WHERE A BEARING LOAD IS SPECIFIED.**

TROUBLESHOOTING

If symptoms of poor performance develop, the following chart can be used as a guide to correct the problem.

PROBLEM	CAUSE	SOLUTION
Compactor Inoperative.	System Flow Valve not operating or adjusted incorrectly.	Adjust flow for compactor; flow and pressure test attachment circuit or compactor flow control, if installed.
	Seized bearings.	Replace bearings and perform flow and pressure tests.
	Kinked hose.	Replace.
	Plugged quick-disconnect	Repair or replace.
Rapid bearing failure.	Lack of lubrication.	Lubricate both bearings every 40 hours.
	Overspeeding.	Adjust flow for compactor; flow and pressure test attachment circuit or compactor flow control, if installed.
Rapid shock mount failure.	Excessive down pressure or carrier too large for compactor.	Compress shock mounts no more than 2-2.5 in./51-64 mm during operation.
	Cold weather operation.	Warm up according to Low-Temperature Warmup procedure.
Failure to achieve required compaction specifications.	Improper use.	See Operation section of this manual.
	Overspeeding or underspeeding of compactor.	Adjust flow for compactor; flow and pressure test attachment circuit or compactor flow control, if installed.
	Moisture/soil content incorrect for specified density..	Correct condition of soil, or compactor specifications are not reasonable for conditions.

FLOW TEST PROCEDURES

The correct performance of this procedure will verify if the auxiliary circuit of the carrier is adequate to properly operate a Stanley attachment.

This procedure is generic in form. It is the end users responsibility to ensure that this procedure will work with his specific type of equipment.

If an adequate flow meter is not available contact your Stanley Hydraulic Distributor for assistance.

TEST PROCEDURE

1. With the auxiliary circuit (or kit) completely installed connect the flow meter between the tool inlet and outlet hoses.

NOTE:

Always use the hoses that are supplied for the attachment and make sure the machine hydraulic oil is between 90° to 120° F. This will assure correct readings and adjustments.

2. With the machine setting at the mode that's going to be used to operate the attachment record the GPM _____.

Locate the correct flow for the attachment in the manual under the specification section. Adjust the machine to the correct GPM.

NOTE:

If possible, always set the machine to the highest GPM output mode. This will prevent the operator from over flowing the attachments.

3. Once the correct GPM flow is achieved fully open the restrictor on the flow meter.

4. With the machine in the attachment mode set in step 2 record the back-pressure. At this point the pressure reading on the pressure gauge is the back-pressure in the circuit. This pressure must not exceed 200 psi/13.5 bar.

Excessive back-pressure will slow the attachments operation and lead to premature seal failures and over heating.

Record the back-pressure _____ psi.

5. Close the restrictor valve on the flow meter until the attachment relief starts to crack or open. The relief valve opens when the flow rate (GPM), indicated on the flow meter begins to decline rapidly. Locate the tools operating system relief pressure in the specification section in the manual. Adjust attachment relief to specification.

NOTE:

The relief valve pressure must be greater than the operating pressure of the attachment and three times the back-pressure. Never use the relief valve to control the flow rate in the circuit. Cracking pressure means the loss of 4 or more GPM.

Record the relief cracking pressure _____ psi.

Example:

Operation pressure of a breaker is 2700 psi. Back-pressure is 150 psi. A good rule to follow when setting the relief, multiply the back pressure by 3 then add this number to the operation pressure of the attachment.

Operating Pressure	2700 psi
Back-pressure	450 psi
Operating pressure of the tool	3150 psi

The relief valve setting must be greater than the estimated operating pressure of the tool. If the setting is lower, damage to the circuit may occur. Excess heat will be generated in the circuit which will damage the attachment and carrier.

HEAT LOAD TEST

With the installation kit properly installed and adjusted per the above procedure, conduct the head load test as follows.

1. Connect the flow meter between the tool inlet and outlet hoses.

2. With the carrier set in the attachment mode, restrict the flow meter until a pressure of 1000 psi is achieved. This pressure must be maintained throughout the heat test.

NOTE:

Closing of the restrictor may be required as the temperature increases.

Monitor the oil temperature from the flow meter until no change is noted. Record the time required for oil to stabilize. Record the surrounding temperature (ambient temperature). Record the time required to stabilize _____ minutes.

Record the stabilized oil temperature _____ F.

Record the ambient temperature _____ F.

The "heat rise" is calculated as the stabilized temperature minus the ambient temperature.

FLOW TEST PROCEDURES

Example:

Stabilized Temperature	160°
Ambient Temperature	-80°
Heat Rise	80°

The normal operating temperature range of this circuit will be the typical ambient temperature range for the geographical area plus the heat rise calculated above. Ensure that the operating temperature range is lower than 180° for optimum operation of the attachment.

TROUBLESHOOTING

If adequate pump flow is available from the carrier pump(s) but is not getting to the attachment, consult your service representative and review the following:

1. Attachment valve(s) are not actuating. Review all electrical connections that are part of the attachment kit.
2. Ensure proper voltage to the valve(s).
3. Ensure the REG port of the valve is not blocked.
4. Check to make sure the carriers main relief is set to the manufacturers recommendation and that this value is equal or greater than the attachment circuit relief.
5. If the valve will not turn off, check the drain (tank) line of the valve to ensure that the pressure is 50 psi or less.

DEFINITION OF TERMS

Tool:	The hydraulic attachment which the auxiliary circuit is intended to power. These may include hydraulic breakers, compactors, shears, etc.
Operating Pressure:	That pressure at which the tool will naturally operate without influence of outside pressure relief mechanisms. This pressure is an operating characteristic of the tool and cannot be altered by the end user without changing the tool design.
Relief Pressure:	The relief pressure is that pressure at which the circuit will dump fluid in order to protect itself from damage.
Back Pressure:	The pressure at the tool's connection to the return circuit of the carrier.
Flow Meter:	Instrument for testing the operating characteristics of a hydraulic circuit. The data usually available from this device are pressure (psi/bar), flow (gpm/lpm) and temperature (°F/°C).
Restrictor Valve:	A valve on the flow meter which allows the user to simulate an operating tool by adding a pressure load (through restriction) to the circuit. This feature is used to evaluate relief settings and flow ratings at pressure.
V60/V65/V100 Valves:	A priority flow control valve manufactured by Stanley Hydraulic Tools. Allows for optimum operation of any attachment by providing the proper amount of flow for operation of the tool the "priority" aspect allows the attachment to function properly if another control function is activated.
Inlet Flow:	The hydraulic oil supplied to the "IN" port of the tool or valve.
Regulated Flow:	The flow of oil supplied to the tool by the V60/V100 valve.
By-Pass Flow:	The oil flow that is supplied by the carriers pump, but not used in the operation of the attachment. By-pass flow equals inlet flow (to the valve) minus the regulated flow.
Pressure Line:	The hydraulic line(s) which supply pressurized oil from the pump to the valve or tool.
Return Line:	The hydraulic line which connects the "OUT" port of the tool to the tank circuit of the carrier.
Cracking Pressure:	The pressure at which the relief valve starts to open. Can be seen by a drop in the flow rate as shown by the flow meter.
Full Open Pressure:	The pressure at which the relief valve is completely open dumping all system flow to the tank.
Ambient Air Temperature:	The temperature of the outside air.
Stabilized Temperature:	The temperature at which the carrier hydraulic system temperature will stop rising during testing or operation.

SPECIFICATIONS

Performance

Centrifugal Force	3400 lb/1542 kg
Developed Frequency	2100 vpm

Dimensions and Weights

Spread Between Pins	9 & 14 in./22.9 & 35.6 cm
Baseplate Size	17.5 x 20 in./44 x 51 cm
Overall Length	25.5 in./65 cm
Width Inside Bracket	10.25 in./26 cm
Overall Width	17.5 in./44 cm
Overall Height	18.5 in./47 cm
Weight	370 lb/168 kg
Standard Mounting Pin Diameter	Universal*

*Contact your dealer for appropriate mounting hardware for your application.

Hydraulic Requirements

HS3004F & HS3100 Models

Minimum Carrier Flow	12 gpm/45 lpm
Maximum Carrier Flow	25 gpm/95 lpm
Optimum Carrier Flow	13 gpm/49 lpm
Compactor Flow	9 gpm/34 lpm
Normal Operating Pressure	1600-2000 psi/110-138 bar
Back Pressure	Not to Exceed 250 psi/17 bar
Relief Setting	2500 psi/172 bar

HS3101 Model

Minimum Carrier Flow	8 gpm/30 lpm
Maximum Carrier Flow	20 gpm/75 lpm
Optimum Carrier Flow	9 gpm/34 lpm
Compactor Flow	9 gpm/34 lpm
Normal Operating Pressure	1600-2000 psi/110-138 bar
Back Pressure	Not to Exceed 250 psi/17 bar
Relief Setting	2500 psi/172 bar

Miscellaneous

Flow Meter	29085
------------------	-------

NOTE: Weights, dimensions and operating specifications listed on this sheet are subject to change without notice. Where specifications are critical to your application, please consult the dealer.

SPECIFICATIONS

TORQUE TABLE				
General Item No.	Description	Apply	Ft/Lb	Nm
2	HHCS 1/2-13 UNC Grade 8	Anti-Seize	35	47
18	HHCS 3/8-16 UNC Grade 5	Anti-Seize	23	31
22	Split Flange Capscrews	Anti-Seize	18	24
26	HHCS 1/2-13 UNC Grade __	Anti-Seize	85	115
30	HHCS 3/8-16 UNC Grade 8	Anti-Seize	18	24
34	HHCS 5/8-11 UNC Grade 5	Anti-Seize	180	244

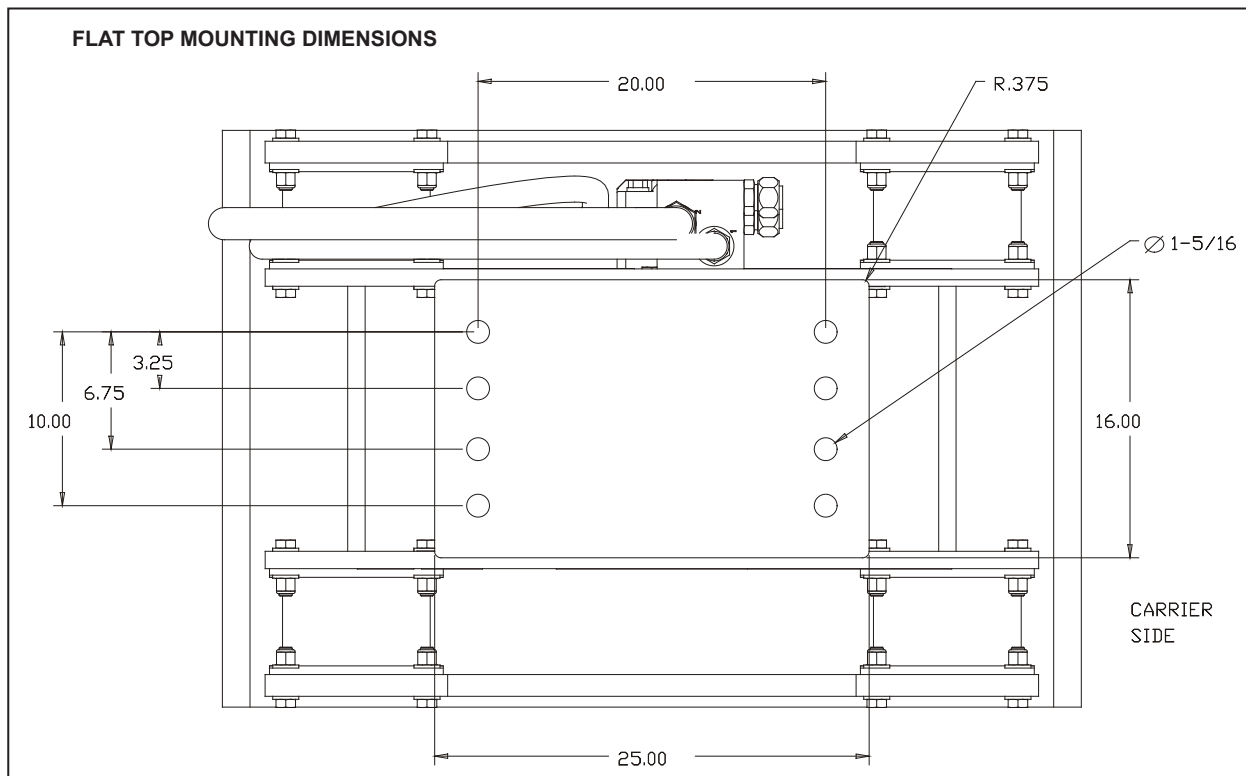

NOTE: Weights, dimensions and operating specifications listed on this sheet are subject to change without notice. Where specifications are critical to your application, please consult the dealer.

HS3000 PARTS ILLUSTRATION

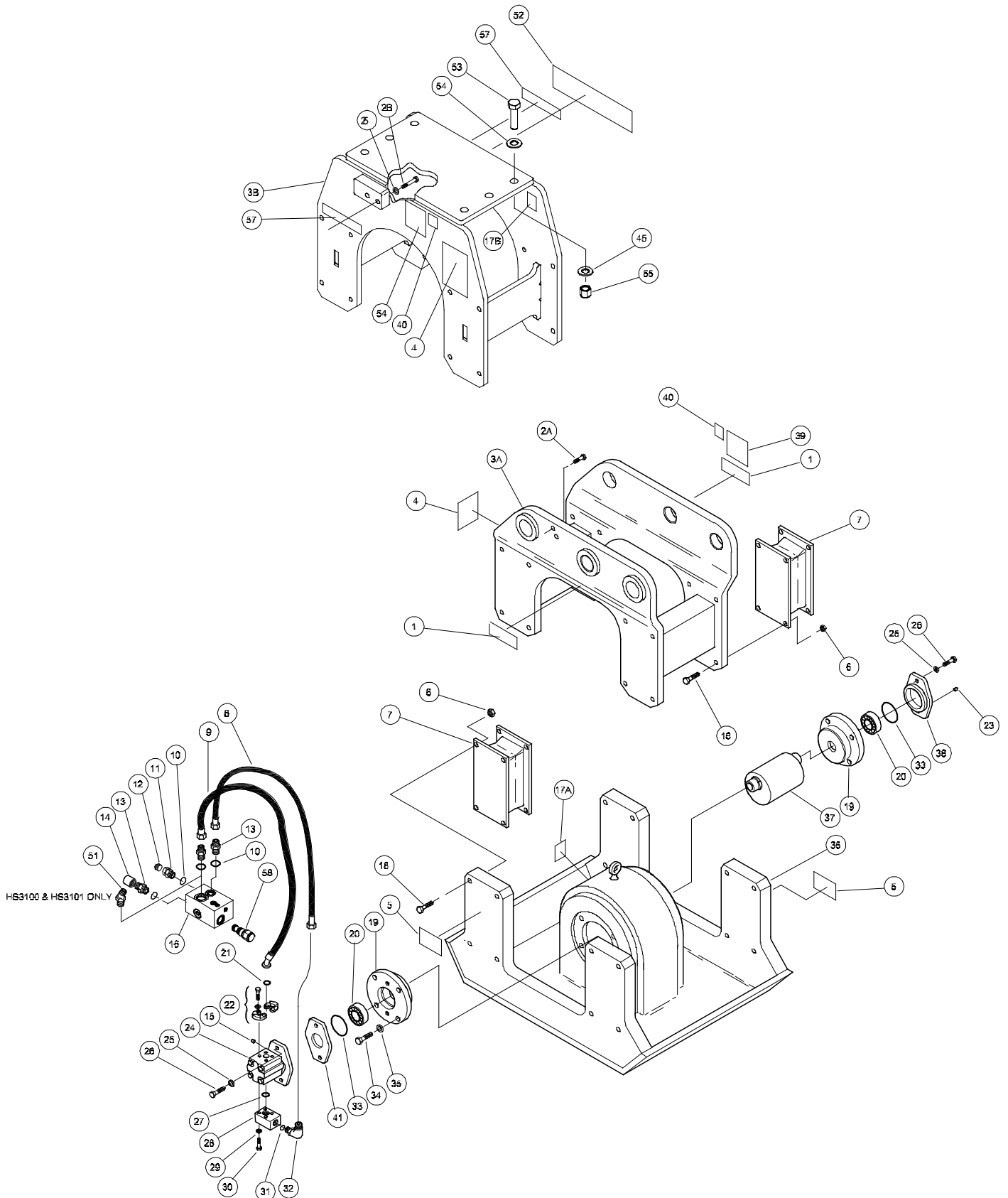

HS3000 PARTS LIST

Item	Part No.	Qty	Description
1	18968	2	Decal, HS3004
2A	04661	2	Capscrew (3004F)
2B	20382	2	Capscrew (HS3100& HS3101)
3A	35792	1	Upper Frame Weldment (HS3004F)
3B	65719	1	Upper Frame Weldment (HS3100 & HS3101)
4	47351	1	Decal, Composite Safety (HS3004F, HS3100)
5	05152	2	Decal, Stanley
6	04353	32	Nut
7	12079	4	Shock Mount
8	35788	1	Hose Assy (HS3004F)
	65729	1	Hose Assy (HS3100 & HS3101)
9	35789	1	Hose Assy
10	06891	4	O-ring
11	02112	1	Adaptor
12	25109	1	Plug
13	2773	--	Connector (1 for HS3004, 2 for HS3100 & HS3101)
14	28841	--	Cap (1 for HS3004, 2 for HS3100 & HS3101)
15	372003	1	Grease Fitting 45°
16	35704	1	Hose Block Assy (HS3004F & HS3100)
	65733	1	Hose Block Assy (HS3101)
17A	47352	1	Decal, Pick Point (HS3004F)
17B	47352	2	Decal, Pick Point (HS3100 & HS3101)
18	02099	32	Capscrew
19	206028	2	Bearing Carrier
20	206019	2	Bearing
21	06891	1	O-ring
22	350215	1	Split Flange Kit (HS3004F, HS3100)
	10289	1	Split Flange Kit (HS3101)
23	372003	1	Grease Fitting
24	22061	1	Motor (HS3004F, HS3100)
	22060	1	Motor (HS3101)
25	371050	6	Washer
26	02504	4	Capscrew
27	00834	1	O-ring
28	206029	1	Inlet Manifold (HS3004F, HS3100)
	10272	1	Inlet Manifold (HS3101)
29	371056	4	Washer (HS3004F & HS3100)
	02634	4	Washer (HS3101)
30	370155	4	Capscrew (HS3004F & HS3100)
	02665	4	Capscrew (HS3101)

Item	Part No.	Qty	Description
31	1605	1	O-ring
32	4860	1	Elbow
33	6330	2	O-ring
34	370352	8	Capscrew
35	371061	8	Washer
36	35245	1	Shoe Weldment
37	12669	1	Mass Weight Assy
38	206024	1	Bearing Cover
39	58887	1	CE Plate (HS3004F)
40	-----	--	NO ITEM
41	21896	1	Mount Adapter, M30 Motor
42	-----	--	NO ITEM
43	-----	--	NO ITEM
44	-----	--	NO ITEM
45	-----	--	NO ITEM
46	-----	--	NO ITEM
47	-----	--	NO ITEM
48	-----	--	NO ITEM
49	-----	--	NO ITEM
50	----	--	NO ITEM
51	04328	1	45° Elbow (HS3100 & HS3101)
52	09163	1	Decal, Stanley (HS3100 & HS3101)
53	370353	6	Capscrew (HS3100 & HS3101)
54	20876	12	Washer (HS3100 & HS3101)
55	371514	6	Nut (HS3100 & HS3101)
56	65730	1	Decal, CE (HS3100)
	65731	1	Decal, CE (HS3101)
57	12686	2	Decal, HS3000 (HS3100 & HS3101)
58	35702	1	Cartridge
	206020	1	Motor Seal Kit 9 gpm Motor (Commercial Intertech)
	21654	1	Motor Seal Kit 13 gpm Motor
	67936	1	Motor Seal Kit (Permco)



Stanley Hydraulic Tools
3810 SE Naef Road
Milwaukie, Oregon 97267
503-659-5660 / Fax 503-652-1780
www.stanleyhydraulic.com

IMPORTANT

To fill out a Product Warranty Recording form, and for information on your warranty, visit Stanleyhydraulic.com and select the Warranty tab.
(NOTE: The warranty recording form must be submitted to validate the warranty).