



Safety, Operation & Maintenance Manual

MSD Saber Series™ Shears

Part Number 512141

STANLEY



INTELLECTUAL PROPERTY – PATENT INFORMATION

This product is covered by one or more of the following patents.

U.S. PATENT NUMBERS:

5,474,242	7,240,869
5,531,007	7,487,930
5,992,023	7,578,461
7,322,273	7,832,130
8,146,256	8,104,384

EPO Patent Numbers

435,702
737,107
1,682,299
1,789,225

PREFACE

This manual contains information for the safe and proper operation and maintenance of MSD Mobile Shears. Read the entire manual before the initial start-up of the attachment. It is important to know the correct operating procedures of the attachment and all safety precautions to prevent the possibility of property damage and personal injury.

The LaBounty attachment has been designed and manufactured with high quality materials and care in workmanship. The instructions in this manual have been prepared to ensure that, when followed properly, the attachment will provide efficient and reliable service. Continuing product development and improvement may have caused changes in the attachment that are not reflected in this manual. If a question arises regarding the operation or maintenance of the attachment, contact a LaBounty dealer for the most current information available.

COPYRIGHT © 2012

TABLE OF CONTENTS

SECTION 1 INTRODUCTION TO SAFETY

Introduction	1-2
Understand Signal Words	1-2
Safety Summary	1-3
Attachment Decals	1-5

SECTION 2 ABOUT THE ATTACHMENT

Model Description	2-2
Features.....	2-2
Attachment Terms.....	2-3
Attachment Glossary	2-4
Flow and Pressure Requirements	2-7

SECTION 3 INSTALLATION

Shear Mounting Procedure.....	3-2
Mobile Shear Start-Up Procedure	3-4
Shear Removal Procedure	3-5
Shear Storage	3-5
Internal Rotation Control System Installation (if equipped).....	3-6
Electrical Installation- Internal Rotation Control System.....	3-6
Electrical Schematic- Internal Rotation Control System	3-7
Hydraulic Return Line Installation Instructions- Internal Rotation Control System	3-8
Hydraulic Schematic- Internal Rotation Control System	3-9

SECTION 4 OPERATION

Before You Start	4-2
First Things First	4-2
Safety Devices You'll Need	4-2
General Rules for Safe Operation	4-3
Mobile Shear Controls	4-4
Operating the Rotator.....	4-6
Backdriving the Rotator	4-6
Operating the Internal Rotation Control System.....	4-6
Recharging the Accumulator with Fluid.....	4-6
Speed Valve Operating Characteristics	4-7
Getting the Feel of the Attachment.....	4-7

SECTION 5 MAINTENANCE

Scheduled Maintenance	5-2
Recommended Spare Parts List.....	5-3
Maintenance Safety Procedures.....	5-4
General Rules for Maintenance	5-4
8-Hour Service Recommended	5-5
80-Hour Service Recommended	5-5
2000-Hour Service Recommended.....	5-5
8-Hour Inspection Checklist	5-6
80-Hour Inspection Checklist	5-7
8-Hour Inspection Rotator Checklist.....	5-8

TABLE OF CONTENTS

SECTION 5 MAINTENANCE continued

Lubrication	5-9
Bolt Torque Guidelines	5-10
Metric Capscrew Size Guide	5-10
Torque Values for Metric Fasteners.....	5-11
Slide Screw Maintenance	5-12
Blade Removal.....	5-14
Blade Bolt Torque Specifications.....	5-15
Torque Values for Blade Bolts.....	5-15
Guide Blade Shimming and Rotation	5-16
Cutting Blade Rotation Procedure	5-17
Weld-in Tip Cutting Blade Rotation Procedure.....	5-21
Cutting Blade Shimming.....	5-22
General Guidelines for Build-up and Hardsurfacing	5-23
Build-up Recommendations	5-24
Hardsurfacing Recommendations	5-24
Critical Wear Areas.....	5-26
Upper Shear Build-up and Hardsurfacing	5-27
Weld-in Tip Maintenance	5-28
Weld-in Tip Replacement.....	5-30
Front Wear Plate Replacement	5-32
Lower Wear Plate Replacement	5-33
Lower Shear Build-up and Hardsurfacing.....	5-34
Hydraulic System Maintenance	5-37
Flange Type Hose Fittings.....	5-37
Torque Values for Four-Bolt Flange Fittings	5-38
Applying Split Flange Clamps	5-39
Cylinder Gap Check	5-40
Hydraulic Schematic- Standard Rotating Shears.....	5-41
Hydraulic Schematic- Standard Non-rotating Shears	5-41
Speed Valve Adjustment.....	5-42
Decal Maintenance.....	5-54

SECTION 6 ROTATOR MAINTENANCE

Major Components of Typical Rotation Systems	6-2
The Rotator	6-3
Bolt Torque.....	6-3
Torque Values for Turntable Bolts	6-3
Torque Values for Rotation Assembly Bolts.....	6-3
Planetary Gearbox Lubrication (if equipped)	6-4
Lubricant Change-out Procedure	6-4
Planetary Gearbox Lubricants	6-5
Synthetic Specification	6-5
Gearbox Fill Capacities	6-5
Turntable Bearing	6-6
Turntable Bearing Lubricants.....	6-6
Hydraulic Requirements	6-7
Rotation Control Valve Manifold.....	6-7
Case Drain	6-7

TABLE OF CONTENTS

SECTION 6 ROTATOR MAINTENANCE continued

Rotation Control Valve Assembly Schematics and Descriptions.....	6-8
Internal Rotation Control System (if equipped)	6-9
Accumulator Control Valve Assembly (if equipped)	6-10
Maintenance Intervals for Internal Rotation (if equipped)	6-11
Accumulator Maintenance.....	6-11
Testing the Accumulator Pre-charge.....	6-12
Pressure Release.....	6-12
Accumulator Pre-charging.....	6-12
Operating Flow for Internal Rotation	6-13
Operating Pressure for Internal Rotation	6-13

SECTION 7 TROUBLESHOOTING

Cutting Performance Troubleshooting Guide	7-2
Rotation Circuit Troubleshooting Guide.....	7-5
Internal Rotation Control System Troubleshooting Guide (if equipped).....	7-7
Speed Valve Troubleshooting Guide.....	7-10

Appendices

Bolt Torque Charts	A-1 (8-25)
Warranty	A-3

SECTION 1 INTRODUCTION TO SAFETY

Introduction	1-2
Understand Signal Words	1-2
Safety Summary	1-3
Attachment Decals	1-4

MSD SABER SERIES SHEARS

INTRODUCTION

Your safety and the safety of others is a direct result of how you operate and maintain your equipment. Read and understand this manual and other safety information provided with the base machine and be sure that you understand all controls and operating instructions before attempting to operate this equipment. Failure to follow the safety precautions can result in personal injury, death or property damage.

Carefully read all safety messages in this manual and on your equipment safety signs. Keep safety signs in good condition; replace missing or damaged safety signs.

Because LaBounty cannot foresee all hazardous circumstances, the precautions listed in this manual and on the equipment are not all-inclusive. If a procedure, method, tool or part is not specifically recommended by LaBounty, determine whether it is safe for you and others, and that the equipment will not be damaged or made unsafe as a result of your decision to implement it.

The basic rules are summarized in this section of the manual. They also appear throughout the manual along with additional specific rules for safety and operation.

UNDERSTAND SIGNAL WORDS

When you see the following symbols and signal words on your equipment or in this manual, be alert to the potential for personal injury or equipment or property damage. Follow recommended precautions and safe operating practices.



Indicates immediate hazards that WILL result in severe personal injury or death.



Indicates hazards or unsafe practices that CAN result in severe personal injury or death.



Indicates hazards or unsafe practices that could result in damage to the machine or personal injury.

NOTICE

Indicates notes of importance to a procedure or part.

SAFETY SUMMARY

⚠ DANGER

*If the attachment is not functioning properly, you **MUST** shut the machine down and follow proper lock-out, tag-out and repair procedures.*

⚠ DANGER

***NEVER** operate equipment without the original equipment safety guards in place. If the cab glass is missing or damaged, check with your dealer or manufacturer for proper replacement.*

⚠ DANGER

Ensure that the cab is equipped with the proper safety guards for LaBounty applications. In addition, it is required that the cab be equipped with an approved Falling Object Protection Structure (FOPS) when processing materials. The FOPS must meet the requirements of SAE standard J1356. A transparent shatter-resistant shield covering the front of the cab is also required. Contact your base machine equipment dealer or manufacturer for more information on the availability of FOPS. Lack of proper FOPS may result in injury or death.

⚠ DANGER

***DO NOT** process or handle material with the attachment over the operator's cab.*

⚠ DANGER

***DO NOT** attempt to shear brittle materials such as axles and railroad rail. Brittle material breaks or shatters instead of shearing. The material being processed could become a projectile and cause injury or death. **DO NOT** process any material in any position that may propel it toward operator, other workers, buildings or equipment.*

⚠ DANGER

***DO NOT** close the attachment on a structure and reverse the excavator in an attempt to pull down material.*

⚠ DANGER

*Clear all persons and equipment from the area of operation and machine movement. **NEVER** move loads over people or equipment. When viewing the operation of the attachment, maintain a safe distance of at least 75 feet (22.9 meters).*

⚠ DANGER

***NEVER** approach power lines with any part of the machine. Keep clear at a minimum of 15 feet (5 meters).*

⚠ DANGER

*Avoid tipping. The attachment will alter the lift capacities of the base machine. **DO NOT** overload the excavator or serious injury could result. Lift capacities will vary if the base machine is not on level ground. Carry loads in recommended positions for maximum stability. Use the recommended excavator counterweight. Use short slings and lift the load only as high as necessary.*

⚠ DANGER

***DO NOT** allow riders on the machine.*

⚠ DANGER

***NEVER** remove any pins unless the attachment is on the ground and blocked up or serious injury or death could result. Metal chips or debris may fly when a connecting pin is struck. Use a brass drift when striking pins and always wear protective clothing and proper eye protection. Pins may fly when struck with force to drive them in or out. Keep people clear when removing or installing pins.*

MSD SABER SERIES SHEARS

SAFETY SUMMARY continued

⚠ WARNING

Under no circumstances should any modifications be made to LaBounty equipment without factory authorization.

⚠ WARNING

ALWAYS lower the boom to the ground before leaving the cab. If it is necessary to work on an attachment off the ground, securely support the machine and attachment. DO NOT support the machine on cinder blocks, hollow tiles, or props that may crumble under continuous load. DO NOT rely on a cylinder to hold the attachment in the air. DO NOT work under a machine that is supported only by a jack.

⚠ WARNING

DO NOT let hot hydraulic oil get in contact with the skin as it could cause severe burns. Wear adequate protective clothing and safety equipment. DO NOT tamper with any hydraulic line or component while it is pressurized. Escaping fluid under pressure can penetrate the skin, causing serious injury. Relieve pressure before unhooking hydraulic or other lines. Tighten all connections before applying pressure. Keep hands and body away from pinholes and nozzles which eject fluids under high pressure. Use a piece of cardboard to search for leaks. If ANY fluid is injected into the skin, seek immediate medical assistance.

⚠ CAUTION

DO NOT weld on any structural member unless specifically authorized by LaBounty. Any unauthorized welding or welding procedures will void the warranty, and may cause structural failure or result in personal injury.

⚠ CAUTION

ALWAYS wear close-fitting clothing and safety equipment appropriate to the job. Safety equipment should be worn at all times when viewing, operating, or maintaining the attachment to prevent injury. Safety equipment includes eye protection, hard hat, steel toe shoes, gloves, and hearing protection.

⚠ CAUTION

Keep clear of all potential pinch points, including the moving upper jaw, cylinder connections, bucket linkages or other moving parts.

⚠ CAUTION

Before operating the attachment, read and observe all safety instructions in the Operation and Maintenance sections of this manual. If you are unfamiliar with any operation or maintenance procedure, seek instruction before proceeding.

ATTACHMENT DECALS

STANLEY



**STANLEY LABOUNTY BRAND DECALS
(REPLACEMENT DECALS AVAILABLE UPON REQUEST)
FIGURE 1-1**



**MODEL DECAL
FIGURE 1-2**

SAFETY FIRST

**Read the Safety, Operation and
Maintenance Manual before
operating or servicing the equipment.
Keep the manual with the attachment
so it is available for reference.**

**SAFETY FIRST DECAL PART NUMBER 503590
(INCLUDED WITH MANUALS)
FIGURE 1-3**

MSD SABER SERIES SHEARS

ATTACHMENT DECALS continued



GREASE DECAL
PART NUMBER 116338
FIGURE 1-4

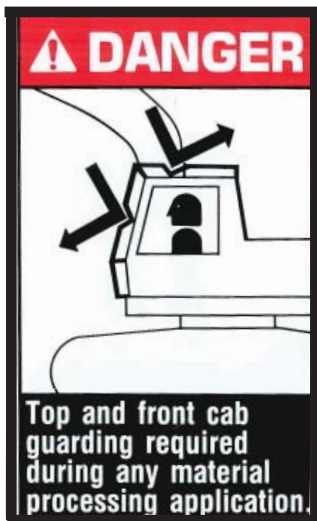

PATENT PLATE
PART NUMBER 116404
FIGURE 1-5



SAFE VIEWING DISTANCE DECAL
PART NUMBER 116389
FIGURE 1-6

	1538 HIGHWAY 2 TWO HARBORS, MN 55616 tel 1-800-522-5059 fax 1-218-834-3879 www.stanleyhydraulic.com	
Attachment Model:		
Serial Number:		
Year of Manufacture:		
Weight (lb./ kg):		
Made in the U.S.A. with Global Materials		

MODEL/SERIAL NUMBER PLATE
PART NUMBER 511045
FIGURE 1-7

U.S. PATENT NUMBERS		EPO PATENT NUMBERS
5,474,242	7,240,869	435,702
5,531,007	7,487,930	737,107
5,992,023	7,578,461	1,682,299
7,322,273	7,832,130	1,789,225
8,146,256	8,104,384	
STANLEY LABOUNTY		
1538 Highway 2		1-800-522-5059
Two Harbors, MN 55616		www.stanleyhydraulic.com
FOREIGN PATENTS AND OTHER PATENTS PENDING		
		
116404		

SAFETY DECAL
PART NUMBER 503647
FIGURE 1-8

SECTION 2 ABOUT THE ATTACHMENT

Model Description2-2
Features.....2-2
Attachment Terms.....2-3
Attachment Glossary2-4
Flow and Pressure Requirements2-7



MSD SABER SERIES SHEARS

MODEL DESCRIPTION

Since LaBounty® mobile shear technology was introduced, many changes have taken place. A wide selection of models and sizes are now available. Product refinements like 360° continuous rotation, high-performance reversed cylinders, tougher steels, and bolt-on replaceable wear parts have altered the look and improved the performance of LaBounty® Mobile Shears.

MSD Saber Series™ shear models are currently available for base machines with operating weights from 20,000- 280,000 lbs (9091 – 130,000 kg) with a range of cutting depths. Both rotating and non-rotating models are available. Rotating models feature hydraulically-powered 360° continuous rotation. This option allows the shear jaws to be positioned to cut at virtually any angle.

MSD Saber Series™ models feature a cylinder-mounted speed valve to decrease cycle times and increase efficiency. This patented, spool-type valve design has proven significantly more dependable than cartridge-type regenerative systems favored by other mobile shear manufacturers. These shears feature high-strength, abrasion-resistant steel



FEATURES

- Patented wear parts system for increased efficiency and less downtime for maintenance
- Dependable spool-type speed valve technology to decrease cycle times
- Maximum cutting strength and reach with minimal weight
- Optimum reach reduces machine movement and wear; greatly reduces the need for stick mounting and increases safety
- Made with high-strength, abrasion-resistant steel for durability
- Four-way indexable blades
- Installs in as little as two hours
- At-factory upgrading and rebuilding services available for extended life

OPTIONS

- 360° continuous rotation
- Magnet lifting eye
- Auxiliary hydraulic kit for rotation circuit

construction to assure long, uninterrupted service – even in the harshest conditions. The main pivot shaft of every model is manufactured for long life and pivots on Stanley LaBounty's specially designed bearings. These shears are designed to draw the material into the jaws to the point where the shear force is greatest, making them the most efficient cutting tool possible.

Mobile shears can cut a wide variety of materials including I-beams, H-beams, channel iron, steel plate, pipe, round stock, wire, rebar, concrete, etc. They are ideal for scrap processing, demolition work, road and bridge reconstruction, and jobs where torching is not feasible or possible.

ATTACHMENT TERMS

ROTATOR

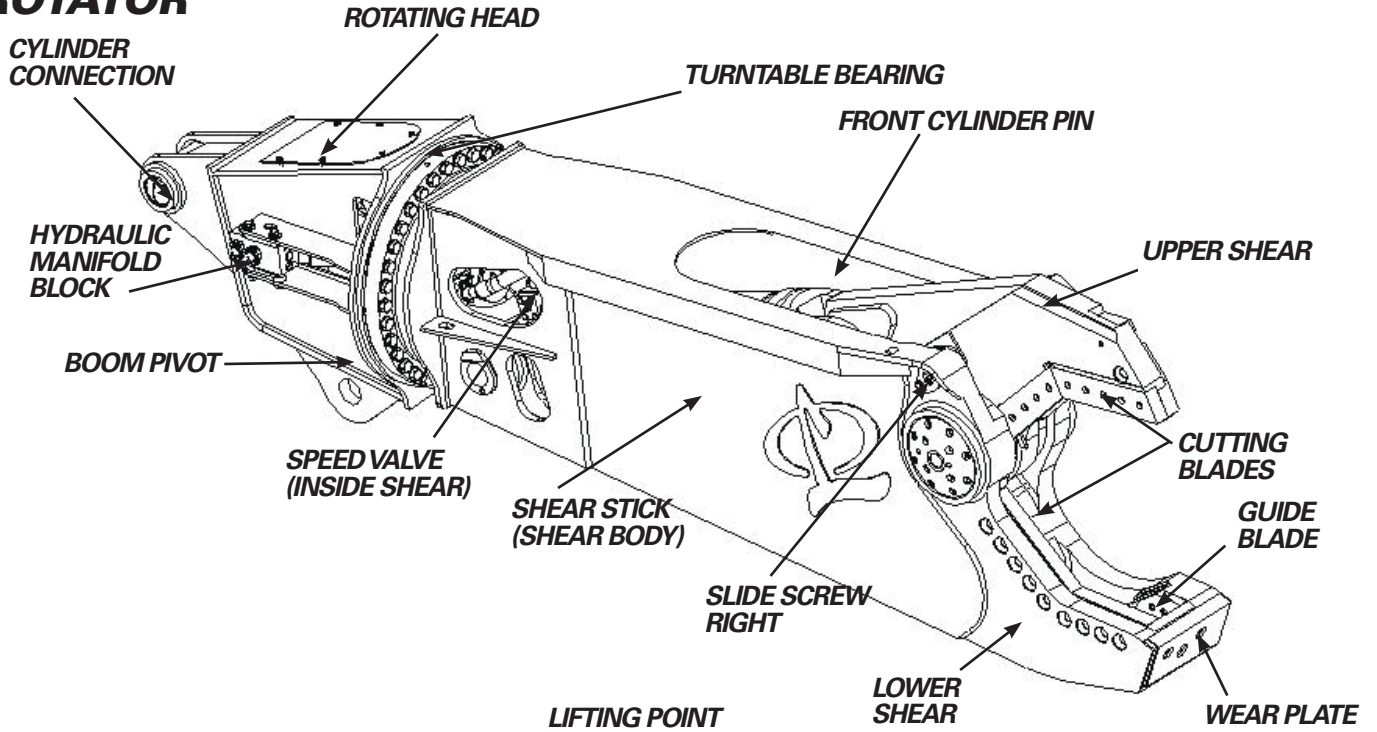

NON-ROTATOR

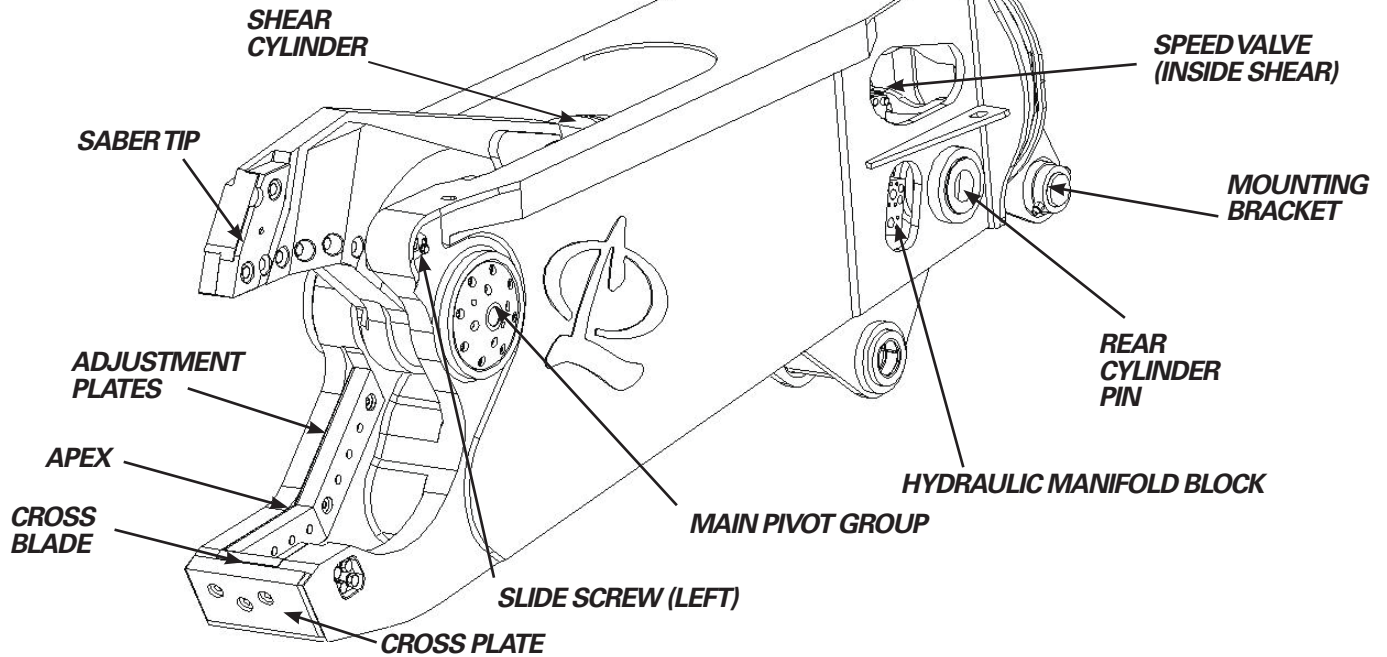

MSD SABER SERIES SHEARS

ATTACHMENT GLOSSARY

Accumulator	Used in a hydraulic rotation kit to store hydraulic fluid to drive the rotation motor.
Adjustment Plates	Custom-made plates that precisely adjust the lower cutting blades to the upper blades. These plates make it possible to achieve a uniform blade gap on the shear.
Apex	The point where the primary and secondary cutting blades come together.
Blade Gap	The gap between the upper and lower cutting blades as the blades bypass. A very important item that must be maintained regularly to prevent material from jamming in the blades.
Blade Shims	Thin metal shims used to adjust the position of the lower cutting blades to maintain a proper blade gap. Blades should never be shimmed out farther than 0.13" (3.3 mm).
Boom Pivot	Part of the shear mounting bracket that attaches to the excavator's boom tip (second member mounts).
Build Up	Welding process where worn off parent material is replaced with new metal. A very important maintenance procedure that must be performed regularly throughout the life of the shear.
Control Valve Manifold	Used in the hydraulic rotation kit to direct flow to the accumulator and back to the hydraulic motor.
Cross Blade	A replaceable component located on the inside of the lower shear cross plate. The cross blade is an easy-to-replace wear part that reduces maintenance time in the piercing area.
Cross Plate	Plate located at the front of the lower shear which ties the two halves of the lower shear together. The cross blade is contained in the cross plate. Requires regular build-up and hardsurface.
Crossover Relief Valve	A hydraulic component used in a rotating shear that limits the amount of hydraulic pressure sent to the rotation assembly. The crossover is preset at the factory and must not be tampered with.
Cutting Blades	The blades in the upper and lower shear jaws that shear materials as they bypass. The primary blades are those in the upper and lower jaws that are nearest to the shear throat. The secondary blades are those that are farthest from the shear throat.
Cylinder Connection	Part of the shear mounting bracket that articulates the tip-up function of the shear. The cylinder connection attaches to the excavator's stick cylinder (second member mounts).
End Cap	Protects and adjusts the main pivot group of the shear. The end cap is a vital component to the adjustment of the main pivot group and must not be removed without first consulting the LaBounty Customer Service Department.
Flow Control Valve	A hydraulic component used in a rotating shear that meters out the hydraulic fluid from the rotation motor. The flow control should be set to limit the rotator from spinning faster than 1- 2 revolutions per minute.
Front Cylinder Pin	The pin that attaches the shear cylinder barrel end to the upper shear.
Grain of Material	The direction that the parent material was initially rolled at the steel mill. It is very important when hardsurfacing any part of the shear to weld with the grain of the steel. Cross-grained hardsurfacing has the tendency to start cracks in the base material.

ATTACHMENT GLOSSARY continued

Guide Blade	A replaceable component located opposite the cutting blades in the lower shear. The main purpose of the guide blade is to support the upper shear during the cutting cycle. This is a very important maintenance item.
Guide Blade Shims	Thin metal shims used to adjust the guide blade out to maintain the proper guide blade gap. Shims come in a designated set that determines when the guide blade will be indexed or replaced.
Guide Blade Gap	The gap between the front wear plate and the guide blade as the upper shear is cycled into the lower. This is an important maintenance item to ensure longevity of the shear's structure.
Hardsurface	Welding process for protecting the parent material of the shear jaws. The hardsurface acts as a wear surface.
Hub Shims	Thin metal, circular shims used in the main pivot group of LaBounty shears. Hub shims provide factory adjustment of the upper shear for close blade tolerance.
Lifting Points	Small holes in the top of the shear to be used when mounting or transporting the shear. There are two holes near the front of the shear and one lug at the rear. These points must never be used for cable hanging the shear for cutting operations.
Lower Piercing Area	The frontal area of the lower shear through which the upper piercing tip passes. This area contains the guide blade and the cross blade.
Lower Shear	The lower stationary jaw of the shear. The lower shear contains the lower cutting blades, the guide blade, and the cross blade.
Lower Wear Plates	Replaceable, abrasion-resistant wear plates that protect the cross plate of the lower shear.
Main Bearing	Hardened bushings that the main shaft of the shear rotates on during operation. There are two main bearings, bolted in on both sides of the main pivot group.
Main Pivot Group	High tolerance area of the shear that contains the two main bearings, two thrust washers, main shaft, hub shims and two end caps.
Main Shaft	The shaft on which the upper shear pivots causing the shearing action of the attachment.
Manifold Block	Hydraulic block that directs the excavator's hydraulic flow to the shear cylinder and rotation assembly.
Motor	Hydraulic rotation component that drives the turntable bearing or planetary gear box on rotating shears.
Mounting Bracket	The bracket at the rear of the shear that allows it to be attached to the excavator. For a typical second member mount, the mounting bracket pins to the excavator boom tip and stick cylinder.
Planetary Gear Box	Hydraulic rotation component on larger rotating shears. The planetary gear box rotates the body of the shear with hydraulic motor. The output shaft of the component directly drives the turntable bearing of the rotating shear.
Rear Cylinder Pin	Pin that connects the rod end of the shear cylinder to the rear of the shear. The rear cylinder pin must be greased according to the required maintenance.

MSD SABER SERIES SHEARS

ATTACHMENT GLOSSARY continued

Rotation Assembly	Hydraulic drive assembly allows full 360° continuous rotation of the shear. This option gives greater positioning capabilities when processing with the mobile shear.
Saber Tip	Bolt-on, two-way indexable piercing tip/wear plate found at the top of the upper jaw.
Shear Cylinder	Hydraulic cylinder that powers the cutting action of the shear. The barrel end of the cylinder attaches to the shear's upper jaw and the rod end attaches to the rear cylinder lugs. The cylinder rod stays protected from damage inside the shear.
Shear Stick	The main body of the shear that includes the lower shear. This weldment must be regularly inspected for damage.
Slide Screw	Adjustable components installed through both sides of the stick. Aligns and supports the upper shear for a uniform blade gap.
Speed Valve	Regenerative hydraulic valve mounted on the cylinder of LaBounty® MSD Saber Series shears that increases the shear closing speed (cylinder extend function) when the shear is not under a load, thereby reducing cycle times and increasing efficiency. Stanley LaBounty uses a spool-type speed valve design for better durability over cartridge-type regenerative valves.
Swivel Manifold	Allows continuous hydraulic flow to the shear cylinder during rotation of shear without twisting hoses.
Thrust Washer	Main pivot group component that is located inside the end caps as a wear part for the main shaft.
Tie Rod	Rod that extends through the center of the main pivot group. The tie rod adds lateral support to the main pivot group.
Throat	Area of both the upper and lower jaw near the main pivot where the primary blades are located. The throat area is the optimum area for shearing material. The shear is most powerful on the primary blades nearest the pivot point.
Turntable Bearing	Rotary gear bearing used in rotating shears. It is mounted to the shear stick and is driven by hydraulic components in the upper head or mounting bracket. This bearing is sometimes called a slewing ring.
Upper Head	Mounting bracket portion of a rotating shear. Attaches to the turntable bearing that attaches to the rear of the shear stick. The upper head contains the hydraulic manifolds and the swivel manifold.
Upper Shear	Movable jaw of the shear that contains cutting blades, the Saber Tip™, and the wear area for the slide pucks. The shear cylinder articulates the upper shear into the lower shear to perform the cutting action of the shear.
Wear Parts	Consists of the cutting blades, guide blade, cross blade, and Saber Tip™. These parts can be easily replaced to refresh the System wear areas of the shear jaws. Dramatically increased surface areas on these wear parts provide better wear and less downtime for maintenance.

FLOW AND PRESSURE REQUIREMENTS

The following table provides the MSD Saver Series Mobile Shear flow and pressure requirements for the open and close function. Please note that all models include speed valves; also note that these calculations are theoretical and that actual cycle times will vary depending upon the specific excavator's hydraulic efficiency, possible back pressure in the system, operator competency, etc. These cycle times are calculated with not material in the jaws. The cycle times will be longer when maximum shear force is required (shear will go out of "speed valve mode").

SHEAR MODEL	RECOMMENDED PRESSURE RANGE	SHEAR FORCE	REQUIRED FLOW (GPM) TO MEET 8, 10, 12, AND 14 SECOND CYCLE TIMES			
			8 SEC	10 SEC	12 SEC	14 SEC
MSD 1000	4000- 5500 PSI (276-379 BAR)	690	50	40	--	--
MSD 1500		920	60	48	40	--
MSD 2000		1160	110	90	70	60
MSD 2500		1500	150	130	110	94
MSD 3000		1900	160	140	120	103
MSD 4000		2400	--	175	150	128
MSD 4500		2600	200	175	150	128
MSD 7500		3100	--	241	201	172
MSD 9500		4110	--	350	292	250

NOTICE

- *Rotation Circuit- 8-12 GPM @ 2000- 2500 PSI. A 1/2" case drain line going from the hydraulic rotation motor to the excavator's hydraulic tank is required to relieve back pressure.*
- *Pump summation or dual pump flow is recommended for shear munting second-member on most excavators. Due to the increase in flow, there may be a requirement to add larger hydraulic lines or dual lines up the boom to minimize back pressure, reduce heat and maximize shear performance.*

SECTION 3 INSTALLATION

Shear Mounting Procedure..... 3-2
Mobile Shear Start-up Procedure..... 3-4
Shear Removal Procedure 3-5
Shear Storage 3-5
External Rotation Control System Installation (if equipped)..... 3-6
Electrical Installation- Internal Rotation Control System 3-6
Electrical Schematic- Internal Rotation Control System 3-7
Hydraulic Return Line Installation Instructions Internal Rotation Control System..... 3-8
Hydraulic Schematic- Internal Rotation Control System 3-9



MSD SABER SERIES SHEARS

SHEAR MOUNTING PROCEDURE

Take note whether yours is a second member or a third member installation. A second member mount is where the shear replaces the excavator stick; a third member mount is where the shear replaces the bucket.

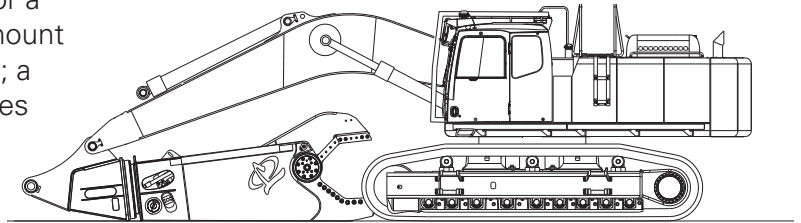

FIGURE 3-1

1. Place the shear upside down on the ground with blocking to keep the shear level. Locate flat, hard ground for installation.
2. For a second member mount, remove the excavator stick following the manufacturer's recommended procedure.
3. For a third member mount, remove the bucket or other attachment following manufacturer's recommended procedure. To prevent contamination of the hydraulic system, plug the hydraulic hose when they are disconnected.

NOTICE

It may be necessary to lift the rear of the shear into position to allow boom pivot pin installation on second member mounts.

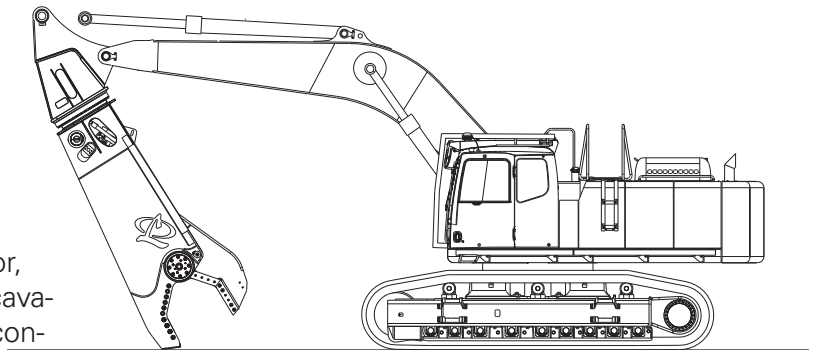
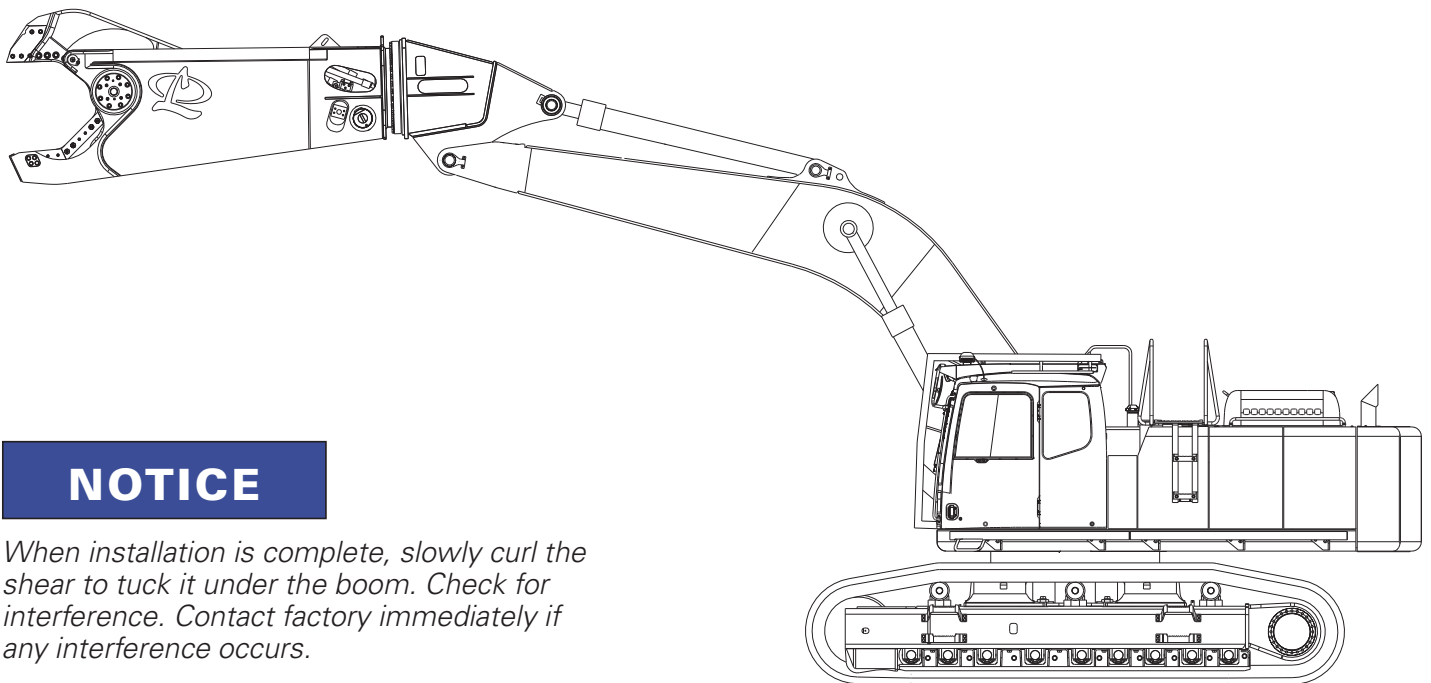

FIGURE 3-2

4. With the jaws of the shear facing the excavator, walk the excavator into position, aligning the excavator's boom or stick into the boom pivot or stick connection of the shear bracket (see **Figure 3-1**).
5. For second member mounts, pin the shear boom pivot to the excavator boom using the excavator boom pin (second member). For third member mounts, pin the stick tip to the stick connection using the pin provided by LaBounty.
6. Instruct the operator to slowly pick the shear up into a position where there will be enough clearance to pin the other connection of the shear mounting bracket (see **Figure 3-2**).

SHEAR MOUNTING PROCEDURE continued

7. Extend the cylinder rod or bucket linkage and move into position as necessary to pin this connection. Install shear supplied pin. It may be necessary to use a lifting device (overhead hoist, forklift, etc.) to position the cylinder or linkage correctly.
8. Connect the hydraulic hoses to the manifold located on each side of the head. Remember to cap all hydraulic hoses and fittings immediately to prevent contamination of the hydraulic system. Tighten the bolts to the proper torque (refer to Split Flang Fitting Torque Tables on page 8-26).
9. On rotating models the following procedures are to be followed.
 - a. After installing a hydraulic circuit on the excavator, install additional hydraulic lines up the boom—these will include two 1/2" (13 mm) diameter feed lines and one 1/2" (13 mm) diameter case drain line. These will terminate at the end of the boom.
 - b. Install jump lines from the above hydraulic lines to the shear bulkhead or manifold fittings. Please refer to the parts catalog for specific flow and pressure requirements; if in doubt, call Service (800-522-5059).
10. Check to make sure all collars, fasteners, and other connecting hardware are secure before proceeding.
11. Lift the boom and slowly try the shear rotate function and shear open and close function (see **Figure 3-3**). Watch for hydraulic oil leaks.



NOTICE

When installation is complete, slowly curl the shear to tuck it under the boom. Check for interference. Contact factory immediately if any interference occurs.

FIGURE 3-3

MSD SABER SERIES SHEARS

MOBILE SHEAR START-UP PROCEDURE

Air must be bled out of the cylinder prior to operation of the shear. Trapped air in the system leads to cavitation, oxidation of the oil, and excessive heat. These conditions promote hydraulic oil break down, contamination, noise, sluggish operation, reduced component life and potential cylinder damage. This procedure will need to be followed upon installation, after hydraulic repairs have been made, or when a shear has been stored or idle for an extended period of time. Make sure the shear cylinder is either fully retracted or extended—if not, mechanically place into either of these positions (loosen end plugs or caps on the manifold or fittings to relieve air pressure to the shear cylinder. Position the shear so the cylinder is as horizontal as possible. Set the excavator at idle speed or slightly above idle speed.

WITH CYLINDER FULLY RETRACTED

1. Slowly fill the rod end of the cylinder (open the shear) until a noticeable change in tone of the excavator is heard, indicating full cylinder. **Do not operate to the machine's full operating pressure.**
2. Change direction of oil flow; slowly fill the bore end of the cylinder (close the shear) until the rod is extended approximately 1/4 of stroke.
3. Retract the cylinder rod all the way.
4. Repeat steps 2 and 3, extending rod to approximately 1/2 stroke, then 3/4 stroke, then full stroke.
5. When cylinder is full of oil, slowly cycle cylinder rod back and forth at least five times through full stroke. **Do not operate to the machine's full operating pressure.**

WITH CYLINDER FULLY RETRACTED

1. Slowly fill the bore end of the cylinder (close the shear) until a noticeable change in tone of the excavator is heard, indicating full cylinder. **Do not operate to the machine's full operating pressure.**
2. Change direction of oil flow; slowly fill the rod end of the cylinder (open the shear) until the cylinder rod is retracted approximately 1/4 stroke.
3. Extend the cylinder rod all the way.
4. Repeat steps 2 and 3, retracting cylinder rod to approximately 1/2 stroke, then 3/4 stroke, then full stroke.
5. When cylinder is full of oil, slowly cycle cylinder rod back and forth at least five times through full stroke. **Do not operate to machine's full operating pressure.**
6. Slowly cycle the cylinder five or more times reaching machine's normal operating pressure at end of each stroke, open or close. Listen for unusual noise and check for any hydraulic leaks.

NOTICE

After the cylinder has been bled and drained of air, check the excavator hydraulic fluid and fill to the proper level.

MOBILE SHEAR REMOVAL PROCEDURE

1. Position shear under the boom of the excavator as far as the stick cylinder will extend and lower shear to the ground.
2. Use blocking to support the stick cylinder from the excavator boom.
3. Remove the stick cylinder pin from the shear mounting bracket.
4. Fully retract the stick cylinder as it is unattached from the shear mounting bracket.
5. Cycle the upper jaw closed far enough to allow the upper to lay flat on the ground with the rest of the shear. The object of this is to create as many possible shear contact points with the ground.
6. Cycle all controls with the excavator off to relieve any trapped pressure.
7. Carefully remove the jump-lines at the shear manifold.
8. Plug the open manifold ports and hose ends with pressure plugs to prevent contamination of the hydraulic system.
9. At this point, be extremely sure that the shear is stable and tension to the boom pivot pin is released before unpinning the boom pivot pin and releasing the weight of the shear.
10. Remove the boom pivot pin from the shear.

SHEAR STORAGE

1. Block the shear up off the ground using wood blocking.
2. Grease the pins and machined bores of the mounting bracket of the attachment. Apply a generous amount of grease to the shear blades, cylinder rod and all other exposed unpainted surfaces.

NOTICE

Watch the boom to attachment pivot for any interference. If interference is present DO NOT force the attachment under any further. Block the attachment up before it interferes with the boom, or stop.



Figure 3-4



See Figure 3-4. Trapped hydraulic pressure may be present after the base machine is shut off. Extreme caution must be taken when removing attachment hydraulic hoses or possible injury or death could result.

MSD SABER SERIES SHEARS

INTERNAL ROTATION CONTROL SYSTEM INSTALLATION

if equipped

BEFORE GETTING STARTED

1. Have the Parts Catalog for the shear and the installation manual on hand for reference. The parts information for the Internal Rotation Control System is included in it.
2. Check if the following items exist on the base machine:
 - a. A preferred control switch other than the foot switch provided (see Foot Pedal Switch Installation).
 - b. One-8 (1/2" SAE JIC type) adapter to tap into base machine reservoir or return line.
 - c. One-8 (1/2" SAE) hydraulic line plumbed from the base machine's hydraulic return to the end of the boom (if the shear is mounted in place of the stick) or the stick if the shear is mounted in place of the bucket.
 - d. One 15 amp circuit breaker or fuse.

ELECTRICAL INSTALLATION INTERNAL ROTATION CONTROL SYSTEM

if equipped

LaBounty provides a three-position foot switch with the Internal Rotation Control System. Alternative types of switches may be used in place of the provided foot switch, if preferred. Contact your LaBounty dealer for information on operating the control valve. Any of the following can be used:

- a. Joystick handle equipped with a single pole/double throw momentary three-position rocker switch;
- b. Two joystick handles each equipped with a single pole/single throw momentary rocker switch or push button switch;
- c. a single pole/double throw three-position momentary toggle switch mounted to the control lever with a fabricated bracket.

INSTALLATION

1. Place the foot switch or other preferred control switch inside the cab in a convenient location for operating.
2. Route the electrical cord with the plug up the boom (and stick if the shear replaces the bucket). Secure the cord to an existing hydraulic line using tie straps. Attach the green wire of this cord to the base machine chassis to ground the system.
3. Run a 14-gauge wire from the base machine's DC voltage power supply and connect it to a 15-amp circuit breaker fuse. The power source should be accessory side or a similar source that provides voltage only when the starter key switch is in the "ON" position, and should have a 5-amp minimum rating.
4. Connect a 14-gauge wire from the circuit breaker or fuse to the red wire of the electrical cord running up the boom to the electrical plug. Connect another 14-gauge wire from the circuit breaker or fuse to this red wire of the electrical cord coming from the foot switch. The red wire from the electrical plug and the red wire from the foot switch can be connected.
5. Connect the black wire from the boom cord to the black wire from the foot switch cord. Connect the white wires in the same way. The green wire from the foot switch cord will not be used.

CAUTION

To prevent electrical shock, short, or accidental start-up, do not connect to the power source until the entire system is installed.

NOTICE

Make sure to complete all installation procedures described in this section before starting the machine. Operating the shear before proper installation is complete may cause damage to the base machine.

ELECTRICAL SCHEMATIC INTERNAL ROTATION CONTROL SYSTEM

if equipped

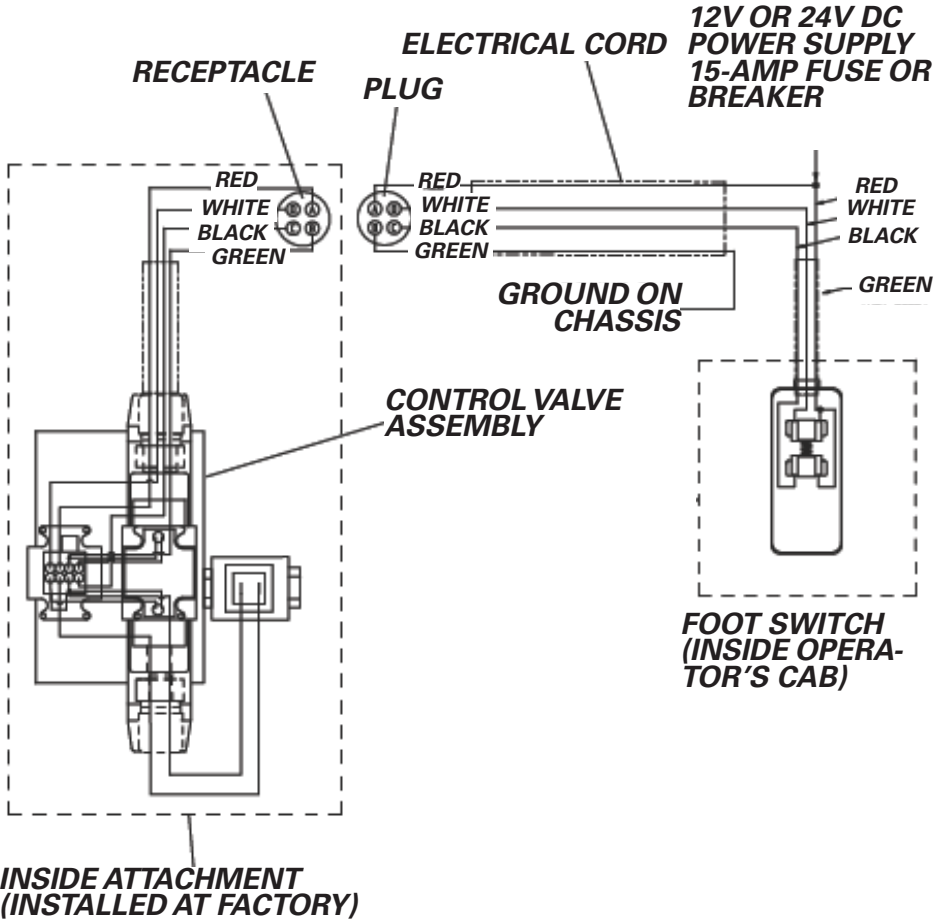

FIGURE 3-5

MSD SABER SERIES SHEARS

HYDRAULIC RETURN LINE INSTALLATION INSTRUCTIONS INTERNAL ROTATION CONTROL SYSTEM

1. Always relieve all hydraulic pressure of the base machine by working the controls in all directions with the engine off before beginning work on any hydraulic component. See **Figure 3-6**.
2. Shut off the base machine and check the hydraulic system pressure. It should be zero PSI.
3. Hydraulic oil becomes hot during operation. **DO NOT** let hydraulic oil get in contact with the skin as it will cause severe burns.

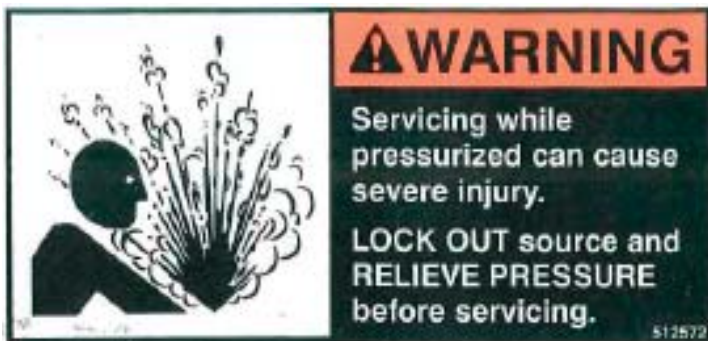

FIGURE 3-6

4. Whenever hydraulic lines are disconnected, hoses must be capped and ports must be plugged to prevent contamination of the hydraulic system.
5. Install a 1/2" diameter hydraulic line (customer supplied) from the attachment's return fitting, located in the right hand hydraulic manifold, to the base machine's hydraulic reservoir or return line. Secure the line properly to the excavator boom and stick.

WARNING

Escaping fluid under pressure can penetrate the skin causing serious injury. Relieve pressure before disconnecting hydraulic lines. Tighten all connections before applying pressure. Use a piece of cardboard to search for leaks. If ANY fluid is injected into the skin, seek immediate medical assistance.

HYDRAULIC SCHEMATIC INTERNAL ROTATION CONTROL SYSTEM

Check your internal rotation control system regularly.

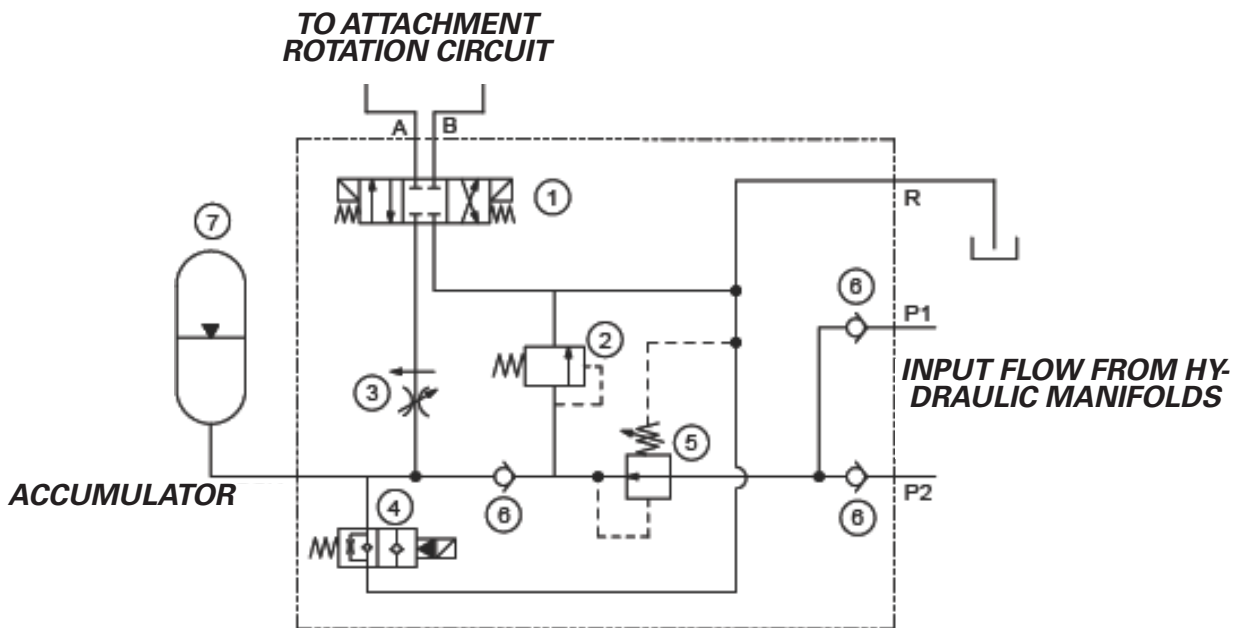

FIGURE 3-7

1. DIRECTIONAL CONTROL VALVE
2. RELIEF VALVE - SET AT 3000 PSI (200 BAR)
3. FLOW CONTROL
4. UNLOADING VALVE
5. PRESSURE REDUCING VALVE - SET AT 2500 PSI (170 BAR)
6. CHECK VALVE
7. ACCUMULATOR - SET GAS CHARGE AT 1100 PSI (76 BAR)

SECTION 4 OPERATION

Before You Start	4-2
First Things First	4-2
Safety Devices You'll Need	4-2
General Rules for Safe Operation	4-3
Mobile Shear Controls	4-4
Operating the Rotator	4-6
Backdriving the Rotator	4-6
Operating the Internal Rotation Control System	4-6
Recharging the Accumulator with Fluid	4-6
Speed Valve Operating Characteristics	4-7
Getting the Feel of the Attachment	4-7

MSD SABER SERIES SHEARS

BEFORE YOU START

KNOW YOUR SAFETY PROGRAM

1. Read and understand the safety section of this manual and the base machine manual.
2. Know the employer's safety rules for your job. Consult your foreman for specific instructions and safety equipment required.
3. Learn the traffic rules at the work site.
4. Know the hand signals used on the job and who is responsible for signaling. Take signals from only ONE person.



KNOW YOUR EQUIPMENT

- Learn the location and function of all controls. Test all controls to ensure proper operation. If any malfunctions are found, shut the machine down and report the malfunction for repair.
- Be familiar with the safety devices on the machine, indicators, warning devices and caution instructions. They will alert you to conditions that may make it hazardous to continue operating.
- Wear proper protective clothing including hard hat, safety shoes, ear protectors, reflective clothing, safety goggles and work gloves. Loose clothing can get caught in machinery and cause injury. Wrist watches, rings and other accessories can be dangerous, as well.
- Know the clearances in the work area.

FIRST THINGS FIRST

1. Ensure all safe viewing distance decals are installed and legible; contact LaBounty for replacements as required.
2. Have a **DAILY** Safety Dialog with all those with whom you work. Inform them of any out-of-the-ordinary work that may be planned for the day. Remind them of the safe working distance.
3. Clear the area; inspect. **ALWAYS** look out for others. In any work area, people constitute a serious safety hazard. Before operating, walk completely around the machine to be sure there are no workers next to, under or on it. Warn nearby workers that you are starting up; **DO NOT** start up until they are out of danger.
4. Each day before starting, visually inspect the machine by walking around it entirely; check the location of cables, gas lines, and water mains before any operations. Make sure work site footing has sufficient strength to firmly support the machine. When working close to an excavation, position machine with the propel motors at the rear.
5. Once started, keep bystanders clear, especially before moving the boom, swinging the upper structure, or traveling. **ALWAYS** be alert for bystanders in or near the operating area.

SAFETY DEVICES YOU'LL NEED

- Seat belts
- Canopies
- Falling Objects Protective Structures (FOPS)
- Shields and guards
- Safety decals
- Visual or audible warning devices
- Flags and flares
- Barricades
- Signs and other markings
- Warning lights

GENERAL RULES FOR SAFE OPERATION

1. Read the Operator's Manual for the base machine on which the shear is mounted.
2. **KNOW** the capacity of the excavator and its attachments. **DO NOT** overload the machine or serious injury could result. The attachment may have altered the base machine's lift capabilities.
3. It is required that a Falling Objects Protection Structure be installed surrounding the excavator cab for all material handling applications.
4. The shear is for processing materials. **DO NOT** use the attachment for unapproved purposes or warranty may be voided.
5. **DO NOT continuously** process oversized materials by forcing them into the shear throat with the downward force of the excavator. This practice is detrimental to the life of the shear and is strongly discouraged.
6. If the shear stalls during processing, scale back the amount of material being processed at one time. Continuously overloading the shear and cycling the excavator to full system pressure can cause overheating and have adverse effects on the shear and the excavator hydraulic system.
7. Whenever possible, cycle the shear cylinder completely during processing. Fully opening and closing the shear allows more hydraulic fluid to circulate through the system to help prevent overheating.
8. Inspect and lubricate the shear daily. Tighten any loose bolts or fittings to the proper torque as specified in this manual.
9. Maintain a safe distance and avoid contact between the excavator and the shear or any material held by the shear jaws.
10. **NEVER** leave the shear suspended or pass it over people, occupied vehicles, or buildings.
11. When working in confined spaces, keep a watchful eye on exposed parts, such as cylinder rods and hoses, to avoid damage.
12. Maintain at least 15 feet (5 meters) between the shear and any nearby power lines.
13. **ALWAYS** lower the shear to the ground and turn the base machine off when leaving the machine unattended.
14. **DO NOT** close the shear on a structure and reverse the excavator in an attempt to pull down material. This is not only dangerous, but will likely damage the excavator and shear.
15. Avoid collision of the boom or shear, especially when working with limited visibility or inside buildings. Know the height and reach of the shear during operation, transport, and when swinging the excavator.
16. Use machine swing for positioning only. **DO NOT** use the shear as a jack hammer or wrecking ball.
17. Avoid contact between boom arm or shear stick and overhead obstacles when you operate, move, or haul the machine.
18. **DO NOT** alter factory preset hydraulics of the shear or vary from the excavator manufacturer specifications. This may void the warranty.
19. **DO NOT** shear high tensile steel such as railroad rail, spring steel, axles and some types of wire as blade, Saber Tip, and/or upper damage will result. This type of material breaks when processed and can become a projectile which could cause injury or death.
20. To prevent bending the upper shear, **DO NOT** attempt to shear material stuck through the lower jaw.
21. Before attempting to shear thin material, make sure that the shear blades are sharp and properly adjusted. Otherwise, such material may become jammed in the shear blades.
22. The lifting lugs are to be used for shipping and installation. They are not for use in cable-hung applications.
23. The shear rotation function is for positioning only. **DO NOT** use it for bending, breaking or prying.
24. **DO NOT** use the force of the excavator to force the shear into a pile.
25. **DO NOT** apply excavator force or weight at either end of the upper shear in an attempt to un-jam the shear or to cut materials that are too large for the shear.

MSD SABER SERIES SHEARS

MOBILE SHEAR CONTROLS

There are four basic movements of a mobile shear plus one for rotating the shear if it is equipped with the rotation option. Mobile shear controls will vary slightly depending on the type of base machine and whether the shear is mounted as a second or third member. The shear open/close and rotation systems are customized to each machine. Review the shear operations with an authorized dealer or the installation technician before operating. The functions for a typical shear third-member installation are illustrated below (see **Figure 4-1**). and on page 4-5 (second-member installation).

⚠ WARNING

Determine the control for each movement of the shear before attempting to operate. Practice the machine movements as described in *Getting the Feel of the Shear* instructions in this section.

THIRD- MEMBER INSTALLATION

Shear replaces bucket

FIGURE 4-1

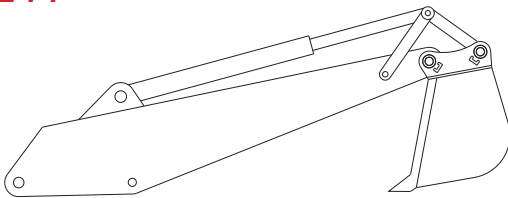

Bucket CURL = Shear IN

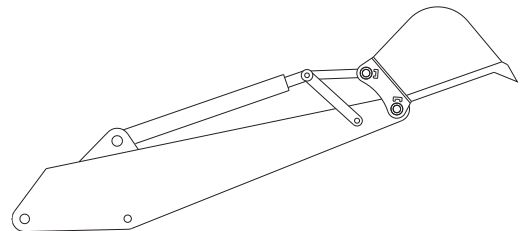

Bucket DUMP = Shear OUT

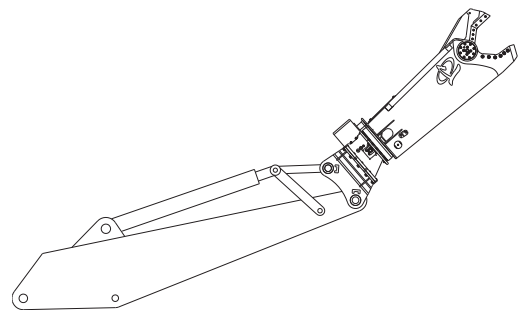
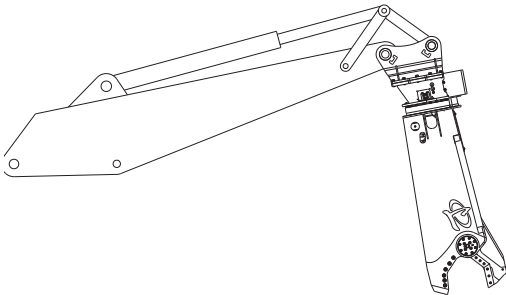

MOBILE SHEAR CONTROLS (CONTINUED)

SECOND MEMBER INSTALLATION

Shear replaces stick

FIGURE 4-2

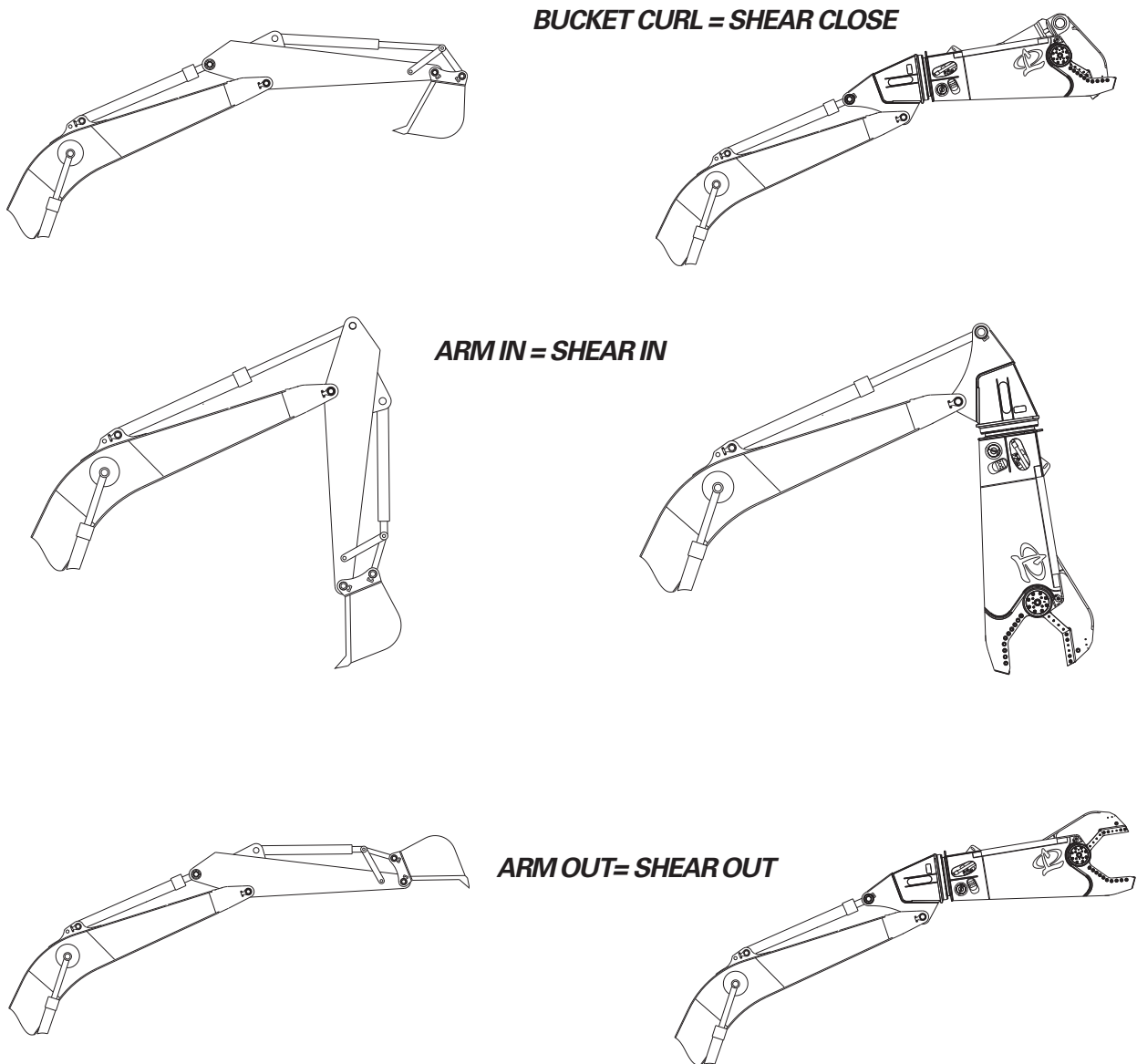

MSD SABER SERIES SHEARS

OPERATING THE ROTATOR

if equipped

The rotator gives the shear 360° of continuous rotation in both directions for easy, accurate processing at all angles. The rotator requires special attention when operating the shear. The rotator is to be used only to position the shear, not as a means of bending, twisting, or breaking material.

⚠ CAUTION

DO NOT use the shear rotator for any other purpose except to position the shear for a cut. Using the rotator for any other purpose, such as bending or twisting material, will damage the rotation components and may void the shear warranty.

BACKDRIVING THE ROTATOR

Backdriving occurs when an excessive, off-center force is applied to the shear. Examples of this are closing the jaws on a rigid member without the jaws being square to the member or handling a heavy load off-center in the jaws. **Backdriving puts undue stress on the rotation system and, if done continually, can lead to rotation component problems.** Follow the tips below to minimize backdriving as much as possible.

1. When handling a load in the jaws, try to grip it as close to its center of gravity as possible
2. When processing a long member that is suspended, make several shorter cuts rather than one long cut where the member can come loose and backdrive the rotator.
3. When processing any rigid member, use the rotator to square the jaws to the cut. If the jaws are not square, the rotator will backdrive to adjust to the cut.

OPERATING THE INTERNAL ROTATION CONTROL SYSTEM

if equipped

The foot switch installed in the operator's cab is used to operate the Internal Rotation Control System, assuming an alternative customer provided switch is not used. The foot switch provided by LaBounty has three positions—center, front (toe), and back (heel). The switch will automatically move to the neutral center position when it is not being used. No rotation occurs in this position. The other two positions will cause the shear to rotate. One position will cause clockwise rotation and the other will cause counterclockwise rotation.

RECHARGING THE ACCUMULATOR WITH FLUID

When using the Internal Rotation Control System, the shear will typically rotate between 100° and 270° each time the accumulator is charged with fluid. When the accumulator runs out of fluid charge, it is necessary to recharge the system before rotating the shear again. To recharge the system, simply open or close the shear. The system draws hydraulic fluid from the jaw circuit when the jaws are operated.

NOTICE

- *The amount of rotation your shear will achieve per fluid charge depends on the shear model.*
- *Continuous rotation can be achieved by cracking an excavator function that charges the accumulator.*
- *The accumulator needs to be charged with fluid when the base machine is first started up. The unloading valve is designed to drain to the accumulator whenever the base machine is shut off.*

SPEED VALVE OPERATING CHARACTERISTICS

The function of the speed valve is to increase the shear closing speed (cylinder extend function) when the shear is not under a load, thereby reducing cycle times and increasing efficiency. The speed valve directs return flow from the rod side of the cylinder to the bore side as the cylinder extends. This function occurs only when the cylinder is extending in a “low to medium load” condition, which occurs as the upper shear jaw is moving toward the material to be cut. As the shear jaws close down on the material to be cut, the cylinder meets resistance and requires more operating pressure. The pilot valve on the speed valve senses this increased pressure and shifts the valve spool out of the speed mode. The rod side fluid is now directed back to the base machine reservoir and full system operating pressure can now be directed to the bore side of the cylinder, allowing the shear to cut the material with maximum force.

GETTING THE FEEL OF THE SHEAR

Before starting the first job with a new machine, it is suggested that the operator find an open spot on firm, level ground that’s free of obstructions such as trees, buildings, people, and other equipment. Move the machine to this area, and spend some time just getting to know the “operating feel” of the machine and the shear. The machine is extremely powerful. Be concerned about safety when preparing to operate the new machine. Ensure safe operation by inspecting the machine as stated in **Getting Started Safely**. Read the **Getting Started Safely** section of this manual and understand it.

The control levers should be moved in a gradual, deliberate way rather than with jerky, abrupt movements. Jerky operation can cause damage and early wear to various parts on the machine, and can also overheat the hydraulic system. For example, as each control lever is moved forward or backward from the center, or neutral position, the oil flows to the cylinder or motor controlling a function. The component (boom, attachment, etc.) starts to move. The component moves faster as the control lever is moved further forward or backward. Holding the lever in the forward or backward position will hold that movement at a given rate of speed. To slow the movement down, gradually move the lever toward the neutral position. Movement is stopped at the neutral position. The position is maintained until the control lever is moved again. Feathering the controls is a technique that will increase output and make operating the shear easier. When starting any motion of the machine, move the control slightly from neutral until it starts to move, then smoothly move the control to increase motion to desired speed. Do the same when stopping a motion.

SECTION 5 MAINTENANCE

Scheduled Maintenance	5-2
Recommended Spare Parts List	5-3
Maintenance Safety Procedures	5-4
General Rules for Maintenance	5-4
8-Hour Service Recommended	5-5
80-Hour Service Recommended	5-5
2000-Hour Service Recommended	5-5
8-Hour Inspection Checklist	5-6
80-Hour Inspection Checklist	5-7
8-Hour Inspection Rotator Checklist	5-8
Lubrication	5-9
Bolt Torque Guidelines	5-10
Metric Capscrew Size Guide	5-10
Torque Values for Metric Fasteners	5-11
Slide Screw Maintenance	5-12
Blade Removal	5-14
Blade Bolt Torque Specifications	5-15
Torque Values for Blade Bolts	5-15
Guide Blade Shimming and Rotation	5-16
Cutting Blade Rotation Procedure	5-17
Weld-in Tip Cutting Blade Rotation Procedure	5-21
Cutting Blade Shimming	5-22
General Guidelines for Build-up and Hardsurfacing	5-23
Build-up Recommendations	5-24
Hardsurfacing Recommendations	5-24
Critical Wear Areas	5-26
Upper Shear Build-up and Hardsurfacing	5-27
Weld-in Tip Maintenance	5-28
Weld-in Tip Replacement	5-30
Front Wear Plate Replacement	5-32
Lower Wear Plate Replacement	5-33
Lower Shear Build-up and Hardsurfacing	5-34
Hydraulic System Maintenance	5-37
Flange Type Hose Fittings	5-37
Torque Values for Four-Bolt Flange Fittings	5-38
Applying Split Flange Clamps	5-39
Cylinder Gap Check	5-40
Hydraulic Schematic- Standard Rotating Shears	5-41
Hydraulic Schematic- Standard Non-rotating Shears	5-41
Speed Valve Adjustment	5-42
Decal Maintenance	5-54

MSD SABER SERIES SHEARS

SERVICE AND MAINTENANCE PROCEDURES	8 HOURS	80 HOURS	2,000 HOURS
Visually inspect shear for damage	•		
Inspect all safety decals	•		
Inspect cab protection on excavator	•		
Confirm all excavator warning systems are operational	•		
Lubricate each side of main pivot group (2 each side)	•		
Lubricate end slide puck assemblies (each side)	•		
Lubricate end of front cylinder pin	•		
Lubricate end of rear cylinder pin	•		
Lubricate boom pivot connection of mounting bracket	•		
Lubricate cylinder connection of mounting bracket	•		
Inspect pinheads and pinkeepers	•		
Inspect all bolts for looseness or damage	•		
Check slide puck /back wear plate gap; refer to manual if gap exceeds .010" (.25mm)	•		
Check guide blade/Saber Tip gap; refer to manual if gap exceeds .030" (.75mm)	•		
Check cutting blade gap; refer to manual if gap exceeds .030" (.75mm)	•		
Inspect Saber Tip; ensure it fits squarely in upper jaw	•		
Inspect cross blade for any looseness or damage	•		
Inspect hoses for wear and potential failure	•		
Inspect cylinder for leaks	•		
If rotator equipped:	•		
Grease turntable bearing	•		
Inspect rotation hoses (and hose connections) for wear, leaks, potential failure	•		
Check rotation assembly bolts	•		
Inspect all bolts connecting turntable bearing to upper head and shear; replace as needed		•	
Rotate or replace cutting blades, Saber Tip, cross and guide blades		•	
Check slide screw wear; replace if necessary		•	
Inspect upper shear: check build up and hardsurface around blade edges; build up if needed		•	
Replace wear plates on lower shear if necessary		•	
Check split flanges and fitting for looseness; tighten if necessary		•	
Inspect and maintain the lower secondary blade buffer or build-up strip		•	
Replace shear cylinder seals (including Nylock lock ring)			•
Replace swivel manifold seals (if equipped)			•

RECOMMENDED SPARE PARTS LIST

The following is a description of the parts Stanley LaBounty recommends to have on hand for these benefits.

- 1.** Less downtime for lack of a part.
- 2.** Original equipment manufacturer parts are inspected to Stanley LaBounty standards for proper fit and function.
- 3.** Eliminate the possibility of a part being unavailable for immediate delivery.
- 4.** Eliminate overnight air freight costs.
- 5.** The accessibility of replacement parts assures the proper shear maintenance will be followed and therefore increase the efficiency of the shear.

UPPER AND LOWER JAWS OF THE SHEAR:

BASIC ASSEMBLY

Cutting blades
Guide blade
All bolts and washers used to fasten blades
Blade shims for lower shear blades (not supplied with new blades)
Complete blade kits

UPPER SHEAR

Saber Tip™
One extra upper secondary blade
All bolts & washers used to fasten tip

HYDRAULIC ASSEMBLY

All hydraulic hoses
O-ring face seal adapters (ORS)

CYLINDER ASSEMBLY

Cylinder seal kit (ordered by cylinder part number and serial number)

ROTATION ASSEMBLY if equipped

Crossover relief or motion control valve (one is applicable to each rotation assembly)

MANIFOLD ASSEMBLY if equipped

O-ring seals
Crown seals

STANLEY LABOUNTY BLADE MAINTENANCE TOOL KIT

P/N 184238.

NOTICE

Do not substitute parts unless you know they are the same in ALL characteristics. Your warranty could be compromised by using parts other than original LaBounty parts.

NOTICE

Refer to the shear parts catalog for specific part numbers. Be sure to reference the attachment serial number.

MSD SABER SERIES SHEARS

MAINTENANCE SAFETY PROCEDURES



During maintenance of the shear, it is imperative that the excavator is turned OFF to prevent injury.

- Inspect the shear daily. **DO NOT** operate a poorly maintained or damaged shear or major structural damage could result.
- **ALWAYS** lower the shear to the ground before leaving the cab. If it is necessary to work on a shear off the ground, securely support the base machine and shear. **DO NOT** support the shear on cinder blocks, hollow tiles, or props that may crumble under continuous load. **DO NOT** rely on the cylinder to hold the shear in the air. If a control is moved or hydraulic pressure is otherwise released, the shear will drop. **DO NOT** work under a machine that is supported solely by a jack.
- **NEVER** operate the machine if an unsafe condition exists. Attach a “DO NOT OPERATE” tag to the machine.
- If more than one person is working on a machine, each must be familiar with the controls and aware of what the others are doing. Before working on a machine, **BE SURE TO TAG THE CONTROLS SO NO ONE ELSE WILL START IT.**
- **ALWAYS** use two people when making checks with the engine running.
- Keep hands away from moving parts. **NEVER** lubricate or work on a machine while it is moving.
- **ALWAYS** wear proper safety equipment when maintaining the shear including safety glasses with side shields, hard hat, steel toe shoes, gloves, and hearing protection.

GENERAL RULES FOR MAINTENANCE

1. Read the maintenance manual. Be sure all maintenance personnel read and understand all maintenance procedures before they attempt them.
2. Use factory approved parts. Use of parts that are not factory approved may cause damage or unnecessary downtime and may void the warranty.
3. Lubricate every four hours; follow the lubrication schedule as outlined on page 5-9.

4. Use the included Inspection Checklists during shear inspections to make sure all maintenance is complete.
5. In extremely cold temperatures, work the shear on lighter materials first before working up to heavier materials. **DO NOT** operate at temperatures below -10° F (-23°C).
6. To get maximum life from the shear blades, rotate to utilize all four edges.
7. **DO NOT** enter the pivot group of the shear without first consulting your dealer or the Stanley LaBounty Customer Service Department.
8. The machined adjustment plates behind the cutting blades in the lower shear have been custom machined for each shear. If they should come loose, be sure to replace them properly.
9. **ALWAYS** connect the welding ground cable directly to the attachment component that you are welding on. **DO NOT** allow ground current to run through the pivot group, the rotation group, or the hydraulic cylinder.
10. **DO NOT** weld guide blades, and/or the other blades, into their blade seats. The guide blade is needed for proper adjustment of the shear. **DO NOT** allow excessive gap between guide blade and Saber Tip.
11. **DO NOT** weld or hardsurface across the grain of the steel at any time. When hardsurfacing, do not exceed two passes of hardsurface rod.
12. **DO NOT** weld on the excavator boom or stick without first consulting the excavator manufacturer for proper welding procedures.
13. Rotate or replace the blades when edges have rounded to approximately ¼" (6 mm) radius or after 80 hours, whichever comes first.
14. **DO NOT** adjust the slide screws when the upper shear is in either the full-open or full-closed position. Be sure the slide screw will contact the rear wear plate when adjusting. Lubricate the slide screw assembly every eight hours of operation.
15. **DO NOT** weld on blades.
16. Torque bolted connections as prescribed in this manual.
17. **DO NOT** disconnect any hydraulic hoses or fittings without first relieving the excavator system hydraulic pressure.
18. **DO NOT** exert the weight of the excavator on the shear in order to free the upper shear if it becomes jammed. Please consult the factory.

GENERAL RULES FOR MAINTENANCE continued

19. DO NOT let hot hydraulic oil get in contact with the skin as it could cause severe burns.

20. DO NOT operate a rotating shear without a case drain line connected back to the tank or return line filter (rotating shears only), or the rotation component will be damaged. Smaller shears (MSD 1000) do not require a case drain.

8-HOUR SERVICE RECOMMENDED

Inspect the Shear: Look over the shear for damage or any clues that might indicate a potential problem. Inspect Safety Devices: Make sure all decals are installed and legible. Inspect the condition of the cab protection and make sure visual and audible warning devices are working properly. Make all repairs before using the equipment.

Grease Fittings: Lubricate according to the shear Lubrication section. Replace broken fittings.

Connecting Pins: Inspect the mounting bracket pins and shear cylinder pins for looseness or damage. Check pinheads and pin keepers.

Bolts: Check for looseness or damage. Torque if necessary according to the proper torque chart in this manual.

Slide Screws: Inspect for damage. Refer to the adjustment procedure on page 5-12. Lubricate the puck assembly and contact area.

Saber Tip/Guide Blade Gap: Inspect for damage. If gap exceeds 0.030" (0.76mm) refer to the shimming instructions in this manual.

Cutting Blade Gap: Inspect. Shimming is necessary if the gap exceeds recommendations; see page 5-17. For most applications, this gap should be maintained at 0.010" to 0.020" (0.25 to 0.50 mm). This gap may be shimmed down to 0.005" (0.13 mm) if jamming becomes a problem when processing thin materials.

Hoses, Connections, Cylinders: Inspect for leaks, wear and damage. Tighten, repair or replace.

Rotator (if equipped): Check all turntable bearing bolts for looseness or damage. Bolts may be retorqued only once and then must be replaced. Refer to the Turntable Bearing Bolt Torque Chart on page 6-3 for proper torque values. Lubricate according to instructions in this manual.

80-HOUR SERVICE RECOMMENDED

Cutting Blades: Measure blade gap, rotate blades and shim blades according to procedures in this manual.

Upper Shear: Inspect cutting blades, Saber Tip, and parent material around blade edges. Refer to manual for build-up, hardsurface or blade replacement instructions.

Lower Shear: Inspect guide blade, nose blade, and lower shear. Refer to manual for build-up, hardsurface or replacement instructions.

Rotator (If equipped): Inspect all bolts connecting the turntable bearing to the head and shear for looseness or damage. Bolts must be replaced if retorquing is necessary. Refer to the Turntable Bearing Bolt Torque Chart on page 6-3 for proper torque values.

2,000-HOUR SERVICE RECOMMENDED

Shear Cylinder Seals: It is recommended that the shear cylinder seals be replaced every 2,000 hours. Operating the shear with worn-out seals will decrease shear performance and may cause internal damage to the cylinder. Please note that cylinder seal life is highly dependent on the care taken to properly maintain the hydraulic fluid. Fluid with higher levels of contaminants and particulates will wear down cylinder seals faster than fluid that is properly filtered and changed out regularly. It is necessary to replace the cylinder seals more frequently if the shear works regularly in severe-duty applications or if the hydraulic fluid is not properly maintained.

MSD SABER SERIES SHEARS

8-HOUR INSPECTION CHECKLIST

Shear Model _____ Excavator Hour Meter _____

Shear Serial Number _____ Date _____

- _____ 1. Visually inspect shear for any damage
- _____ 2. Inspect safety devices
 - _____ a. All safety decals in place and legible- seal decal and label maintenance section
 - _____ b. All cab protection in good condition
 - _____ c. All excavator warning systems working
- _____ 3. Lubricate all points. Refer to shear lubrication in this section
 - _____ a. Each side of main pivot group (two each side)
 - _____ b. End of slide puck assemblies (each side)
 - _____ c. End of front cylinder pin
 - _____ d. End of rear cylinder pin
 - _____ e. Boom pivot connection of mounting bracket
 - _____ f. Cylinder connection of mounting bracket
- _____ 4. Inspect connecting pins and pin retaining hardware
 - _____ a. Boom pivot pin of mounting bracket
 - _____ b. Cylinder connection pin of mounting bracket
 - _____ c. Front shear cylinder pin
 - _____ d. Rear shear cylinder pin
 - _____ e. Pinheads and pinkeepers
- _____ 5. Inspect all bolts
 - _____ a. Visually inspect all bolts and replace any that are loose or damaged
- _____ 6. Check slide puck/wear plate gap
 - _____ a. Refer to manual if gap exceeds recommendations; see page 5-21
- _____ 7. Check guide blade/Saber Tip gap
 - _____ a. Refer to manual if gap exceeds recommendations; see page 5-21
- _____ 8. Check cutting blade gap
 - _____ a. Refer to manual if gap exceeds 0.030" (0.75 mm)
- _____ 9. Inspect Saber Tip
 - _____ a. Saber Tip fits squarely in upper jaw
- _____ 10. Inspect cross blade for looseness or damage
- _____ 11. Inspect Hydraulic System
 - _____ a. Inspect hoses for wear and potential failure
 - _____ b. Inspect hose connections for leaks
 - _____ c. Inspect cylinder for leaks

Inspected by: _____

80-HOUR INSPECTION CHECKLIST

Attachment Model _____ Excavator Hour Meter _____

Attachment Serial Number _____ Date _____

- _____ **1. Inspect blades**
 - _____ a. Rotate or replace upper cutting blades
 - _____ b. Rotate or replace Saber Tip, nose blade, and guide blade
 - _____ c. Measure blade gap, refer to manual for shimming procedure and tolerance range
- _____ **2. Inspect slide screw and slide screw gaps, each side**
 - _____ a. Check for slide screw wear, replace if necessary
 - _____ b. Measure slide screw gap, adjust if necessary
- _____ **3. Inspect upper shear**
 - _____ a. Build-up and hardsurface upper shear
- _____ **4. Inspect lower shear**
 - _____ a. Replace wear plates if necessary
- _____ **5. Inspect hydraulic components**
 - _____ a. Check split flanges and fittings for looseness, tighten if necessary
 - _____ b. Check hoses for wear or cracking

If Rotator equipped:

- _____ **1. Inspect all bolts connecting the turntable bearing to the upper head and shear**
 - _____ a. Replace bolts if retorque is necessary

Inspected by: _____

NOTICE

IMPORTANT

It is recommended that the shear cylinder and swivel seals be replaced every 2,000 hours. Operating the shear with worn-out seals will decrease shear performance and may cause internal damage to the cylinder. It is recommended that this work be performed by an authorized Stanley LaBounty Dealer. The Nylock lock ring must be replaced each time a new seal kit is installed.

It is recommended that the cylinder shear seals be replaced by an authorized Stanley LaBounty dealer. The Nylock lock ring must be replaced each time the cylinder seals are installed.

MSD SABER SERIES SHEARS

8-HOUR INSPECTION ROTATOR CHECKLIST

Shear Model _____ Excavator Hour Meter _____

Shear Serial Number _____ Date _____

- _____ 1. Visually check all turntable bearing bolts and replace any that are loose or damaged
- _____ 2. Grease the turntable bearing- refer to the Rotator Maintenance section for instructions
- _____ 3. Inspect the rotation hydraulics system
 - _____ a. Inspect rotation hoses for wear and potential failure
 - _____ b. Inspect rotation hose connections for leaks
- _____ 4. Visually check all rotation assembly bolts

Inspected by: _____

LUBRICATION

Regular lubrication of the attachment is absolutely vital to proper operation and long life of the attachment. The speed valve feature accelerates the shear cycle time and allows the shear to open and close more often throughout the day. This makes it necessary to lubricate the shear more frequently than was required with older models. Use premium grease No. 2EP or equivalent and lubricate all points every 4 hours of operation. Grease fitting locations are indicated in Figure 5-1 and by the "GREASE" decals on the attachment. Grease all fittings at the main pivot group with the shear jaws open AND with the shear jaws closed to evenly distribute the grease throughout the pivot group.

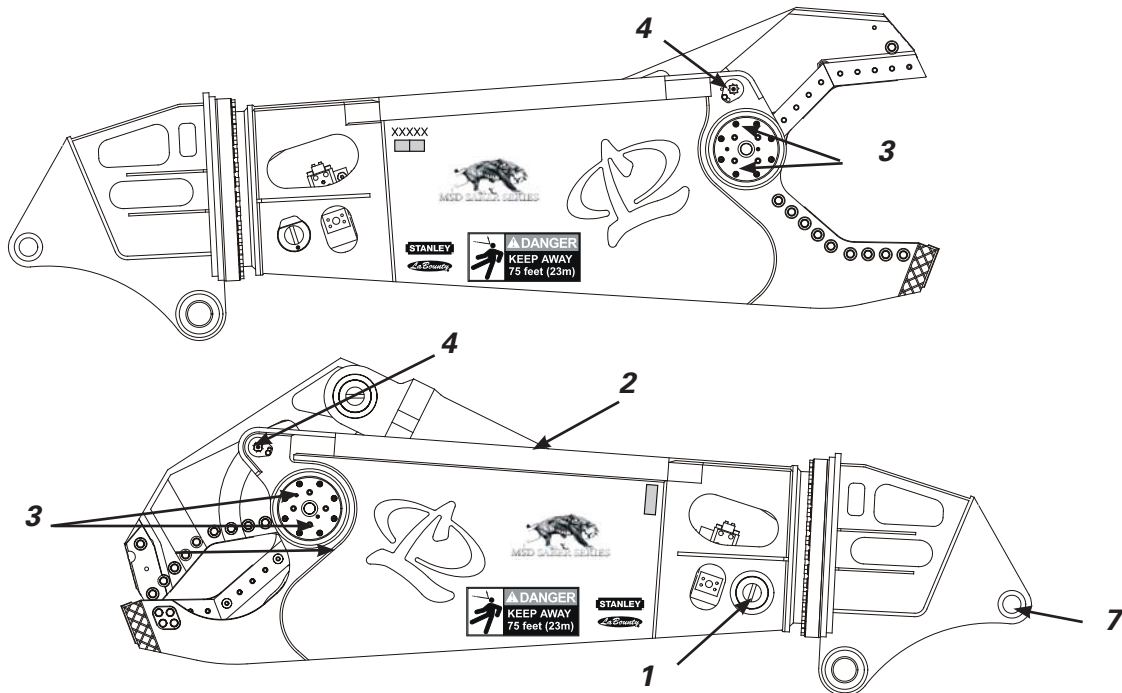

FIGURE 5-1

ROTATOR DESIGNS VARY BY MODEL. LOOK FOR GREASE DECALS WHEN LUBRICATING THE ATTACHMENT.

LOCATION ON ATTACHMENT

1. Rear cylinder connection
2. Front cylinder connection
3. Main jaw pivot (2 zerks each side)
 - a. Jaw Open
 - b. Jaw closed
4. Slide screw
 - a. Left side
 - b. Right side
5. Turntable bearing (rotators only)

NUMBER OF SHOTS

- | |
|--------------------------|
| 6 |
| 6 |
| 6 |
| 6 |
| 6 |
| 6 at each grease fitting |
| 6 at each grease fitting |
| 6 at each grease fitting |

LOCATION ON BRACKET

6. Boom pivot connection- consult excavator maintenance manual
7. Linkage connection (3rd member mount) or cylinder pivot connection (2nd member mount)

MSD SABER SERIES SHEARS

BOLT TORQUE GUIDELINES

Proper bolt installation is critical to ensure the safe and efficient operation of the shear. Carefully follow the steps below to properly install bolts.

1. Always replace bolts and nuts with the same size and class of fastener. Replacement fasteners can be ordered from the Stanley LaBounty Parts Department to ensure the correct part is used (refer to **Figure 5-2**). Unless otherwise specified, use class 10.9 metric hex head capscrews, class 10.9 metric flat head capscrews, and class 12.9 metric socket head capscrews.
2. Make sure bolts, nuts and bolt holes are free of dirt, oil, grease and other contaminants.
3. If necessary, use the Capscrew Size Guide on this page to help determine the size of the bolt being installed.
4. The torque values in this manual are for use with non-plated fasteners with clean, dry threads. These values are suitable for use with or without thread adhesives, such as Loctite products. Please note that proper torque values may vary depending on the specific area of the shear.

METRIC CAPSCREW SIZE GUIDE

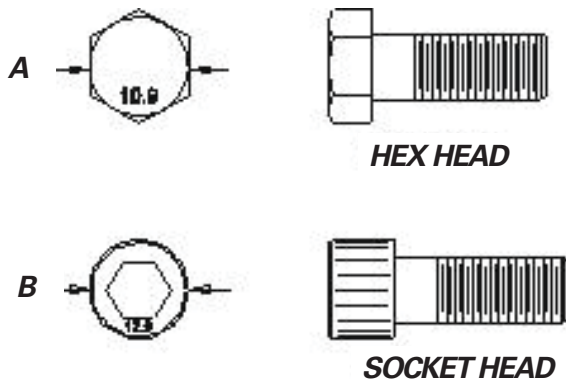

FIGURE 5-2

CAP-SCREW SIZE	A HEX HEAD	B SOCKET HEAD
M10	0.63" (16mm)	0.63" (16mm)
M12	0.71" (18mm)	0.71" (18mm)
M14	0.83" (21mm)	0.83" (21mm)
M16	0.94" (24mm)	0.94" (24mm)
M20	1.18" (30mm)	1.18" (30mm)
M24	1.42" (36mm)	1.42" (36mm)
M30	1.81" (46mm)	1.77" (45mm)

⚠ DANGER

Always replace bolts and nuts with the same size and class of fastener. Inferior fasteners can fail and cause injury or death and damage to the equipment.

TORQUE VALUES FOR METRIC FASTENERS

IMPORTANT

Please note that some parts of the shear require special torque values. These parts are listed below with the page number where the proper torque values for that area can be found. They include:

- | | |
|---------------------------------------------------------|--------------------|
| • Blade Bolts | Page 5-15 |
| • Hydraulic Connection Bolts (split flange connections) | Page 5-40 |
| • Speed Valve Bolts | Page 5-44-55, 8-26 |
| • Turntable Bearing Bolts | Page 6-3, 8-26 |
| • Rotation Assembly Bolts | Page 6-3, 8-26 |
| • End Cap Bolts | Page 8-26 |
| • SAE Straight Thread Port Hex Head Bolts | Page 8-25 |
| • Nation Pipe Thread (NPT) | Page 8-26 |

For all other bolts used in the LaBounty shear, use the Generic Torque Table, below.

CLASS 10.9			CLASS 12.9	
SIZE	FT-LBS	N-M	FT-LBS	N-M
M10	41	55	49	67
M12	71	96	85	116
M16	173	235	207	281
M20	335	454	403	547
M24	579	785	693	939
M30	1164	1579	1391	1887

WARNING

Always replace bolts and nuts with the same size and class of fastener. Inferior fasteners can fail and cause injury or death and damage to the equipment.

NOTICE

It is preferred to apply torque to the nut rather than the bolt head wherever possible.

MSD SABER SERIES SHEARS

SLIDE SCREW MAINTENANCE

Maintenance of the slide screw area is very important for keeping the cutting blades in line and for proper operation of the shear. This critical area should be inspected and adjusted every 80 hours. Use the following instructions to maintain and adjust the slide screw.

1. See **Figure 5-3**. To check and/or replace the slide screw, remove the bolts and lock plate (see **Figure 5-5**, page 5-13). Use a crescent wrench on the square end of the slide screw and turn it clockwise to adjust, counterclockwise to remove.
2. Look at the face of the slide screw to determine if there are still grease grooves (see **Figure 5-4**). If the grease grooves are worn away, it will be necessary to replace the slide screw. If the slide screw needs to be replaced, continue on with step 3.
3. To remove the slide screw, turn counterclockwise and back it completely out. To adjust the slide screws, cycle the upper jaw until the slide screw is centered on the wear plate. Clean the inside threads, if necessary, and thread in the new slide screw until it just makes contact with the wear plate (both sides). Re-install the lock plate and lock bolts, and lock the adjusted slide screw into position.
4. Apply grease to the entire assembly through the grease fitting in the slide screw. Also, apply a layer of grease to the rear wear plates on the upper shear with a brush or grease gun. Do not apply grease by hand!
5. It is recommended that the slide screws be completely removed every 80 hours of operation, the threads (both internal and external) be cleaned, and then coated with 2-EP Lithium grease. Failure to do so will result in the slide puck jamming and becoming ineffective.

SLIDE SCREW

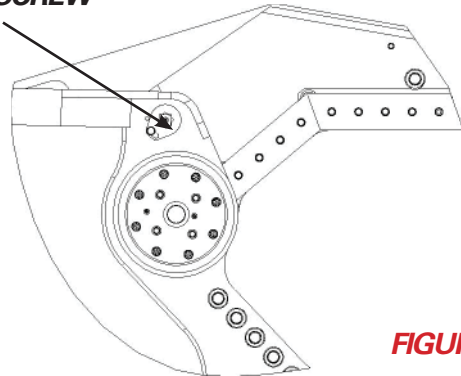

FIGURE 5-3

SQUARE END

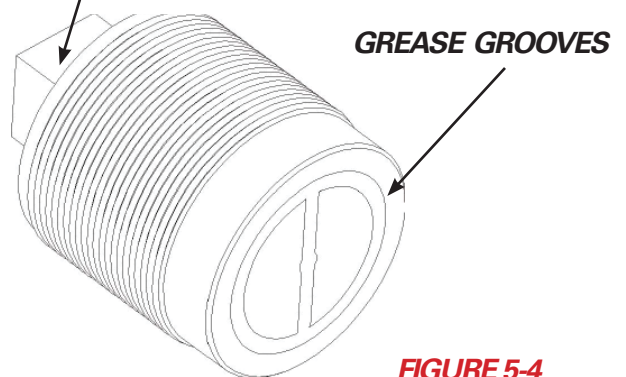

FIGURE 5-4

⚠ DANGER

DO NOT cycle or move the shear while unthreading the slide screw by hand. This will result in severe injury.

⚠ WARNING

Keep clear when the shear is in motion. Avoid pinch points, such as the upper shear or the shear cylinder, or severe injury could result.

SLIDE SCREW MAINTENANCE continued

NOTICE

- Some models (2500) have a spacer beneath the lock plate.
- MSD 1000/1500 and 1000/1500R do not have slide screws on the right (cutting blade) side.

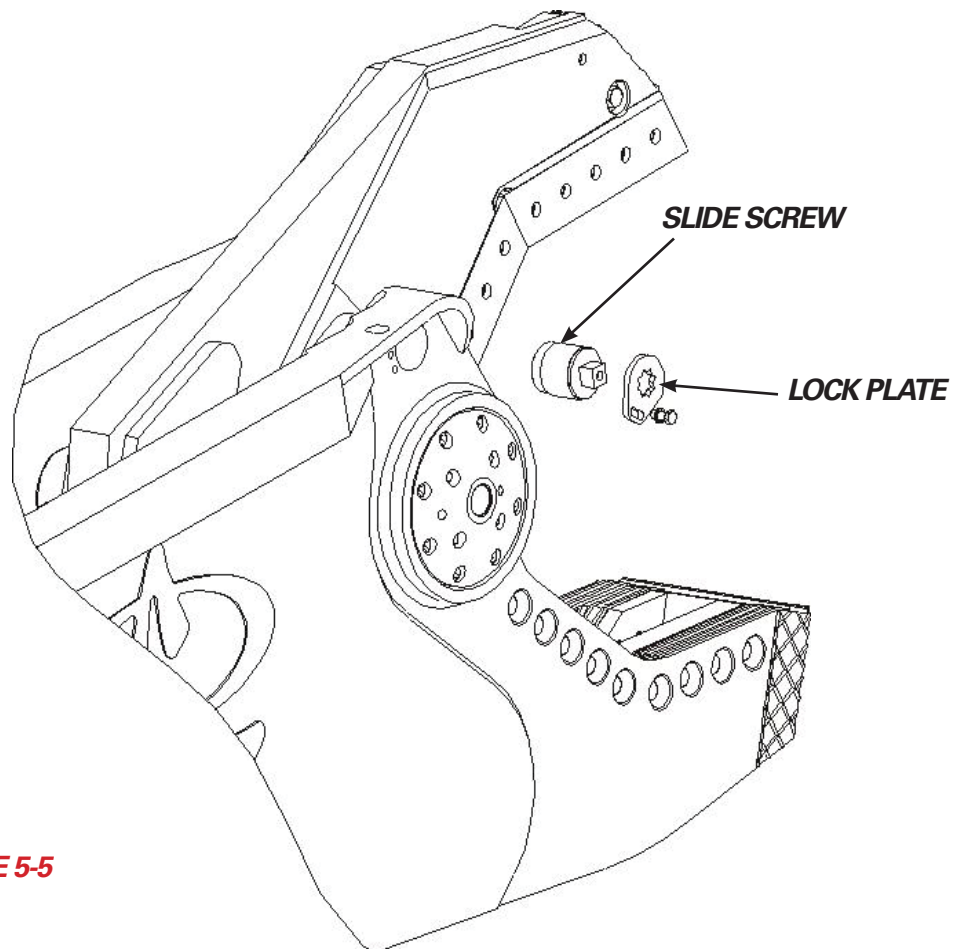

FIGURE 5-5

MSD SABER SERIES SHEARS

BLADE REMOVAL

Removing and handling shear blades can be hazardous if done incorrectly. To ensure your safety and to prevent damaging the shear, please read the following warnings and instructions when removing a blade from its seat.

CAUTION

To prevent injury, wear safety equipment at all times when maintaining the attachment. Safety equipment includes eye protection, hard hat, steel toe shoes, work gloves and hearing protection.

WARNING

Make sure the blade is well supported before removing the blade bolts. When the bolts are removed, the blade may drop and cause severe injury.

1. Loosen all blade bolts but leave them partially installed and threaded into the blade.
2. The blades may come loose from their seats without much effort. If the blades are loose, make sure they are well supported before removing the blade bolts.
3. If the blades are not loose, tap on the blade face with a soft-faced mallet to loosen the bond between the blade and seat. Use a pry bar between the top of the blade and the blade seat to loosen the blade.

WARNING

Never strike against any blade with a hardened steel tool of any kind. The blade may chip and cause severe injury.

4. If the blade is still jammed in its seat, place a wood block or similar object against the head of one of the blade bolts and strike with a mallet (see **Figure 5-6**). The bolt being struck should be within 1/2" (13 mm) of being fully threaded into the blade to prevent thread damage.

5. If you are unable to dislodge the blades using these methods, please contact your Stanley LaBounty dealer for further assistance. Also note that blade replacement kits are available. For best service, please have the serial number of your shear on hand when calling for blade replacement kits.

NOTICE

Do not strike directly on the blade bolts with a hammer or other hard object. This may cause damage to the blade threads.

NOTICE

Full blade kits are available by calling Stanley LaBounty Customer Service at 800-522-5059. For best service, please have the shear serial number on hand when calling.

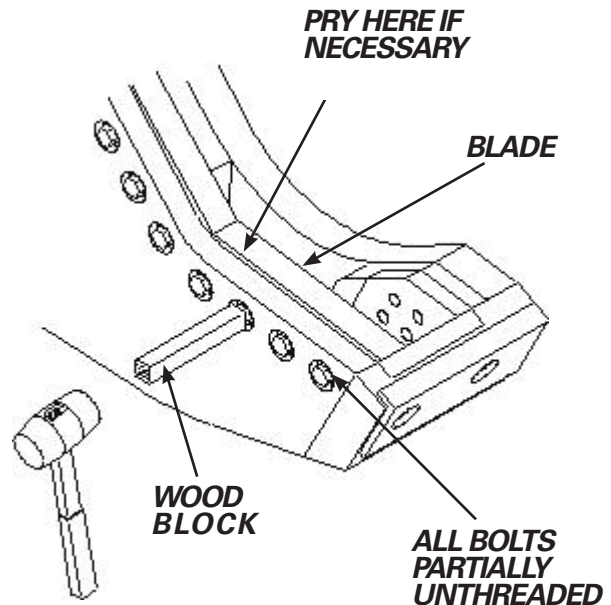

FIGURE 5-6

BLADE BOLT TORQUE SPECIFICATIONS

Proper torque of the LaBounty shear blade bolts is a crucial factor in extending the life of the shear and blade components. Maintaining the proper torque according to the specifications in this manual will help prevent loosening of blades and possible damage to the blade seats.

LaBounty shear blades can be rotated to utilize all four blade edges (see **Figure 5-7** for the components of a typical blade replacement kit). Blade bolts and washers can typically be used for the life of the accompanying blade set. Due to the critical nature of these fasteners, Stanley LaBounty requires that blade fasteners (bolts and washers) be replaced with each set of new blades.

When using existing blade fasteners during blade rotations, always inspect the hardware for any imperfections or damage and replace as necessary. If a bolt has become elongated or a washer has spun, it will be difficult or impossible to achieve proper torque to secure the blade in the seat.

Proper torque values for blade bolts are listed below. These values should only be used for blade bolts.

TORQUE VALUES FOR BLADE BOLTS

CLASS 10.9

SIZE	FT-LBS	N-M
M20	500	678
M24	900	1220
M30	1200	1627

ASSEMBLY PROCEDURE

Your new Saber shear has a raised area on the Saber Tip™ that fits into the Secondary Blade of the upper jaw. This helps provide uniform support and loading of blade seats when piercing items that do not extend totally across the piercing tip.

NOTICE

Earlier model blades have a counter-bore and removable dowels to do the same function as the updated four-bolt tip design.

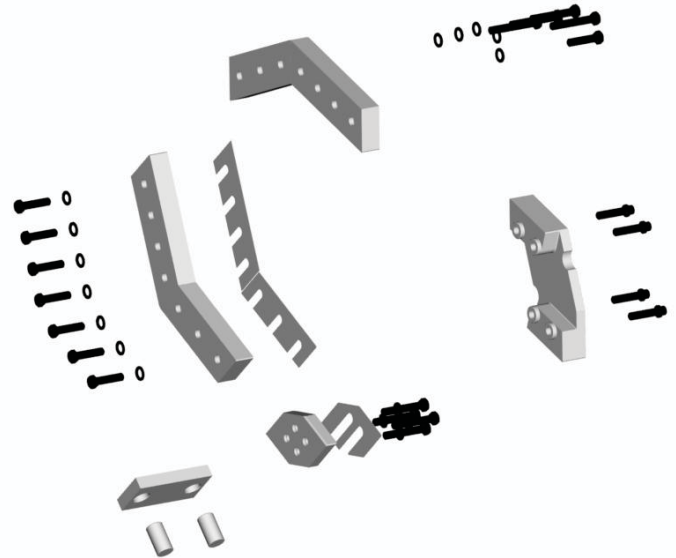

FIGURE 5-7

MSD SABER SERIES SHEARS

GUIDE BLADE SHIMMING AND ROTATION

The guide blade gap is another adjustment that keeps the shear blades in line and ensures the proper operation of the shear. This adjustment should be checked daily.

1. Close the shear until the Saber Tip on the upper shear begins to bypass the guide blade (see **Figure 5-8**). Use a feeler gauge to check the gap and record it. Close the shear in steps and check the gap at different spots along the Saber Tip surface.
2. Find the smallest gap along the Saber Tip and mark it. The gap at this spot should not exceed 0.030" (0.76 mm). If the gap is more than this, it will be necessary to shim the guide blade.
3. Guide blade shims are provided with a new shear. The shim kit includes four shims that are 0.024" (0.61 mm) thick and one that is 0.12" (3 mm) thick.
4. To determine the amount of shims to use, subtract the desired gap of 0.010" (0.25 mm) from the smallest gap that was recorded earlier. See the example at the right side of this page.

WARNING

Do not check gaps while the shear is in motion. Stay clear when closing the shear or severe injury could result.

CAUTION

Wear gloves at all times during blade maintenance.

NOTICE

- If the guide blade is stuck in its seat, refer to the Blade Removal procedure in this section.
- If the shear has been operated for more than 80 hours since the last blade rotation, it is recommended that all blades be rotated at this time. Follow the instructions on this page and the following pages.

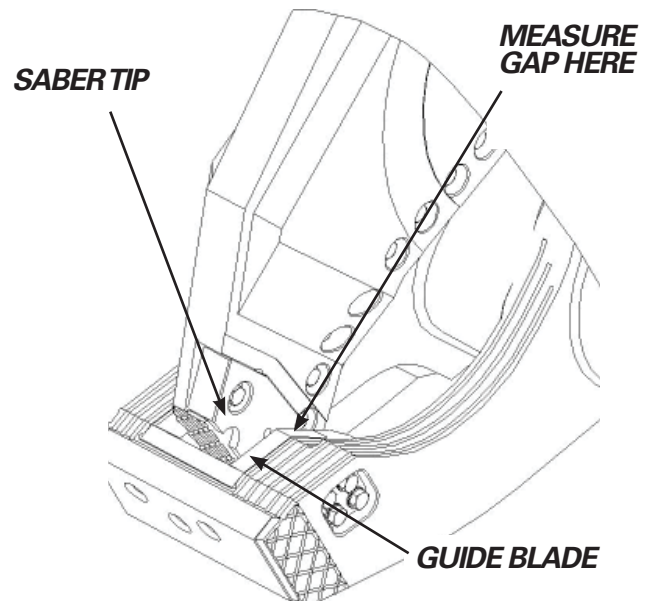

FIGURE 5-8

Example:

Recorded Gaps:

0.035" (0.89mm)

0.040" (1.02 mm)

0.045" (1.14 mm)

Smallest Gap = 0.035"

Minus Desired Gap - 0.010"

Shim Amount = 0.025"

For this example, one of the 0.024" (0.61 mm) thick shims would be used to achieve the desired guide blade gap.

GUIDE BLADE SHIMMING AND ROTATION continued

5. To shim the blade, loosen the guide blade bolts and move the guide blade out far enough to slide the shims between the blade seat and the guide blade. If all five shims are installed and the gap still exceeds 0.030" (0.76 mm), it will be necessary to rotate or replace the guide blade.
6. The guide blade can be rotated once so the whole face of the blade can be used to increase its life. When it is time to rotate the blade, remove it and turn it end for end, and place it back in its seat. The same face should be used for the entire life of the blade. Use the steps above to shim the guide blade to the correct gap. When the whole face of the blade is worn and it cannot be shimmed anymore, it is time to replace it with a new one.
7. If a gap greater than 0.030" (0.76 mm) still exists with a new guide blade and a full set of shims, the Saber Tip will need to be replaced. Refer to Cutting Blade Rotation in this section.

WARNING

Always wear proper safety equipment when doing blade maintenance. This includes eye protection, hard hat, steel toe shoes, work gloves and hearing protection. Wear an approved respirator when grinding.

CUTTING BLADE ROTATION PROCEDURES

Proper rotation and adjustment of the cutting blades is very important for the best shear performance and longer shear life. It is recommended that the blades be rotated after every 80 hours of use. Regular blade rotation keeps the blades and blade gaps uniform, which allows the blades to be shimmed properly. Regular blade maintenance is especially important when processing thinner materials. It may be necessary to rotate and adjust the cutting blades more often when processing thin or non-ferrous materials. Frequent rotation and adjustment of the cutting blades is not as critical when processing larger materials, but it will extend the life of the blades. Use the following instructions to properly rotate the cutting blades:

1. Use the Blade Removal instructions from this section to remove the upper shear blades. Take care to keep track of all parts and their positions as you remove them. This will be important when reinstalling.
2. Once the blades are removed, use a small grinder to clean up the edges. Remove sharp burrs and smooth out deformations. Clean out the blade seats in the same way, removing any debris or burrs.

NOTICE

*For optimal Saber Tip performance, and to assure that two flat surfaces are torqued together, the upper secondary blade should always be new at each blade position change. To accomplish this, do the following: Use first edge of new shear (all blades new), rotate all blades end-for-end in original location. Use second edge and then discard lower primary blade. Move upper secondary blade to lower primary position and install new blade in the upper secondary position. Swap positions of the upper primary and lower secondary. Continue this sequence, discarding the lower primary and installing a new upper secondary at each blade position swap. This results in an optimal Saber Tip performance at the one time cost of an additional upper secondary blade (after two edges are used). See **Figures 5-9 and 5-10** on page 5-18.*

MSD SABER SERIES SHEARS

CUTTING BLADE ROTATION

continued

The startup kit for every new shear contains two extra blades. Keep these blades for the second time you rotate edges and replace blades. For the first rotation, you'll only need the original four blades; the second time, you'll be using new blades.

CAUTION

If you follow these directions correctly, each time you order a new set of four blades you'll be setting aside two blades for a second rotation—at every second blade flip, two new blades will be inserted in the top blade seats. NEVER ROTATE USED LOWER BLADES INTO UPPER BLADE SEATS.

NOTICE

Never operate a shear when the blade edges have rounded to a 1/4" (6 mm) radius or more. Operating the shear with badly worn blades greatly decreases shear performance and can eventually cause structural and hydraulic damage to the shear.

1. See **Figure 5-9**. Turn each original blade end-for-end and return each one to its original seat. When done, you have completed the procedure for the first blade edge rotation.
2. See **Figure 5-10**. For the second blade edge rotation (when edges have rounded to a 1/4" radius), remove and discard the lower blades. Next, remove the two upper blades, swap end-for-end, and install in the lower seats. Now install two new blades in the open upper seats.
3. Whenever you rotate or replace cutting blade edges, make sure all blades are seated properly and use a new set of blade bolts and torque according to the Dry Bolt Torque Chart in this section. Always use the same size and class of bolts. Refer to your Parts Catalog to order replacement bolts from your authorized Stanley LaBounty dealer.
4. Cross blade and guide blade maintenance should be performed when lower blades are being rotated. Keep track of all parts and their positions as you remove them to make reinstallation easier.

FIRST AND THIRD BLADE EDGE ROTATION

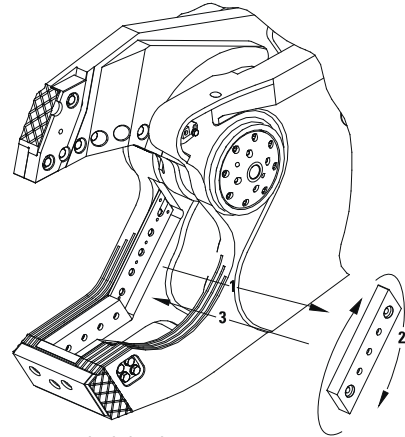

1. Remove each blade.
2. Turn end for end.
3. Reinstall in same seat.
4. Replace Saber Tip as required.

FIGURE 5-9

SECOND BLADE EDGE ROTATION

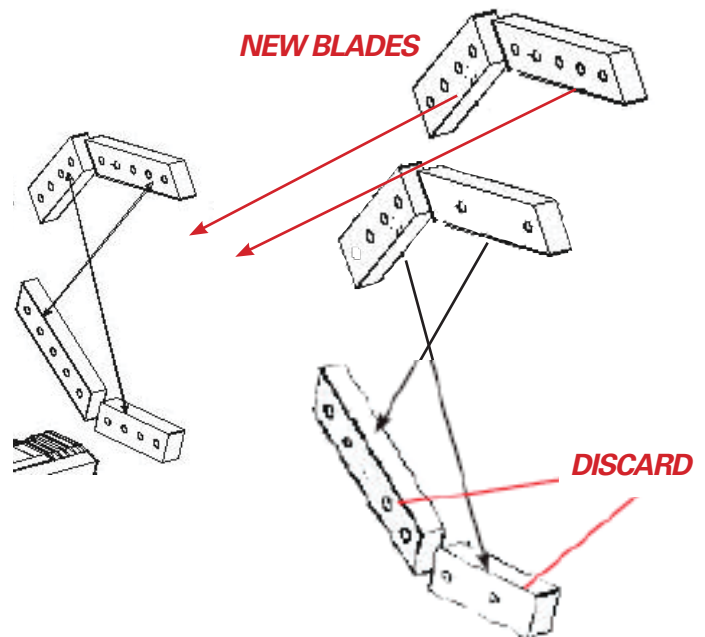

1. Discard lower blades.
2. Rotate upper blades to lower blade seats.
3. Install two new blades in upper seats.

FIGURE 5-10

CUTTING BLADE ROTATION

continued

NOTICE

The holes in the front of the cross plate can be used to dislodge the cross blade from its seat. Place a soft metal punch or pin through these holes and up against the blade. Strike the punch with a mallet to dislodge the blade.

6. Use a small grinder to clean up the blade edges. Remove sharp burrs and smooth out deformations. Clean out the blade seats in the same way, removing any debris or burrs.
7. The cross blade can be rotated one time to increase its life. If the current cross blade has not already been rotated once, turn it end for end and place it back in its seat. If the cross blade has already been rotated once, it will need to be replaced.
8. If there were shims behind the cross blade when it was removed, make sure to reinstall them (see **Figure 5-12**). Replace any damaged shims. Tap the face of the blade with a soft-faced mallet to make sure that it seats firmly.
9. Like the cross blade, the guide blade can be rotated one time to increase its life. If the current guide blade has not already been rotated once, turn it end for end and place it back in its seat. Only use one face of the guide blade before replacing.

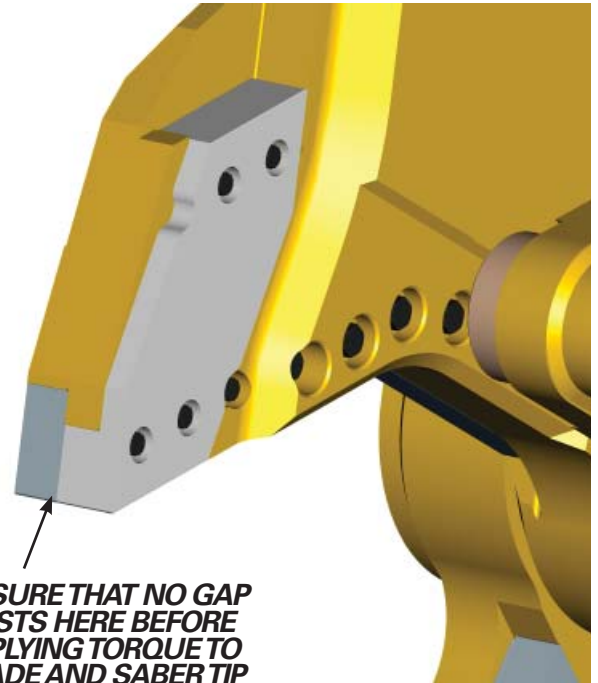

ASSURE THAT NO GAP EXISTS HERE BEFORE APPLYING TORQUE TO BLADE AND SABER TIP BOLTS

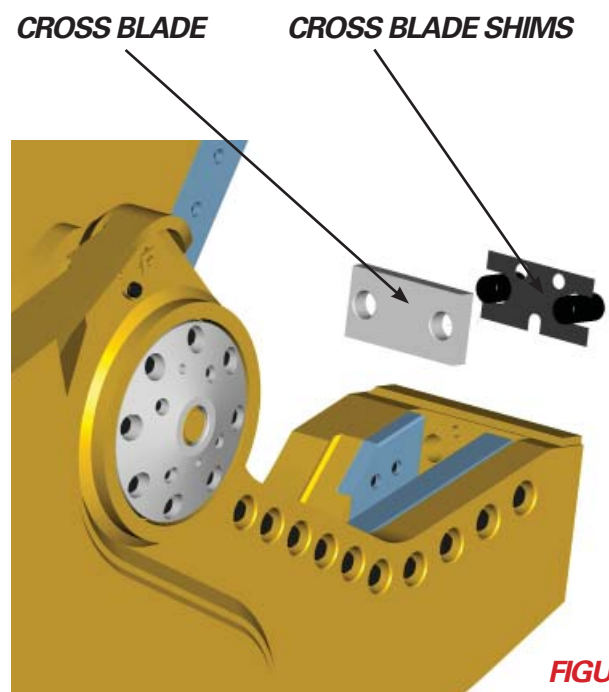
FIGURE 5-11**FIGURE 5-12**

MSD SABER SERIES SHEARS

CUTTING BLADE ROTATION

continued

10. After rotation or replacement, place the guide blade back in its seat without shims. Use a new set of guide blade bolts and tighten them until snug. **Do not apply torque to the bolts yet.** Make sure the blade is seated snugly.

11. Rotate the lower cutting blades according to the Blade Rotation Sequence diagrams on page 5-18.

12. Make sure the adjustment plate is reinstalled properly and then place the blades into their proper positions without shims. Use a new set of blade bolts and tighten until snug. **Do not apply torque to the bolts yet.** Ensure the blades are seated snugly.

NOTICE

The adjustment plate behind the lower cutting blades must be reinstalled properly for the blades to be aligned. The notched end of the adjustment plate should be toward the throat (Figure 5-13).

13. The guide blade and lower cutting blades are now ready for shimming. **DO NOT** operate the shear without shimming the guide blade and cutting blades to the proper blade gaps.

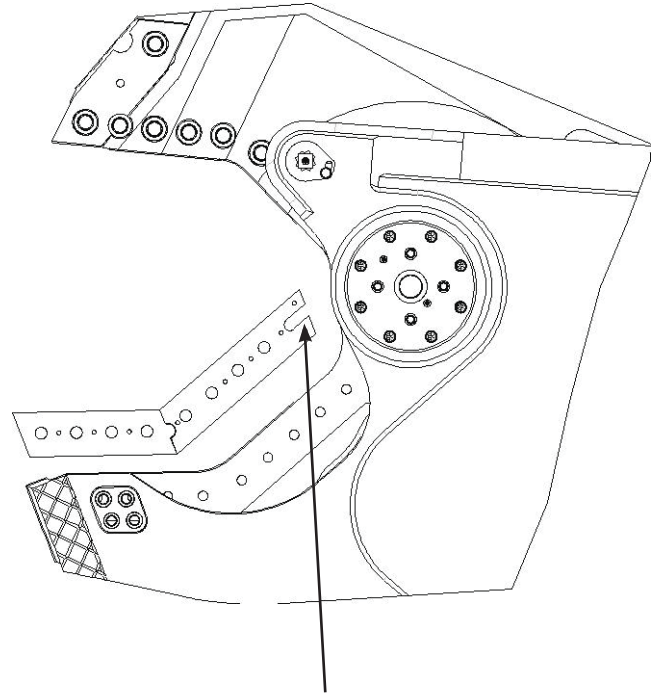

ADJUSTMENT PLATE NOTCH TOWARD SHEAR THROAT

FIGURE 5-13

WELD-IN TIP CUTTING BLADE ROTATION PROCEDURE

Proper rotation and adjustment of the cutting blades is very important for the best shear performance and longer shear life. It is recommended that the blades be rotated after every 80 hours of use.

FIRST AND THIRD BLADE EDGE ROTATION

FIGURE 5-16



1. Remove each blade.
2. Turn end for end.
3. Reinstall in **same** seat.
4. Replace Weld-In Tip as required.

SECOND AND FOURTH BLADE EDGE ROTATION

FIGURE 5-17

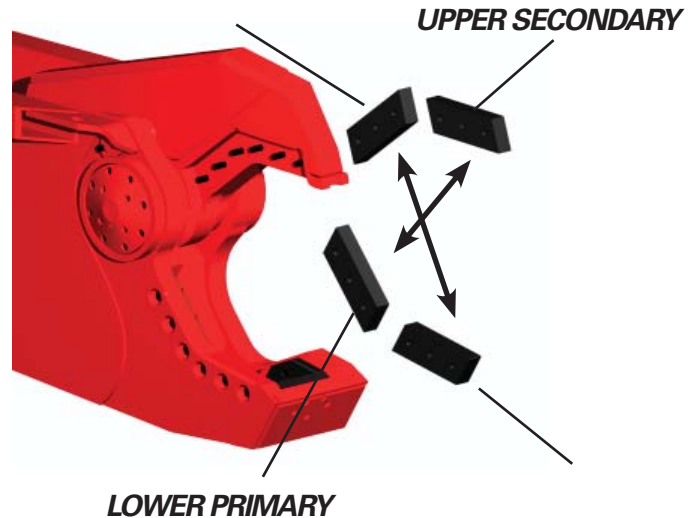

1. Remove all blades.
2. Swap the blade positions.
3. Replace Weld-In Tip as required.

NOTICE

Never operate a shear when the blade edges have round to a 1/4" (6 mm) radius or more. Operating the shear with badly worn blades greatly decreases shear performance and can eventually cause structural and hydraulic damage to the shear.

1. Keep track of all parts and their positions as you remove them. This will be important when reinstalling.
2. Once the blades are removed, use a small grinder to clean up the edges and blade seats, remove sharp burrs and smooth out deformations.
3. See **Figure 5-16**. Turn each original blade end-for-end and return each one to its original seat. When done, you have completed the procedure for the first blade edge rotation.
4. See **Figure 5-17**. For the second blade edge rotation (when edges have rounded to a 1/4" radius), swap the blade positions (primary to secondary and secondary to primary).
5. Whenever you rotate or replace cutting blade edges, make sure all blades are seated properly and use a new set of blade bolts and torque according to the Dry Bolt Torque Chart in the SOM. Always use the same size and class of bolts. Refer to your Parts Catalog to order replacement bolts from your authorized Stanley LaBounty dealer.
6. Cross blade and guide blade maintenance should be performed when lower blades are being rotated. Keep track of all parts and their positions as you remove them to make reinstallation easier.

MSD SABER SERIES SHEARS

CUTTING BLADE SHIMMING

After blade rotation, use the following instructions to shim to the proper blade gap. Shimming is necessary if the gap exceeds 0.030" (0.75 mm). For most shearing applications, this gap should be maintained at 0.010" to 0.020" (0.25 to 0.50 mm), **but see the table below for the specific gap for your shear.** The gap may be shimmed down to 0.005" (0.13 mm) if jamming becomes a problem, especially when processing thin materials. Shim only the lower blades.

1. To check for blade gap, close the shear until the secondary blades in the upper and lower shear begin to bypass (see **Figure 5-18**). Start with the thickest shims and check to see how many shims can be slipped between the blades and record this amount. Another method is to use a feeler gauge to check the blade gap and record it.
2. The whole shim set adds up to 0.125" (3.2 mm). If all shims can be slipped between the blades it will be necessary to replace the blades. Do not shim the lower blades out more than 0.125" (3.2 mm). This may cause structural damage to the shear.
3. Close the shear further until the primary blades begin to bypass (see **Figure 5-19**). Again, check to see how many shims can be slipped between the blades (or use the feeler gauge). Record this gap also. If the blades have been rotated properly at the correct intervals, the blade gap should be even over the entire span of the blades. If the gap is not even, contact your Stanley LaBounty dealer.
4. Once the blade gap is checked and recorded, open the shear. Shim the lower blades by using the same amount of shims that you were able to slip between the blades earlier.
5. To install the shims, loosen the lower blade bolts and move the blades out slightly. Slide the shims between the lower blades and the existing adjustment plate. Tighten the blade bolts until snug.
6. Cycle the shear slowly to the full-closed position. Check the gap at different points to make sure it is between 0.010" and 0.020" (0.25 and 0.50 mm). If it is too tight, you may need to remove a shim.
7. When the gap is correct, apply the correct torque to the blade bolts. Refer to the Dry Bolt Torque Charts in this section for the proper torque value.

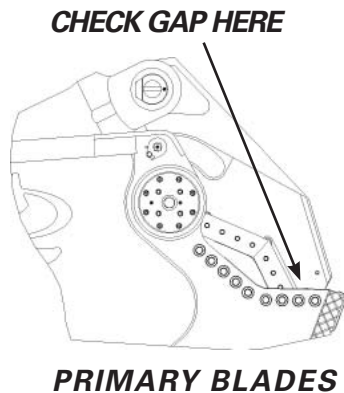

FIGURE 5-18

SHEAR MODEL	BLADE GAP
MSD1000	.010"
MSD1500	.010"
MSD2000	.010"
MSD2500	.010"
MSD3000	.010"
MSD4500	.020"
MSD7500	.040"
MSD9500	.060"

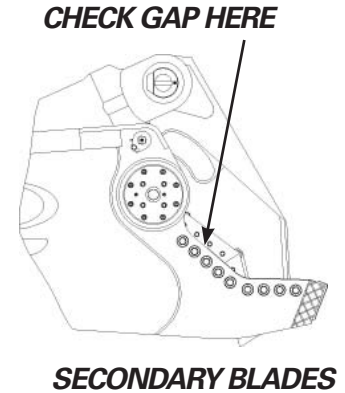

FIGURE 5-19

WARNING

Keep hands away from moving shear. Be sure the shear will not move while checking the blade gaps or severe injury could result.

GENERAL GUIDELINES FOR BUILD UP AND HARDSURFACING

The steel used in LaBounty Saber Series™ shears is stronger and more durable than ever. However, this steel requires special attention during maintenance. Pay special attention to the preheat and post-heat instructions and follow them exactly. Review the following guidelines for build-up and hardsurfacing the shear. Detailed instructions on maintaining specific areas of the shear are on the following pages.

PREHEAT

Preheat the general surrounding area to at least 200°F (100°C) to remove moisture from the base material.

NOTICE

Before ANY thermal process is applied to the shear steel, including welding, tack welding, torch cutting, and air-arcing, preheat the area within 6" (150 mm) of the local area to a minimum of 400°F (200°C) and a maximum of 450°F (230°C). This includes adding and removing lifting lugs.

Preheat must be uniform throughout the material thickness and maintained until all welding has been completed. Avoid cyclic heating and large temperature swings. Preheating may be done by localized gas torches, or thermal strip blankets.

POST HEAT

If preheat has dropped below 400°F (200°C) within 6 inches (150 mm) of the weld area, post heat to 400° (200°C) and wrap with heat blanket to allow it to cool slowly to the ambient temperature. Plan to perform build-up and hardsurfacing at the end of the day or when there will be adequate time for the welded areas to cool before placing the shear back into service.

HANDLING AND STORAGE OF WELD MATERIALS

Follow the weld manufacturer's handling and storage instructions closely. Make sure the electrodes or wire are free of moisture. Moisture can cause cracks and porosity in the weld and the base metal beneath the weld.

WELD QUALITY

Quality and attention to detail in welding can significantly affect the life of the shear. Stanley LaBounty strongly recommends that only qualified and certified welders perform this work. Make sure the weld consumables and base material are clean, dry, and free of grease, paint, dirt, or any other foreign substance that may harm the weld.

NOTICE

Preheat and post-heat instructions must be followed exactly. Failure to do so can compromise warranty coverage.

NOTICE

Using improper build up and hardsurfacing products may result in premature wear or increased potential for cracking and may compromise warranty coverage.

MSD SABER SERIES SHEARS

BUILD UP RECOMMENDATIONS

Refer to the list of AWS classifications below to select a suitable build-up material for LaBounty shears. Weld products within these classifications meet the combined requirements for strength, toughness, and ductility that are essential for LaBounty applications.

Shielded Metal Arc Welding - Stick Electrodes

- E7018
- E8018-C 3

Gas Metal Arc Welding - Solid Wire Electrodes

- ER 70S-6

Gas Metal Arc Welding - Flux Cored Electrodes

- E71 T-1
- E71T-1M
- E80T1-Ni1
- E80T1-Ni1M
- Innershield NR-233

Gas Metal Arc Welding - Metal Powder Cored Electrodes

- E70C-6M
- E80C-Ni1

Welding suppliers can assist in identifying products that meet these AWS classifications.

HARDSURFACING RECOMMENDATIONS

For hardsurfacing, Stanley LaBounty recommends Amalloy 814H rod or equivalent. It is important to always use a hardsurfacing weld material with a chromium content of less than .10 percent and a severe impact-resistance rating to prevent cracking. If you have questions about what hardsurface material to use, please contact the Stanley LaBounty Customer Service Department.

Failure to adhere to LaBounty hardsurfacing recommendations may compromise the attachment warranty. Hardsurfacing should be applied directly on top of the build-up welds. The build up acts as a bonding or underlayment for the hardsurfacing, which reduces the chances that the hardsurfacing will crack.

Contact Information for **Amalloy Welding and Industrial Supply**

Phone: 800-735-3040 (toll free)

Fax: 763-753-8263

Web site: amalloy.com

NOTICE

DO NOT use stainless hardsurface rod. It will crack the base metal which can cause a major structural failure of your shear jaws.

CRITICAL WEAR AREAS

NOTICE

The area shown in **Figure 5-20** must be inspected daily, and maintained whenever the crosshatch pattern is almost worn down to the base metal surface. If you have any questions regarding this information, please call the Stanley LaBounty Service Department at (218)-834-6901.

Close attention must be paid to the “crosshatch” hardsurfacing. This area should be inspected daily. When the crosshatch is worn down almost to the base metal surface, clean the surface by wire brushing, preheat to 400°, and apply new underlayment beads to the pattern using E-7018 welding rod, or E-70 series wire. After the pattern has been established with underlayment beads, apply hardsurface to the pattern. It is recommended that only one pass (bead) of hardsurfacing be applied. After welding, wrap the upper in a heat blanket and allow to cool slowly. Apply hardsurfacing on top of each of the underlayment beads. **DO NOT APPLY HARDSURFACE DIRECTLY TO THE PARENT MATERIAL.** It is important to use an air operated slag peener on each pass of weld to relieve stress.

If, as a result of production considerations, the crosshatch pattern has been worn down into the base metal of the shear upper jaw, the Saber Tip can be used as a guide for build-up to proper profile prior to applying new hardsurfacing. If the edge of the Saber Tip has been worn, it will be necessary to remove the tip, rotate to the new front edge, and bolt into place. The surface of the upper shear face should be built up (using E-7018 welding rod, or E-70 series wire-following pre-heat procedures) to conform in profile to the new Saber Tip edge. Depending upon the model, this surface should be flush with the Saber Tip edge to 1/16" above the edge. Once the surface has been built up and ground to profile, the crosshatch hardsurface pattern can be applied. Use 1 ½" spacing in the crosshatch hardsurface pattern, as shown in **Figure 5-20**.

NOTICE

Recommended Hardsurfacing Welding Rod for this application: Amalloy 814-H

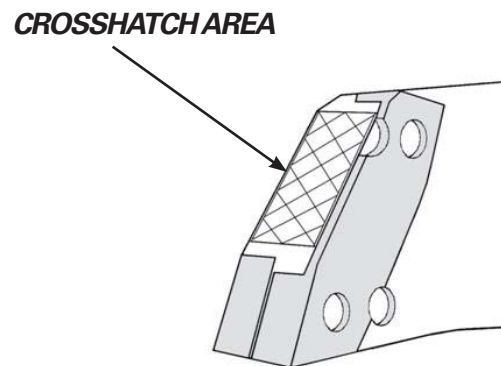

FIGURE 5-20

MSD SABER SERIES SHEARS

CRITICAL WEAR AREAS

continued

CROSSHATCH HARDSURFACING

See **Figure 5-21**.

A. In some applications, this area can be built up for added wear resistance. Taper and blend the top edge of the weld procedure.

B. Maintain build-up in this critical area. Area to be built up flush with the top edge of the blade. Use E-7018 or E-70 series wire.

C. Maintain profile and build-up in this area. Blend the bottom edge. This area must be maintained to prevent wear into the Saber Tip reverse edge, which rests just behind it.

D. Use E-7018 or E-70 series wire. Apply hardsurface allowing 1/16" space in from the edge both sides. Do not apply hardsurface directly on an edge.

E. Apply the crosshatch pattern using 1.50" spacing.

F. Build up this area so that the bottom edge protrudes 1/16" beyond the end of the blade. Taper and blend the top edge; use E-7018 or E-70 series wire.

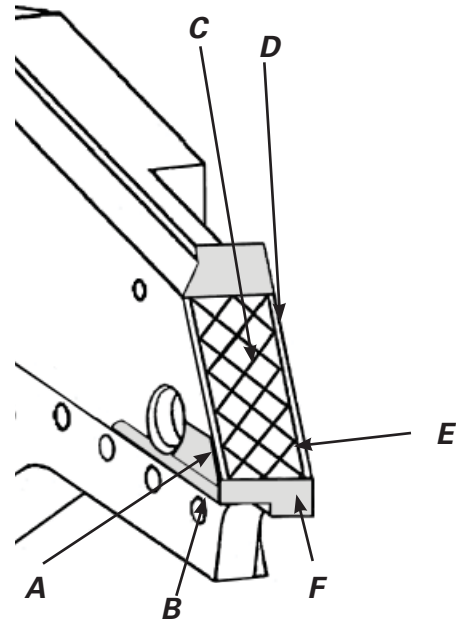

FIGURE 5-21

BUILD UP TEMPLATE

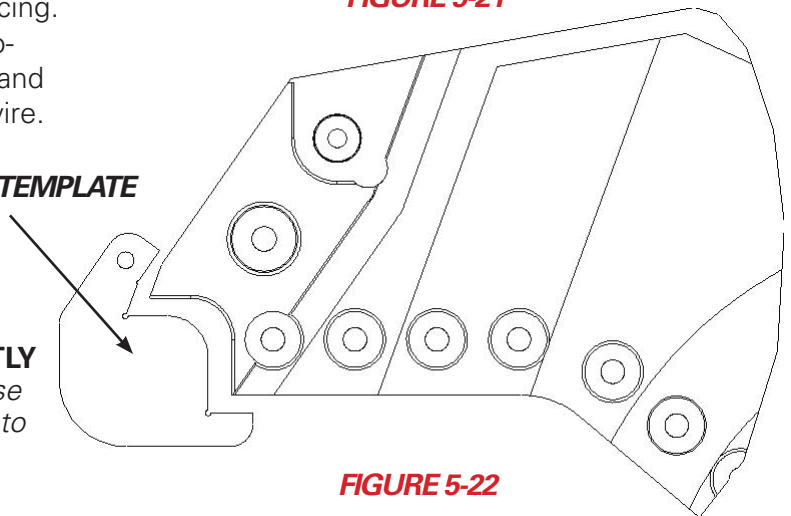

FIGURE 5-22

NOTICE

Apply hardsurfacing on top of the underlayment beads **DO NOT APPLY HARD SURFACE DIRECTLY TO THE PARENT MATERIAL.** It is important to use an air operated slag peener on each pass of weld to relieve stress.

NOTICE

- **Figure 5-22** is not to scale; it has been enlarged for the purpose of illustration.
- Apply hardsurfacing on top of the underlayment beads. **DO NOT APPLY** for all build-up and welding procedures; use E-7018 welding rod, or E-70 series wire, following the welding procedures outlined on pages 5-19 through 5-20 of this manual.
- Use build-up template provided in the maintenance kit, to profile upper.
- If restoring the profile of the tip pocket is unattainable through welding and grinding, please contact LaBounty Service Department: (800) 522-5059. There is a tip grinding tool that follows a template that will restore the seat to factory specifications.

UPPER SHEAR BUILD UP AND HARDSURFACING

1. Apply a bead of hardsurface rod on top of each of the underlayment beads. It is important to use an air operated slag peener on each pass to relieve weld stress.
2. To determine how much build up is required along the blade seats, place a straightedge across the blades. Repeat steps 4 and 5 to build this area flush with the blade (see **Figure 5-23**).
3. If necessary, build-up along the top and front edges of the secondary blade seat flush with the blade (see **Figure 5-24**). The blade should not stick out beyond the edge of the seat in this area.
4. To hardsurface the area alongside the upper blades, establish the pattern with three or four passes of build-up. These beads should run parallel to the blades from behind the Saber Tip to approximately the mid-point of the primary blade (see **Figure 5-25**).

NOTICE

- Keep the outside passes at least 1/4" (6 mm) back from the blade seat and outer edges.
- Stagger the ends of the welds and do not end a weld adjacent to a blade bolt hole.
- Use a grinder to taper the ends of each weld down to the base material. Grind marks should go with the grain.
- Do not undercut the ends of the weld with the grinder.

5. Apply hardsurfacing on top of each of the underlayment beads. Do not apply hardsurface directly to the parent material. It is important to use an air operated slag peener on each pass of weld to relieve stress.
6. If the temperature within 6" (150 mm) of the weld area has dropped below 400°F (200°C) during the weld process, post heat this area to 400°F (200°C).
7. Wrap with a heat blanket and allow the welded area to cool slowly to the ambient temperature. The shear should not be put back into service until it has cooled completely.

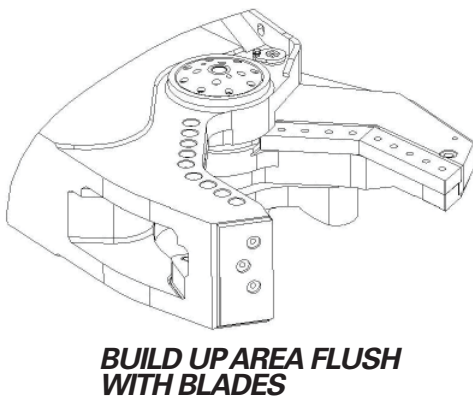

FIGURE 5-23

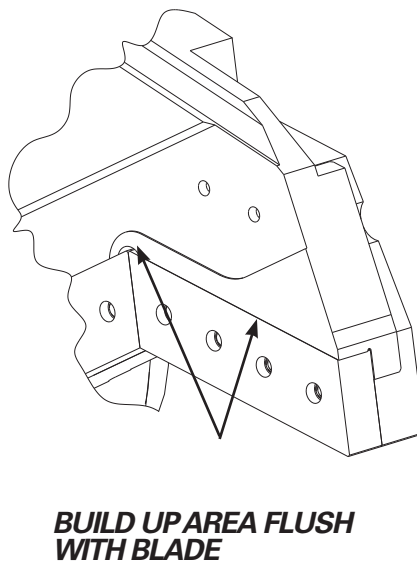

FIGURE 5-24

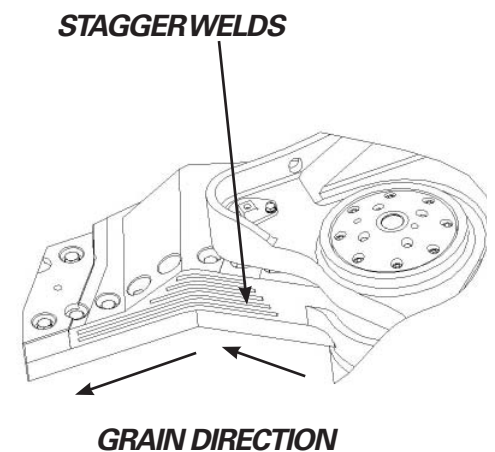

FIGURE 5-25

MSD SABER SERIES SHEARS

WELD-IN TIP MAINTENANCE

if equipped

Check the condition of the piercing tip daily. It should be square and fit closely between the blades of the lower shear. All blade maintenance should be completed before building up the piercing tip. The condition of the piercing tip has a large effect on the piercing ability of the shear. If the tip is worn, it is suggested that the tip be built up and hardsurfaced. If the tip is badly worn, it is recommended that a new piercing tip be installed. Instructions for replacing the tip are on the following pages. This maintenance should be done at the end of the work day to allow adequate cooling time before putting the shear back into production.

1. Use a straight edge to determine how much build-up is needed along the sides of the piercing tip. Place the straightedge along the cutting blades and extend it beyond the tip (see **Figure 5-26**). The tip should be flush with the blades.
2. Now do the same on the other side of the upper shear. The tip should be flush with the front wear plate (see **Figure 5-27**). If there is a gap, this area needs to be built up.
3. Use the build-up template provided by Stanley LaBounty to determine the amount of build-up needed on the front and bottom surfaces of the tip. Line up the template with the edges of the cutting blade and check the wear (see **Figure 5-28** on page 31).
4. Clean all dirt and grease from area to be built up.
5. Preheat the area surrounding the tip to about 200°F (100°C) to remove moisture. Preheat the area within 6 inches (150 mm) of the weld location to a minimum of 400°F (200°C) and a maximum of 450° (230°C). Maintain this temperature range throughout the process.

⚠ WARNING

The upper shear must be grounded when welding on the upper shear to prevent the possibility of electric shock and arcing through the cylinder or main pivot components.

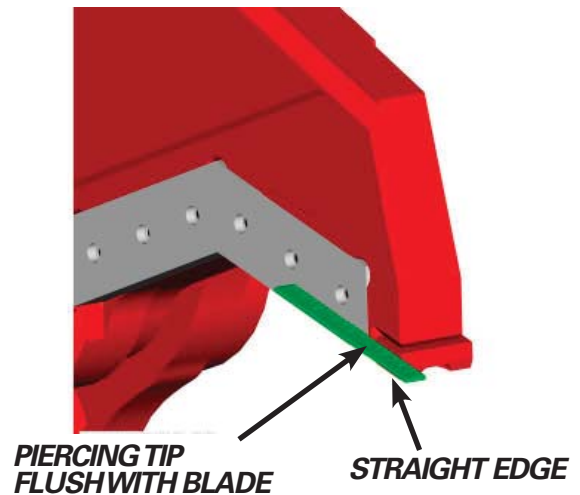

FIGURE 5-26

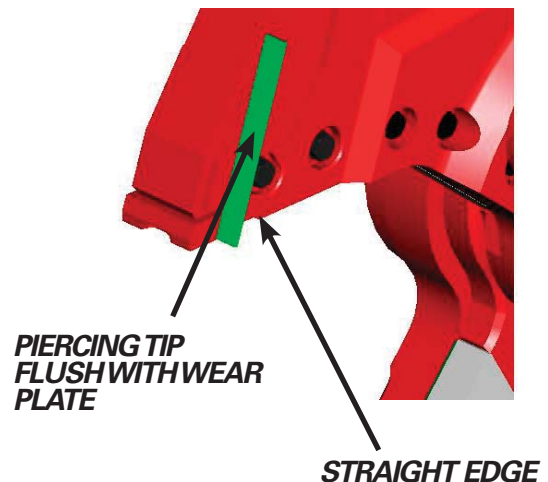

FIGURE 5-27

WELD-IN TIP MAINTENANCE

continued

6. Apply build up to the worn areas (see General Rules for Build Up and Hardsurfacing). Peen each pass vigorously to relieve weld stress and remove slag.

NOTICE

Check temperature frequently during this procedure. Maintain 400-450°F (200-230°C). Do not exceed 450° (230°C).

7. To hardsurface the built up area, apply single passes, side by side. Peen each pass.

8. When welding is complete, grind the tip smooth and square with wear plate and cutting blades. Check it again with the straight edge and build-up template.

9. To check the fit of the tip, close the shear until the piercing tip begins to enter the lower shear (see **Figure 5-29**). The piercing tip should fit squarely into the lower jaw.

10. When finished reworking the tip, work harden it by peening the welded area until it is shiny or until the peener cannot dent the weld anymore (approximately five minutes).

11. If the temperature within 6" (150 mm) of the weld area has dropped below 400°F (200°C) during the weld process, post heat this area to 400°F (200°C).

12. Wrap with a heat blanket and allow the welded area to cool slowly to the ambient temperature. The shear should not be put back into service until cooled.

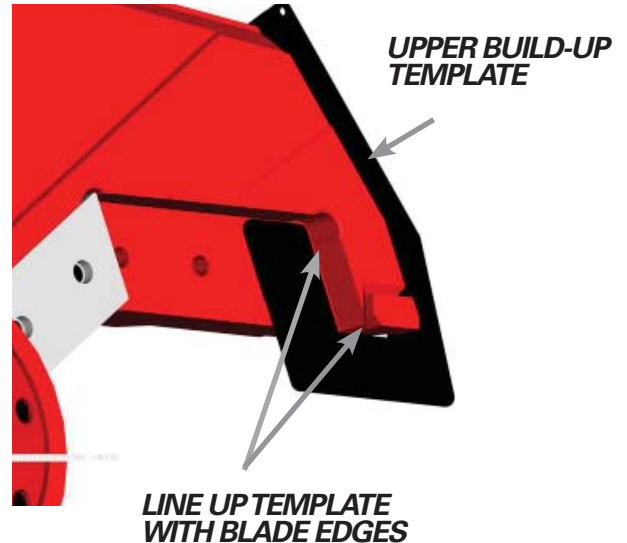

FIGURE 5-28

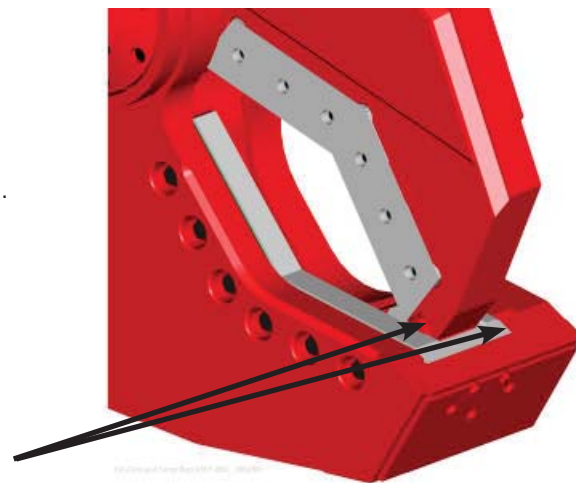

FIGURE 5-29

MSD SABER SERIES SHEARS

WELD-IN TIP REPLACEMENT

if equipped

If the piercing tip is badly worn, it is advisable to install a new piercing tip using the following instructions.

NOTICE

If the front wear plate is also worn, replace it at the same time as the piercing tip.

1. Preheat the surrounding area to about 200°F (100°C) to remove moisture. Preheat the area within 6" (150 mm) of the tip to a minimum of 400°F (200°C) and a maximum of 450°F (230°C). Maintain this temperature range throughout the process.
2. Air-arc the old tip to remove it. Be sure to remove the old tip completely. Please note that a notch or seat for the tip is present in the upper shear.
3. To completely prepare the surface for the new tip, the upper must be chamfered as shown (see **Figure 5-30**). The chamfer size should be approximately one-half the thickness of the new tip.

NOTICE

Before installing the new piercing tip, grind the area flat and smooth. Remove carbon residue with the air-arc.

4. Place the new tip into the seat. Use a straightedge to position the tip before tacking it into place. The side edge of the new tip should be flush with the face of the blade (see **Figure 5-31**).
5. Make sure the tip is squarely against the edge. Once the tip is positioned properly, bring the preheat back up to 400°F (200°C) and tack the tip in place.
6. Check the tip profile with the build up template supplied by Stanley LaBounty (see **Figure 5-32**).
7. Close the shear until the tip begins to enter the lower shear and check the clearance of the new tip. If clearance is correct, proceed with the following steps. If not, adjust the position of the tip as needed.

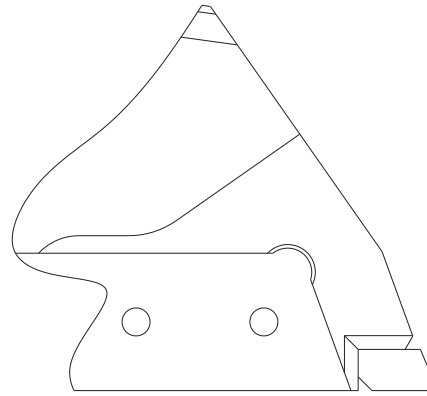

FIGURE 5-30

45° CHAMFERS

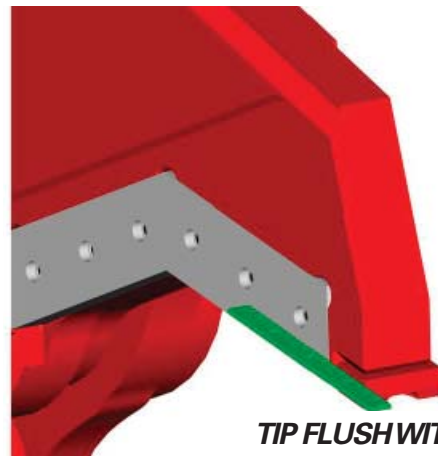

FIGURE 5-31

TIP FLUSH WITH BLADE

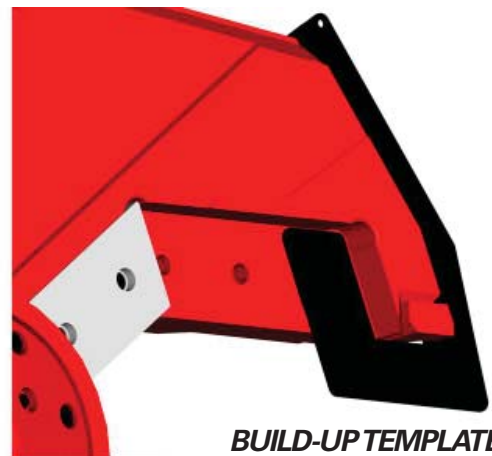

FIGURE 5-32

BUILD-UP TEMPLATE

WELD-IN TIP REPLACEMENT continued**⚠ WARNING**

The upper shear must be grounded when welding on the upper shear to prevent the possibility of electric shock and arcing through the cylinder or main pivot components.

NOTICE

Check temperature frequently during this procedure. Maintain 400-450°F (200-230°C). Do not exceed 450° (230°C).

- 8.** Once it is tacked in the proper position, preheat the tip area to a minimum of 400°F (200°C) and a maximum of 450°F (230°C).
- 9.** Use the recommended build-up weld rod to fill the chamfered areas with multiple passes. Do the sides first and stress relieve each pass by peening. A weld is required on both sides of the tip (see **Figure 5-33**).
- 10.** Weld the back and front to the upper shear, following the same procedure.
- 11.** Grind the welds flush on the sides. The weld on the wear plate side should be ground flush with the front wear plate.
- 12.** If the temperature within 6" (150 mm) of the area has dropped below 400°F (200°C) during the weld process, post heat this area to 400°F (200°C).
- 13.** Wrap with a heat blanket and allow the welded area to cool slowly to the ambient temperature. The shear should not be put back into service until it has cooled.

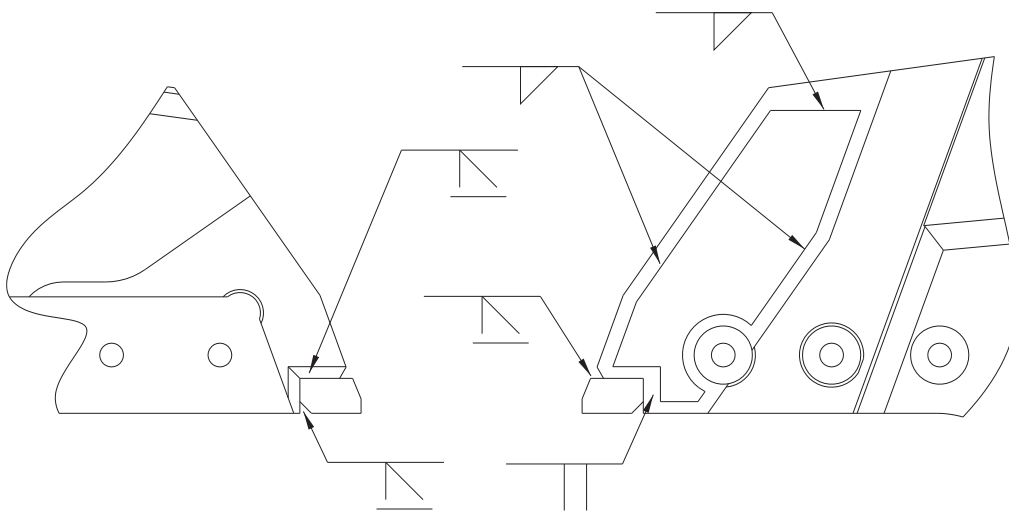
**FIGURE 5-33**

MSD SABER SERIES SHEARS

FRONT WEAR PLATE REPLACEMENT

if equipped

The front wear plate bears against the guide blade to support the upper shear during operation (see **Figure 5-34**). To prevent damage to the shear, it is crucial to replace this wear part when it is worn. Replace the front wear plate when the guide blade gap is greater than 0.030" (0.75 mm) with a new guide blade and a full set of shims installed. Whenever the front wear plate is replaced, also replace the piercing tip. Use the following instructions to replace the front wear plate.

1. Preheat the area surrounding the wear plate to about 200°F (100°C) to remove moisture. Preheat the area within 6" (150 mm) of the wear plate to a minimum of 400°F (200°C) and a maximum of 450° (230°C). Maintain this temperature range throughout the process. Temperature/melt sticks are available from Stanley LaBounty.
2. Air-arc the old wear plate to remove it completely. Please note that the upper shear has a machined surface for the wear plate.
3. Use a grinder to make sure the area is flat and smooth with all carbon residue removed.
4. Place the new wear plate into the machined area existing on the upper. Position the new wear plate so there is approximately 1/2" (12.7 mm) gap between the wear plate and the piercing tip, and equal distances on the other sides of the seat. Clamp the wear plate into position.
5. Bring the preheat back up to 400°F (200°C) and tack the tip in place.

⚠ WARNING

The upper shear must be grounded when welding on the upper shear to prevent the possibility of electric shock and arcing through the cylinder or main pivot components.

NOTICE

Check temperature frequently during this procedure. Maintain 400-450°F (200-230°C). Do not exceed 450° (230°C).

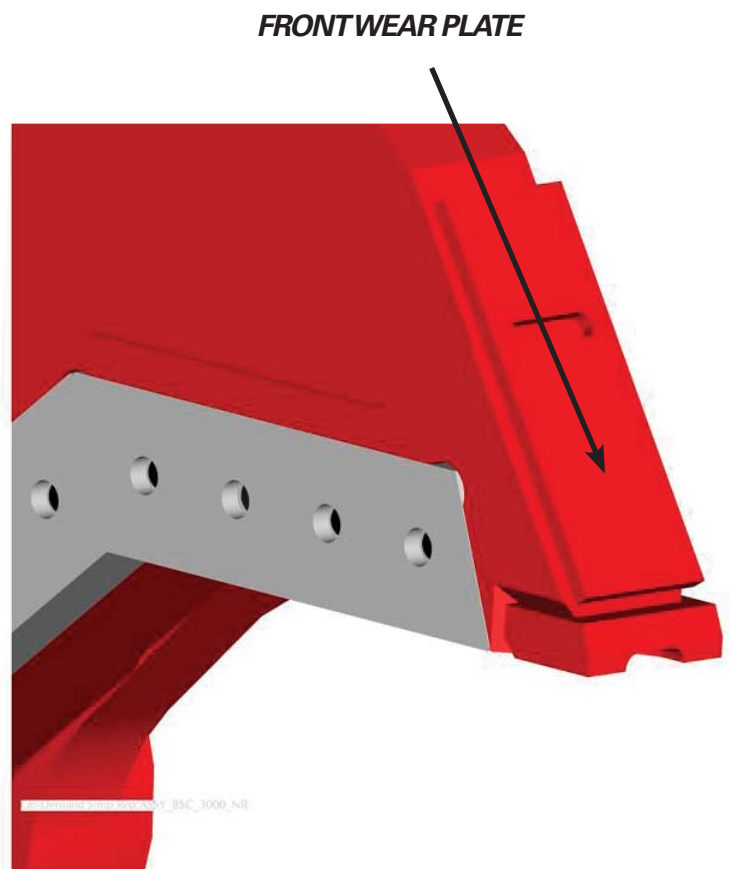

FIGURE 5-34

LOWER WEAR PLATE REPLACEMENT

The lower wear plates protect the lower cross plate from excessive wear. Inspect these plates every 80 hours and replace them before the cross plate is in danger of being exposed to wear. Use the following instructions to replace the lower wear plates.

1. Preheat the surrounding area to about 200°F (100°C) to remove moisture. Preheat the area within six inches (150 mm) of the lower wear plates to a minimum of 400°F (200°C) and a maximum of 450° (230°C). Maintain this temperature range throughout the process. Temperature/melt sticks are available from Stanley LaBounty.
2. Air-arc the old wear plates to remove them completely from the nose plate.
3. Use a grinder to make sure the surfaces are flat and smooth with all weld and carbon residue removed. If necessary, build up the edges of the cross plate before installing the new wear plates. See the lower shear build-up instructions in this chapter.
4. Position the new front wear plate so it is centered across the width of the cross plate. The holes in the wear plate should be aligned with the holes in the nose plate. This should leave a gap between the top of the wear plate and the top of the nose plate that will be filled with weld later (see **Figure 5-35**). Clamp the wear plate into position, bring the pre-heat back up to 400°F (200°C). Tack weld in place.

NOTICE

Lower wear plates have been added to the sides of the cross plate in 1000, 1500 and 2000 Saber Shears.

NOTICE

Check temperature regularly during this procedure. Maintain 400-450°F (200-230°C). Do not exceed 450°F (230°C).

WARNING

The lower shear must be grounded when welding on the lower shear to prevent the possibility of electric shock.

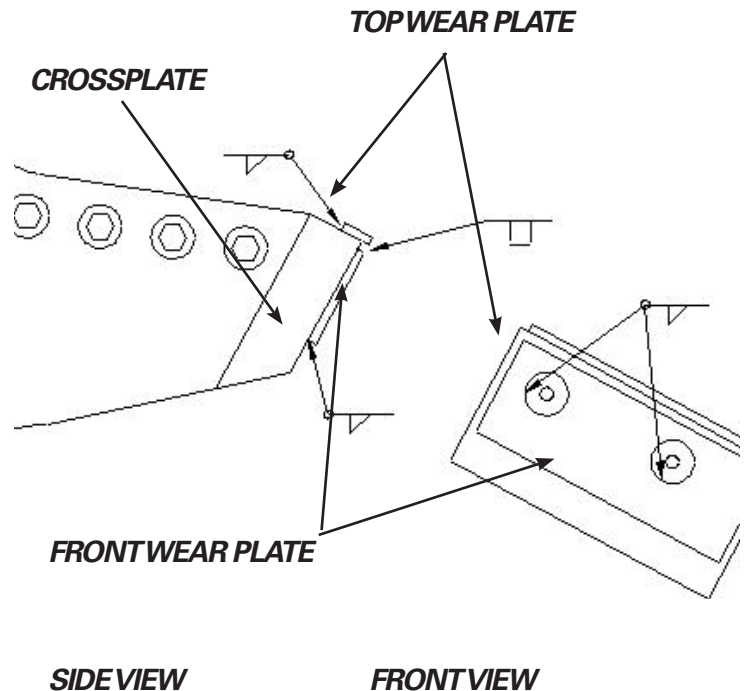

FIGURE 5-35

MSD SABER SERIES SHEARS

LOWER WEAR PLATE REPLACEMENT continued

5. Position the new top wear plate so it is also centered across the width of the cross plate. This wear plate should overhang the front edge of the cross plate to be flush with the face of the front wear plate. Clamp the wear plate into position, bring the preheat back up to 400°F (200°C) and tack weld in place.
6. Use the recommended build-up weld rod to fill the area between the wear plates. Then weld an approximate 3/8" (10 mm) fillet on all remaining sides around the wear plates. Also weld a fillet around the inside of the holes on the front. Stress relieve each pass by peening. Grind welds smooth.
7. If the temperature within 6" (150 mm) of the weld area has dropped below 400°F (200°C) during the weld process, post-heat this area to 400°F (200°C).
8. Wrap with a heat blanket and allow the welded area to cool slowly to the ambient temperature. The shear should not be put back into service until it has cooled completely.

LOWER SHEAR BUILD UP AND HARDSURFACING

For maximum performance and long life, all edges on the lower shear should be kept square and flush with the blades. Check the lower shear every 80 hours and maintain it when necessary. All blade maintenance must be done before building up and hardsurfacing the lower shear. It is recommended that this maintenance be done at the end of the working day to allow adequate cooling time before putting the shear back into service.

1. Remove all existing hardsurfacing by grinding down to the base metal. Do not weld on top of the existing hardsurfacing.
2. Clean all dirt and grease from area to be maintained.
3. Use a straight edge to determine how much build-up is required on the cross plate. If the lower wear plates on the nose plate are worn, these should be replaced at this time (see previous page for instructions).
4. Use the straight edge across the top of the blades to find the build-up requirements on the top side of the lower shear. All edges should be square.
5. Preheat the area surrounding the tip to about 200°F (100°C) to remove moisture. Preheat the area within 6" (150 mm) of the weld location to a minimum of 400°F (200°C) and a maximum of 450° (230°C). Maintain this temperature range throughout the process.

⚠ WARNING

The lower shear must be grounded when welding on the lower shear to prevent the possibility of electric shock and arcing through the cylinder or main pivot components.

LOWER SHEAR BUILD UP AND HARDSURFACING

continued

6. Apply build up to the worn areas in single passes, side-by side, running with the grain of the base material (see General Rules for Build Up and Hard-surfacing). Use the air-operated slag peener to peen each pass to relieve weld stress and remove slag. Grind all edges to 90°.

NOTICE

Check temperature regularly during this procedure. Maintain 400-450°F (200-230°C). Do not exceed 450°F (230°C).

7. If necessary, build up the area beneath the edge of the secondary blade so it is flush with the blade (see **Figure 5-37**). The blade should not stick out beyond the edge of the seat in this area.

8. To hardsurface the top sides of the lower shear, establish the pattern with three or four passes of build-up. These beads should run parallel to the blades from the nose plate back to about the mid-point of the primary blade. Do this on the guide blade side also. This will establish the hardsurfacing pattern and serve as an underlayment.

9. Apply a bead of hardsurface rod on top of each of the underlayment beads. **DO NOT** apply hardsurface directly to the parent material. It is important to use an air operated slag peener on each pass of weld to relieve stress.

USE STRAIGHT EDGE
ACROSS SURFACES

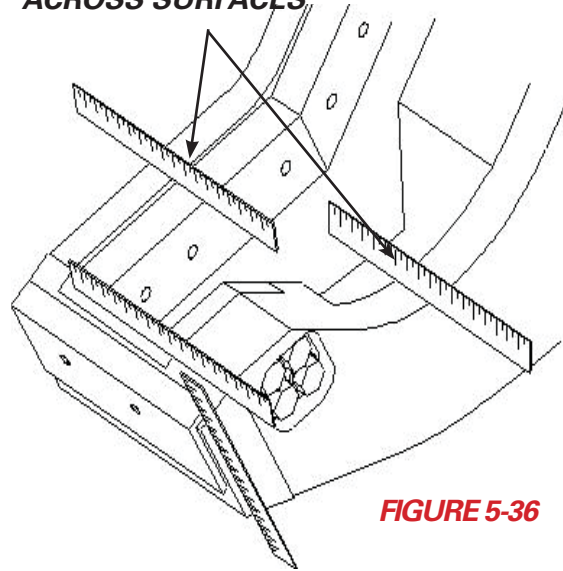

FIGURE 5-36

BUILD UP AREA FLUSH WITH
BLADE

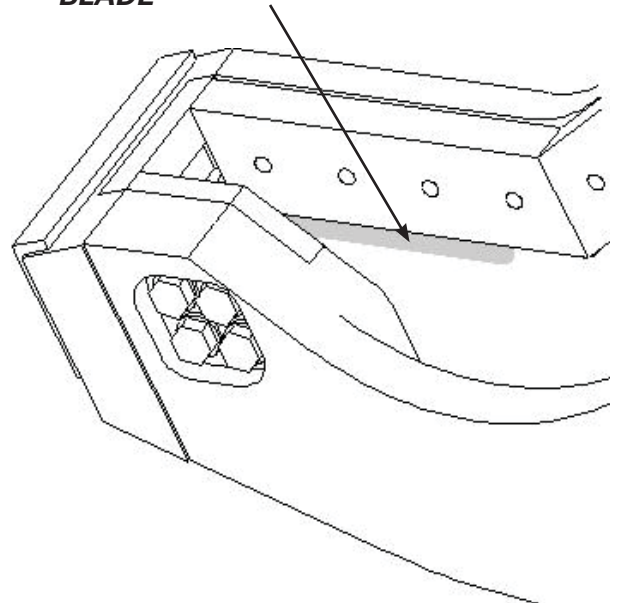

FIGURE 5-37

MSD SABER SERIES SHEARS

LOWER SHEAR BUILD UP AND HARDSURFACING

continued

NOTICE

- Keep the outside passes at least 1/4" (6 mm) back from the blade seat and outer edges.
- Stagger the ends of the welds and do not end a weld adjacent to a blade bolt hole. See **Figure 5-38**.
- Use a grinder to taper the ends of each weld down to the base material. Grind marks should go with the grain.
- Do not undercut the ends of the weld with the grinder.

10. Use a similar technique to hardsurface the sides of the nose plate. Establish a 45° diamond pattern of approximately 1-1/2" (38 mm) (see **Figure 5-39**). Again, use the build-up rod to lay down the pattern and use the hardsurface rod on top. Use the air-operated slag peener to peen each pass to relieve weld stress and remove slag.

11. If the temperature within 6" (150 mm) of the weld area has dropped below 400°F (200°C) during the weld process, post heat this area to 400°F (200°C).

12. Wrap with a heat blanket and allow the welded area to cool slowly to the ambient temperature. The shear should not be put back into service until it has cooled completely.

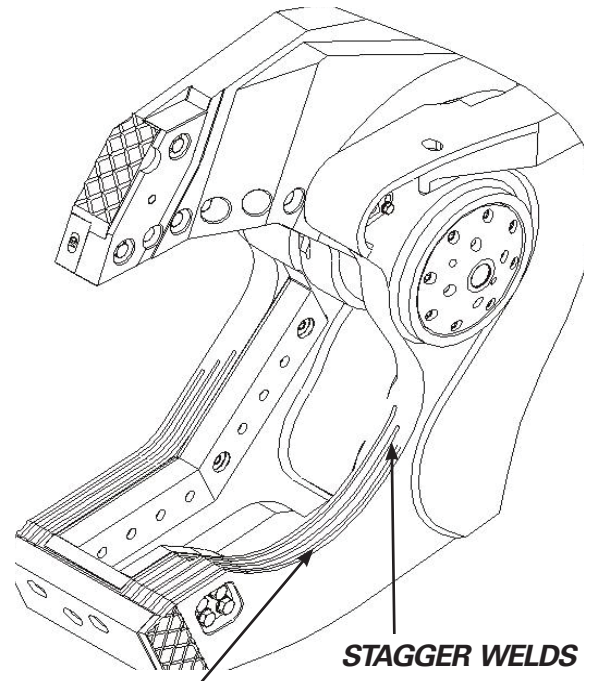

FIGURE 5-38

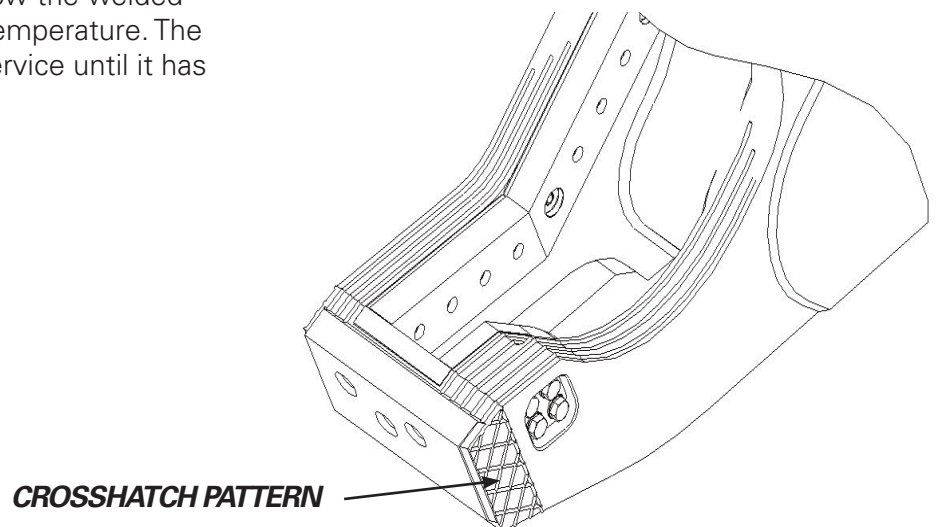

FIGURE 5-39

HYDRAULIC SYSTEM MAINTENANCE

Use the following instructions to safely perform hydraulic checks and maintenance on the shear.

1. Always relieve all excavator hydraulic pressure before working on any hydraulic component. Relieve hydraulic pressure before working on the machine by working the controls in all directions with the engine off.
2. In order to test the hydraulic system, a diagnostic fitting will need to be installed into the shear hydraulic manifold block. To do this, shut off the excavator and relieve the system pressure. Make sure the system pressure is at zero (0) psi and remove the dash-4 (1/4") O-ring boss plug from the diagnostic port on the hydraulic manifold block. Replace this plug with a diagnostic fitting for your test gauge. Maintaining proper operating pressure will result in the best cutting performance. This is also a quick check to make sure that the excavator is performing up to specifications.
3. Check all hydraulic components (split flanges, hoses, fittings, mounting hardware, etc.) every 80 hours.
4. Have the shear cylinder seals replaced by an authorized Stanley LaBounty dealer every 2,000 hours.
5. Whenever hydraulic lines are disconnected, hoses must be capped and ports must be plugged to prevent contamination of the hydraulic system.

WARNING

Relieve pressure before disconnecting hydraulic lines. Tighten all connections before applying pressure. Keep hands and body away from pin holes and nozzles, which can eject fluids under high pressure. Use a piece of cardboard to search for leaks. Escaping fluid under pressure can penetrate the skin and cause serious injury. If ANY fluid is injected into the skin, seek immediate medical attention.

NOTICE

NEVER adjust pressure relief valves to get higher operating pressures. The manufacturer's recommended pressures give the safest performance with the longest life.

MSD SABER SERIES SHEARS

FLANGE TYPE HOSE FITTINGS

Check flange fittings for smooth, tight fit of matching surfaces. If any cap screws are loose or matching surfaces are not tight, tighten the loose cap screw then tighten the diagonally opposite cap screw. Tighten the two remaining cap screws then torque all four screws as specified in the Torque Chart in this manual.

Tolerance is $\pm 10\%$. The torques given are enough for the given size connection with the recommended working pressure. Torques can be increased to the maximum shown for each screw size if desired. **DO NOT** use these values if a different torque value or tightening procedure is listed for a specific application. Torque values listed are for general use only. Check tightness of cap screws periodically.

Shear bolts are designed to fail under predetermined loads. Always replace shear bolts with identical grade. To prevent them from failing when tightening, make sure fastener threads are clean and properly engaged.

TORQUE VALUES FOR FOUR-BOLT FLANGE FITTINGS

CODE 62 FLANGES

NOMINAL FLANGE SIZE	CAPSCREW SIZE	TORQUE FT-LBS	TORQUE N-M
1"	M12x1.75	70	95
1 1/4"	M12x1.75	70	95
1 1/4"	M14x2.00	112	152
1 1/2"	M16x2.00	224	304
2"	M20x2.50	435	590



Use only metric tools on metric hardware. Other tools may not fit properly. They may slip and cause injury.

NOTICE

Do not use air wrenches. Tighten each bolt equally in an alternating pattern. Do not over tighten.

CODE 61 FLANGES

NOMINAL FLANGE SIZE	CAPSCREW SIZE (CLASS 10.9)	TORQUE FT-LBS	TORQUE N-M
3/4"	M10x1.50	42	57
1"	M10x1.50	42	57
1 1/4"	M12x1.75	70	95
1 1/2"	M12x1.75	70	95
2"	M12x1.75	70	95

APPLYING SPLIT FLANGE CLAMPS

1. Clean sealing surfaces and make certain they are free from nicks, scratches and burrs. Foreign material prevents a proper seal (see **Figure 5-40**).



FIGURE 5-40

4. Torque the fasteners in diagonal sequence, in small increments, until final torque level is achieved. Torque values for flange connections are listed on page 34. Notice that the torque values vary according to the size and fastener type.



FIGURE 5-42

2. Lubricate the o-ring and ensure that it is properly installed so as to prevent damage during installation.

3. Push the flange clamps toward the flange head and screw fasteners into flange pad. Continue to screw the fasteners until their heads just meet the split flange surface (see **Figure 5-41**).

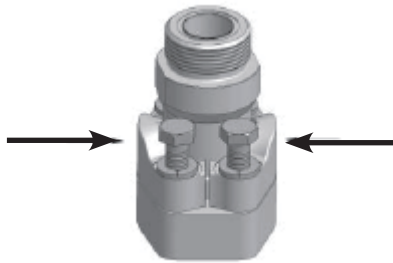

FIGURE 5-41

MSD SABER SERIES SHEARS

CYLINDER GAP CHECK

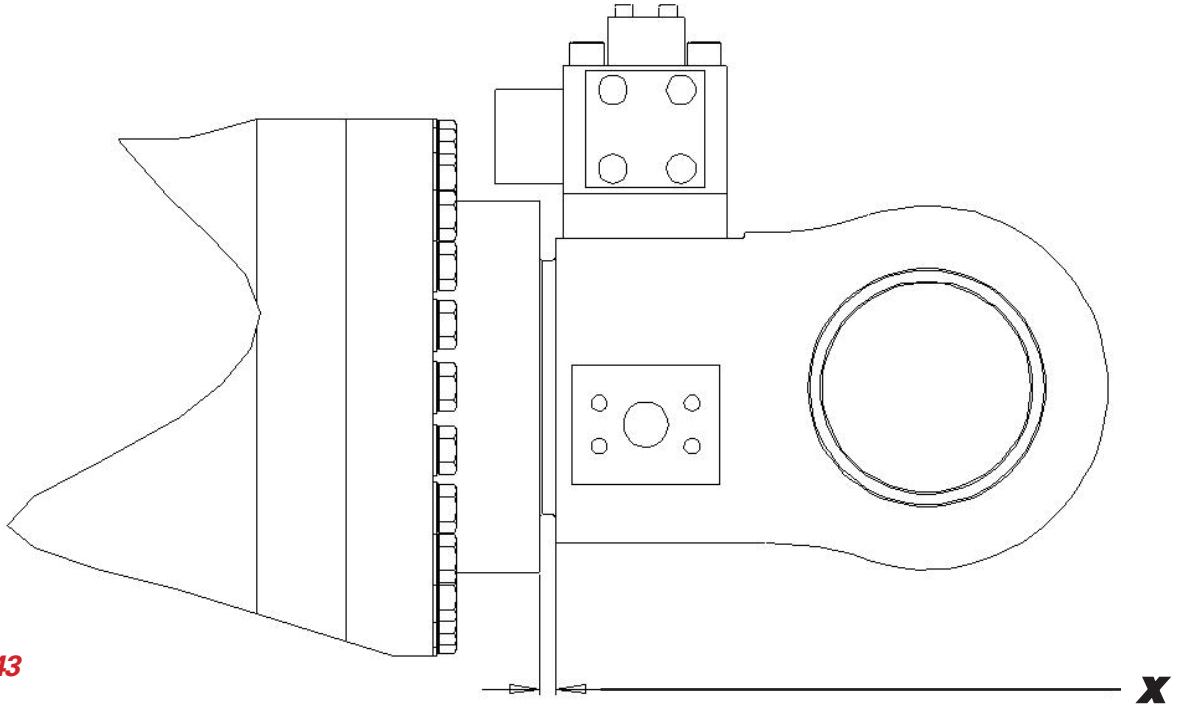

FIGURE 5-43

Periodically check (minimum once per week) the gap between the rod eye shoulder and head face (X) with the cylinder fully retracted (see **Figure 5-43**). If the gap exceeds the dimensions given in the table, below, by more than .06", it could be an early indication of required maintenance. Stop shear operations and call the LaBounty Service Department: (218)-834-6901.

MODEL	X-DIMENSION
1500	0.50"
2000	1.50"
2500	0.50"
3000	0.50"
4500	1.00"
7500	0.75"
9500	0.75"

HYDRAULIC SCHEMATIC - STANDARD ROTATING SHEARS

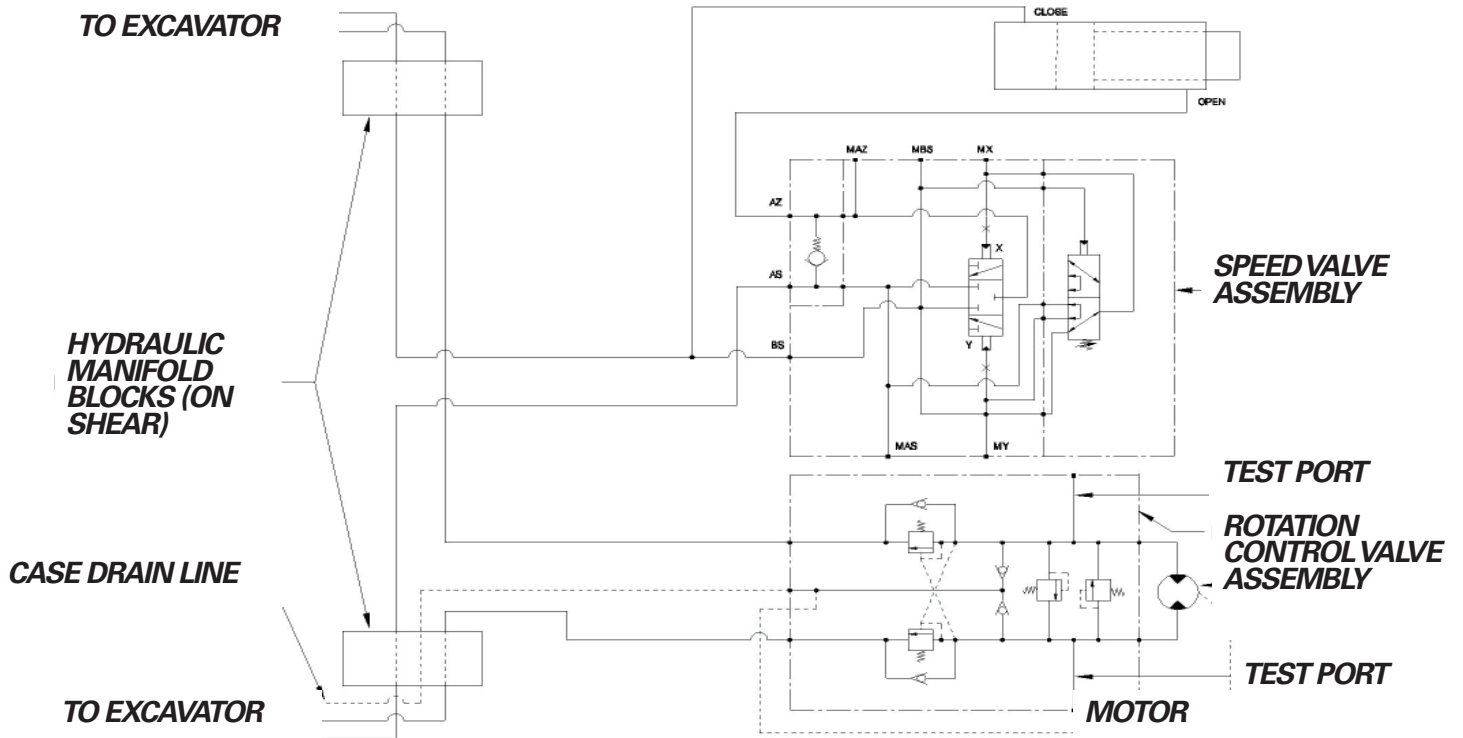

FIGURE 5-44

HYDRAULIC SCHEMATIC - STANDARD NON-ROTATING SHEARS

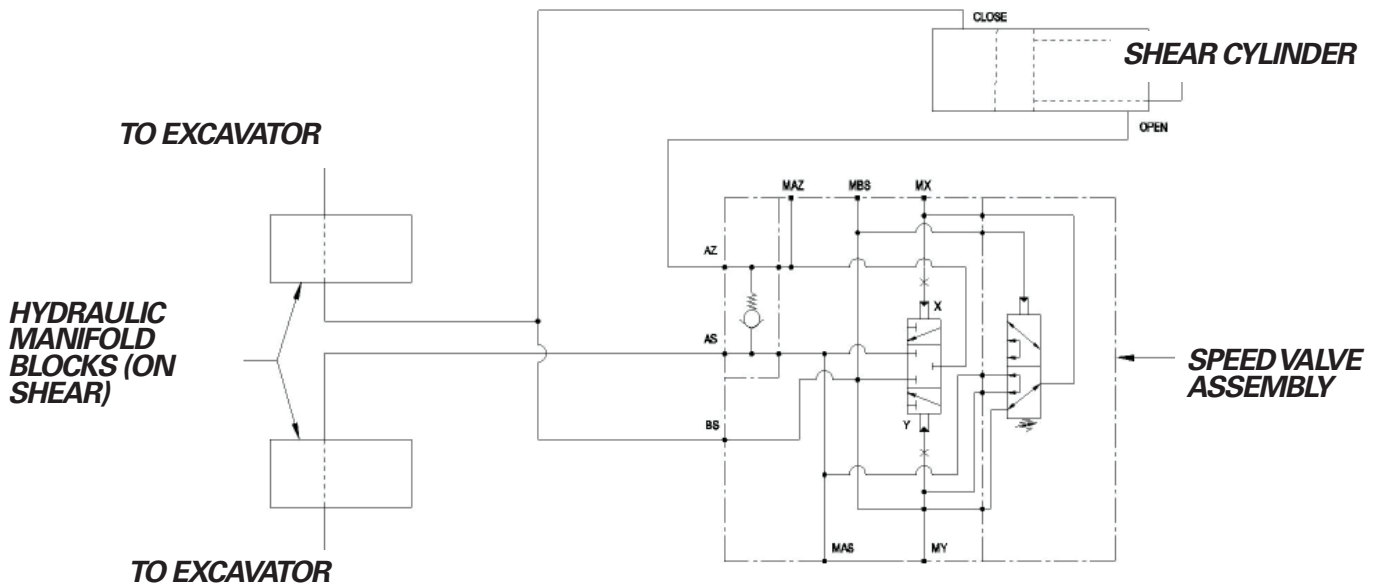

FIGURE 5-45

MSD SABER SERIES SHEARS

SPEED VALVE ADJUSTMENT

The speed valve on LaBounty® shears is factory adjusted by Stanley LaBounty technicians prior to shipment. Field adjustments of the valve should only be necessary if the operator senses that the valve is not functioning properly. Some indicators of a poorly functioning valve are:

- The shear does not consistently shift into speed mode when closing the jaw
- The shear jaw continues to close after the operator has let go of the controls
- The shear shifts into speed mode, but seems to lack power

Follow the procedure below if speed valve adjustment is necessary.

TOOLS NEEDED

The following tools are recommended for speed valve adjustment on any Stanley LaBounty Saber Series Hydraulic Cylinder:

1. Open-end or box end wrenches (12-19 mm sizes)
2. Digital gauge kit (Stanley LaBounty P/N 169832)
3. Allen wrenches (4-12 mm sizes)

SAFETY POINTS

Stanley LaBounty recommends that the following safety precautions be followed when adjusting the speed valve on any Stanley LaBounty Saber Series Hydraulic Cylinder.

Reminder: Always wear the proper personal protection equipment including the following:

1. Steel toe safety shoes or boots.
2. Shatter proof safety glasses and head wear such as a hard hat.

3. Insulating gloves for low and high temperatures.
4. Overalls or other uniform—no loose fitting clothing that may become entangled in machinery
5. Hearing protection—ear muffs or plugs.

⚠ WARNING

Relieve pressure before disconnecting hydraulic lines. Tighten all connections before applying pressure. Keep hands and body away from pin holes and nozzles, which can eject fluids under high pressure. Use a piece of cardboard to search for leaks. Escaping fluid under pressure can penetrate the skin and cause serious injury. If ANY fluid is injected into the skin, seek immediate medical attention.

⚠ WARNING

DO NOT let hydraulic oil get in contact with the skin as it could cause severe burns. Hydraulic oil becomes hot during operation. Wear adequate protective clothing and safety equipment.

⚠ CAUTION

Chemicals used on Stanley LaBounty Saber Series hydraulic cylinders include hydraulic oil; refer to the excavator operator's manual and have MSDS sheets and proper treatment equipment available.

SPEED VALVE ADJUSTMENT continued**REGENERATIVE VALVE DESIGN**

The design of the regenerative flow valve used in Stanley LaBounty Mobile Shears consists of a pilot valve mounted onto a spool valve. The pilot valve is used for regulating the movement of the spool valve in shifting the valve into and out of regenerative mode. See **Figure 5-46**. The only component that is in the working flow path of the fluid to the shear cylinder is the valve spool. The valve spool is of similar construction to that of the excavator's main control valve spool. Therefore, it is considerably larger than the components found in a typical cartridge type regenerative valve.

OPERATING CHARACTERISTICS

The function of the regenerative valve is to provide for rapid advance of the shear hydraulic cylinder during the closing phase of the shear cycle. The valve accomplishes this function by shifting a valve spool to open the rod side of the cylinder to the bore side of the cylinder, thus allowing the fluid in the rod side to fill the bore side when the cylinder is extending. This function only occurs when the cylinder is advancing in a "low load" condition, which occurs as the shear jaw is closing down onto the material that it is about to be cut. As the shear enters the cutting phase, the operating pressure requirements increase. The pilot valve portion of the regenerative valve, which in turn causes the valve spool to shift out of regenerative mode, senses the increased pressure. During this phase, the rod-side fluid is directed to the work line and back to the base machine's reservoir (low pressure). Meanwhile, only the flow from the excavator's control valve is directed to the bore side of the cylinder, allowing it to reach full system operating pressure. This allows the shear to cut by utilizing the full power of the excavator with resistance coming only from the material being cut by the shear.

TROUBLESHOOTING

There are two operating conditions that affect the performance of the speed valve and will require some troubleshooting by an equipment mechanic or service representative. These conditions are:

- a.** The speed valve does not seem to shift out of regenerative mode at the appropriate time resulting in the shear appearing to lose cutting power, or
- b.** The speed valve does not appear to shift into regenerative mode resulting in a slow closing movement of the shear jaw. Both of these conditions can be remedied by following the speed valve adjustment procedure discussed on the following pages.

NOTICE

If making the appropriate adjustments does not remedy the above conditions, refer to page 6-11 of this manual for further troubleshooting guidelines. If further difficulties are encountered, the speed valve may require replacement of the hydraulic seals. Seal kits are available from the Stanley LaBounty Customer Service Department. Shear serial number will be required when ordering.

MSD SABER SERIES SHEARS

SPEED VALVE ADJUSTMENT continued

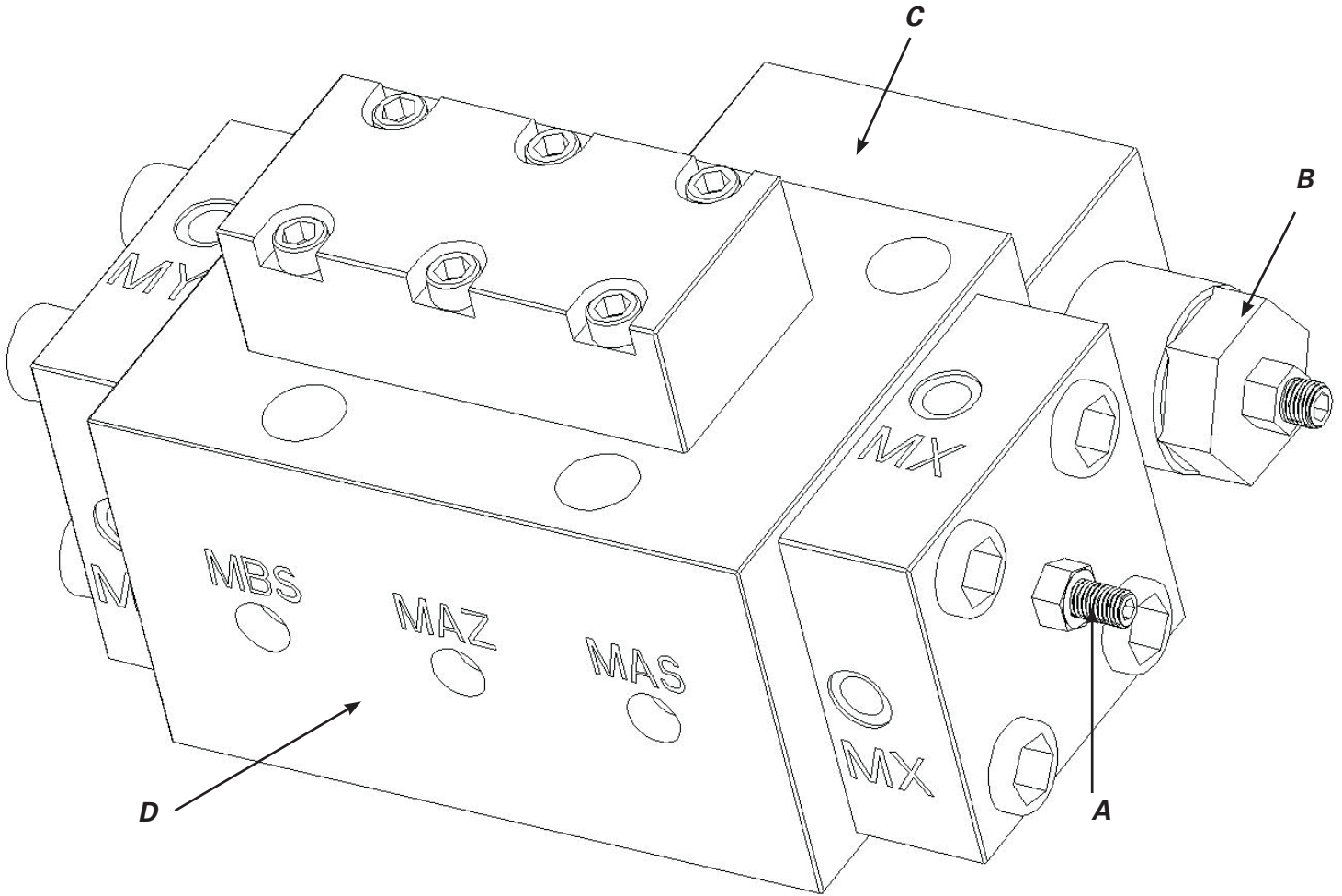

FIGURE 5-46*

- A. MAIN SPOOL VALVE ADJUSTMENT**
- B. PILOT VALVE**
- C. PILOT VALVE HOUSING**
- D. MAIN SPOOL HOUSING**

*Your speed valve may vary slightly from this isometric illustration, which is not to scale.

SPEED VALVE ADJUSTMENT

continued

The following procedure is recommended by Stanley LaBounty for speed valve adjustment on any fully assembled and installed Saber Series Hydraulic Cylinder. Prior to making any adjustments to the valve, verify whether the valve is operating properly by checking the following operational conditions. For condition "a" (as described on page 5-43), install a pressure gauge into the MAZ test port to see if the pressure drops to zero when fully closing the shear jaw. For condition "b" (as described on page 43), compare the closing speed of the shear to the opening speed. If the closing speed is equal to, or less than the opening speed, then the valve is shifting properly into the regenerative speed mode.

WARNING

This procedure requires more than one individual in close proximity to the shear and shear operation. Keep within sight when operating the shear. Ensure all persons are clear before cycling the shear. This procedure requires adjustments to be performed with the hydraulic system pressurized.

1. Position the attachment on firm, level ground so the speed valve is easily accessible.
2. Turn the excavator off and release all hydraulic pressure to the shear by working the excavator controls in all directions. Be certain to relieve the air pressure in the excavator reservoir. Refer to the excavator operator's manual for proper excavator hydraulic pressure relief procedures.
3. Slowly remove the plugs from the MBS port and the MAZ port on the speed valve. Turn the plugs counterclockwise until fluid begins to seep from the port. Allow the fluid seepage to slow before continuing.
4. Continue to slowly turn the plugs counterclockwise, pausing momentarily in 1/4 to 1/2 turn intervals until the plug is removed. This ensures all residual pressure is relieved from the speed valve. Refer to the illustration on page 5-44 of this section

for port locations. Place a drainage basin below the ports to capture all escaping fluid.

5. Install the test fittings supplied with the Stanley LaBounty Digital Gauge Kit, P/N 169832 into the MBS and MAZ ports on the Speed Valve. If the MAZ port is too difficult to access for test fitting installation, the MX port on the speed valve may also be used to monitor valve pressure.
6. Attach the digital gauge and pressure line to the MAZ test port on the speed valve. If two gauges are available, install the second digital gauge and pressure line to the MBS test port on the speed valve. If only one digital gauge is available, the MBS test port on the speed valve must be plugged at this time with the MBS port plug. Mechanical, liquid filled dial gauges may be used to monitor pressure in place of the digital gauges.
7. Reset the main spool valve adjustment by loosening the 19mm lock nut on the main spool valve, and turning the 6mm socket head adjustment screw counter-clockwise. Continue to turn the socket head adjustment screw until the end of its travel is reached, then turn the adjustment clockwise until you feel the spring tension of the main spool, after tension is felt turn the adjustment one full turn clockwise. Re-tighten the 19mm lock nut.
8. Loosen the 19mm lock nut on the pilot valve, but **DO NOT** turn the 6mm socket head pilot valve adjustment screw.
9. Have a co-worker restart the excavator. Check for leaks in the test fittings by using a piece of cardboard or other rigid material. Repair all leaks before proceeding.

NOTICE

Note that turning the pilot valve adjustment screw past the locking nut could cause severe damage to the pilot valve.

MSD SABER SERIES SHEARS

SPEED VALVE ADJUSTMENT continued

10. Have the excavator operator cycle the shear to the fully closed position and set the pilot valve to its maximum setting. Turn the pilot valve adjustment screw clockwise until the cylinder just fails to shift out of speed mode. You may need to open and close the shear multiple times to reach the pilot valve maximum setting. The pressure gauge attached to the MAZ port should read approximately 400 psi or higher when in speed mode.

NOTICE

DO NOT make adjustments to the speed valve while the cylinder is extending.

11. Have the excavator operator cycle the shear to the fully closed position then set the pilot valve to its minimum setting. Turn the pilot valve adjustment screw counter-clockwise until the cylinder just fails to shift into speed mode. You may need to open and close the shear multiple times to reach the pilot valve minimum setting. The pressure gauge attached to the MBS port should read approximately full system pressure when not in speed mode. Pay careful attention to the number of turns required to reach this setting.

12. Have the excavator operator return the shear to the fully open position a second time. Re-adjust the pilot valve adjustment screw to the final setting by turning the adjustment screw clockwise 1/2 of the number of turns required to reach the minimum setting and tighten the lock nut. This brings the valve to its median setting, which is optimum for most operating conditions.

13. Test the adjustments by cycling the shear to the closed position six times normally and six times with the shear stalled in the closed position. Monitor the gauge attached to the MAZ carefully. During normal cycling, the gauge should read 400psi (26 bar) or higher. When stalling the shear, gauge pressure should drop to zero.

14. Verify the shift pressure. Have the excavator operator cycle the shear to the fully closed position and carefully monitor the pressure gauge attached to the MAZ test port. Note the pressure reading immediately before the shear stalls. This pressure is the shift pressure required to shift the speed valve out of speed mode. Shift pressure should be 3600 – 3700 PSI. (248- 255 BAR).

15. Turn the excavator off and release all hydraulic pressure to the shear by working the excavator controls in all directions. Be certain to relieve the air pressure in the excavator reservoir. Refer to the excavator operator's manual for proper excavator hydraulic pressure relief procedures. Detach the digital pressure gauge(s) and pressure line(s) from the MBS and /or MAZ test fitting(s). Slowly remove the test fitting(s) from the test port(s) as in step 3 of this procedure and replace the MBS and/or MAZ port plug(s).

16. Restart the excavator. Check for leaks by using a piece of cardboard or other rigid material. Repair all leaks before using the shear. Re-apply the correct torque to all speed valve fasteners including split flanges if found leaking. Use the table on page 8-26 for correct torque values.

17. Speed valve troubleshooting procedures can be found on page 7-10 in the Troubleshooting section in the back of this manual.

SPEED VALVE ADJUSTMENT continued

SPEED VALVE ASSEMBLY TORQUE VALUES: *MSD 1500- 4500 SHEARS*

Proper bolt installation is critical to ensure the safe and efficient operation of the speed valve. Carefully follow the steps below to properly install bolts.

NOTICE

Please note that the parts illustrated below (**Figure 5-47**) and on pages 5-50 through 5-51 are for #513029, which is used in MSD 1500, 2000, 2500, 3000, 4000 and 4500 shears. For MSD 7500 and above, refer to your parts catalog for the speed valve part number and call Stanley LaBounty for torque values. MSD 1000 models do not have speed valves.

1. Always replace bolts and nuts with the same size and class of fastener. Replacement fasteners can be ordered from the Stanley LaBounty Parts Department to ensure the correct part is used. Unless otherwise specified, use class 10.9 metric hex head capscrews, class 10.9 metric flat head capscrews, and class 12.9 metric socket head capscrews.
2. Make sure bolts, nuts and bolt holes are free of dirt, oil, grease and other contaminants. .
3. The torque values in this manual are for use with non-plated fasteners with clean, dry threads. These values are suitable for use with or without thread adhesives, such as Loctite™ products.

SPEED VALVE ASSEMBLY
P/N 513029 USED IN
MSD 1500,2000, 2500,
3000,4000 AND 4500
SHEARS
FIGURE 5-47

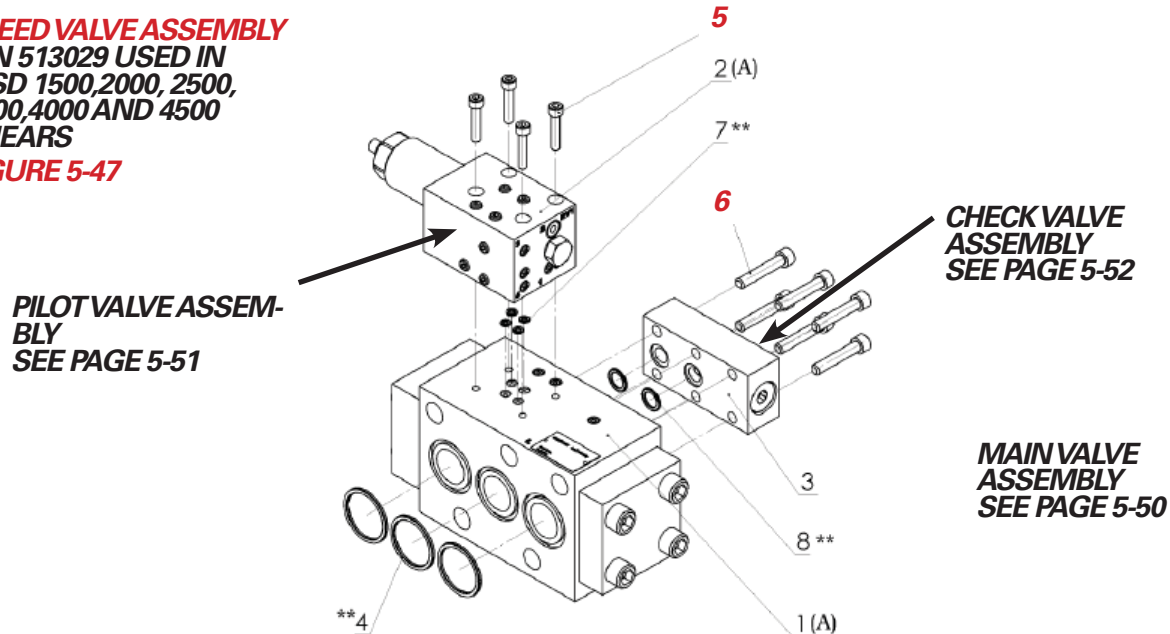

ITEM	PART NUMBER	DESCRIPTION	QTY	TORQUE
5	512210	Socket Head Screw M8X35	4	32 ft lb/43 Nm
6	513133	Socket Head Screw M10X45	6	62 ft lb/84 Nm

MSD SABER SERIES SHEARS

SPEED VALVE ADJUSTMENT continued

SPEED VALVE ASSEMBLY TORQUE VALUES: **MAIN VALVE ASSEMBLY**

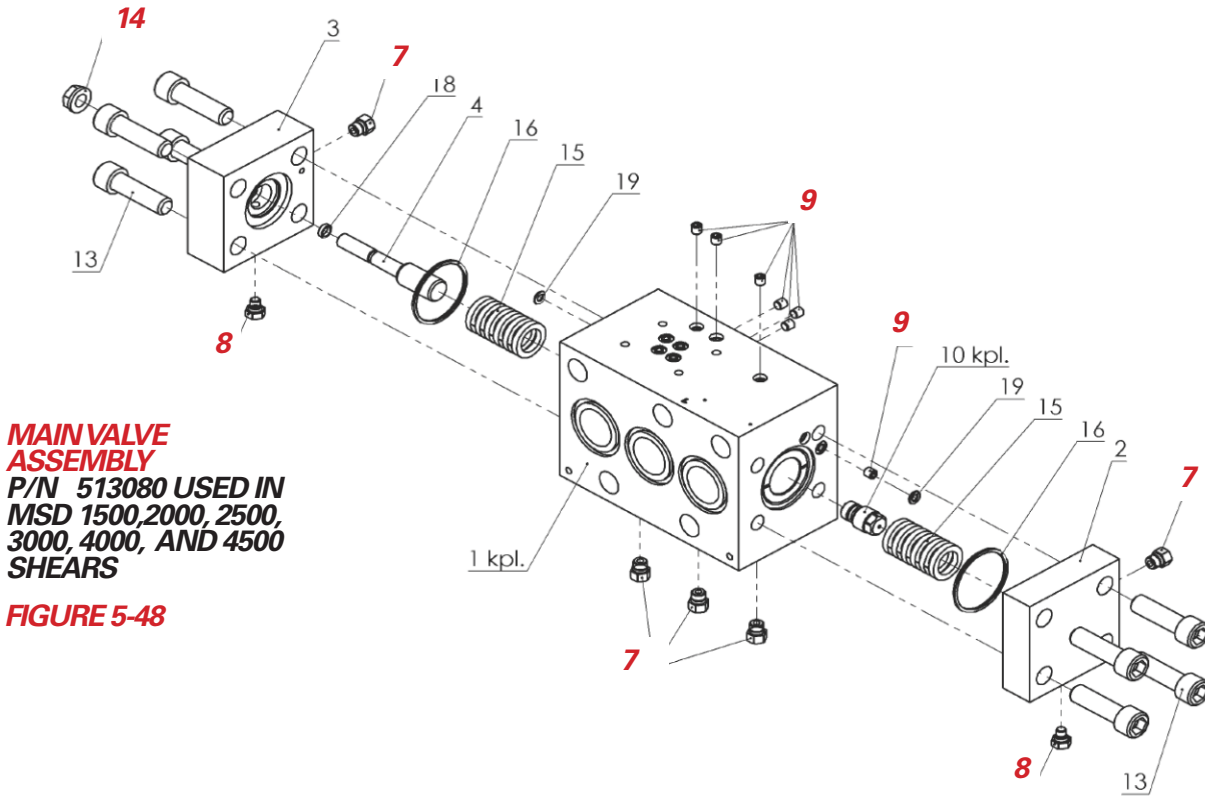

MAIN VALVE ASSEMBLY
P/N 513080 USED IN
MSD 1500, 2000, 2500,
3000, 4000, AND 4500
SHEARS

FIGURE 5-48

ITEM	PART NUMBER	DESCRIPTION	QTY	TORQUE
7	511515	Hex Nut	5	15 ft lbs/20 Nm
8	513086	Hex Nut	2	15 ft lbs/20 Nm
9	513087	Screw Plug (Allen)	7	7 ft lbs/10 Nm
14	511504	Hex Nut	1	22 ft lbs/30 Nm

SPEED VALVE ADJUSTMENT continued

SPEED VALVE ASSEMBLY TORQUE VALUES: **PILOT VALVE ASSEMBLY**

PILOT VALVE
P/N 512288 USED IN
MSD 1500, 2000, 2500,
3000, 4000, AND 4500
SHEARS

FIGURE 5-49

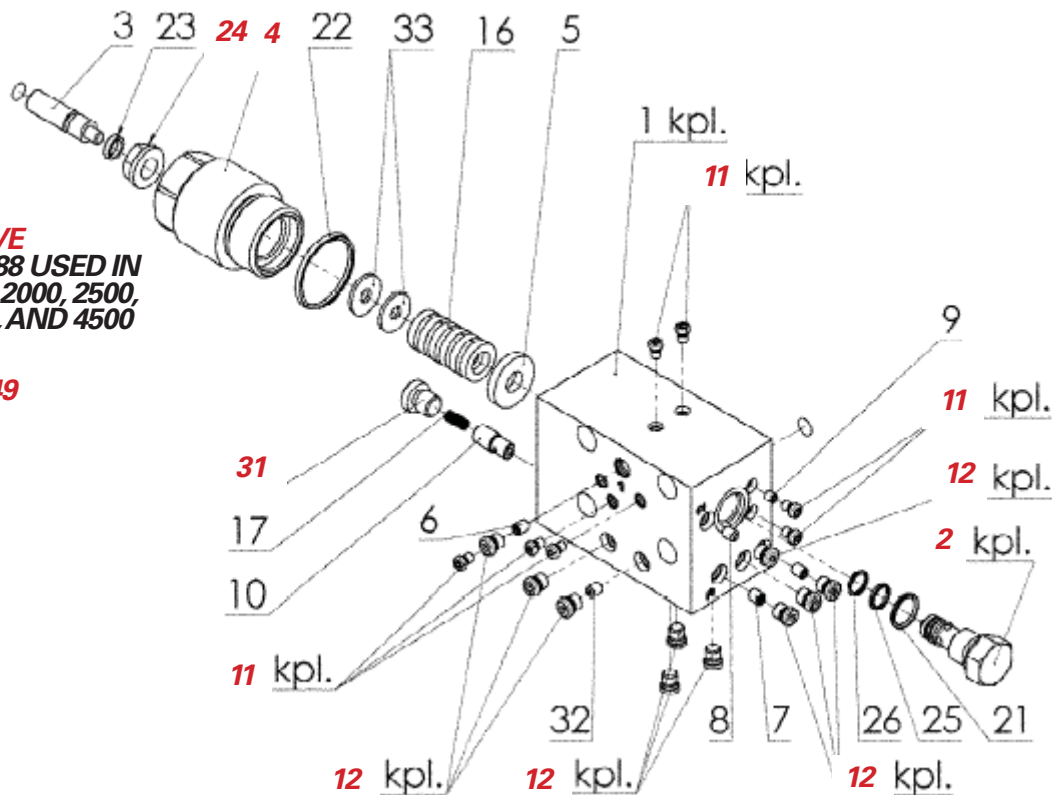

ITEM	PART NUMBER	DESCRIPTION	QTY	TORQUE
2	512317	Valve Seat	1	73 ft lbs/100 Nm
4	512318	Spring Cap	1	162 ft lbs/220 Nm
11	512323	Capscrew	8	1.5 ft lbs/2 Nm
12	511514	Screw Plug	10	7.5 ft lbs/10 Nm
24	511504	Seallock Nut	1	22 ft lbs/30 Nm
31	511563	Screw	1	18 ft lbs/25 Nm

MSD SABER SERIES SHEARS

SPEED VALVE ADJUSTMENT continued

SPEED VALVE ASSEMBLY TORQUE VALUES: **CHECK VALVE ASSEMBLY**

CHECK VALVE ASSEMBLY
P/N 511540 USED IN
MSD 1500, 2000, 2500,
3000, 4000, AND 4500
SHEARS

FIGURE 5-50

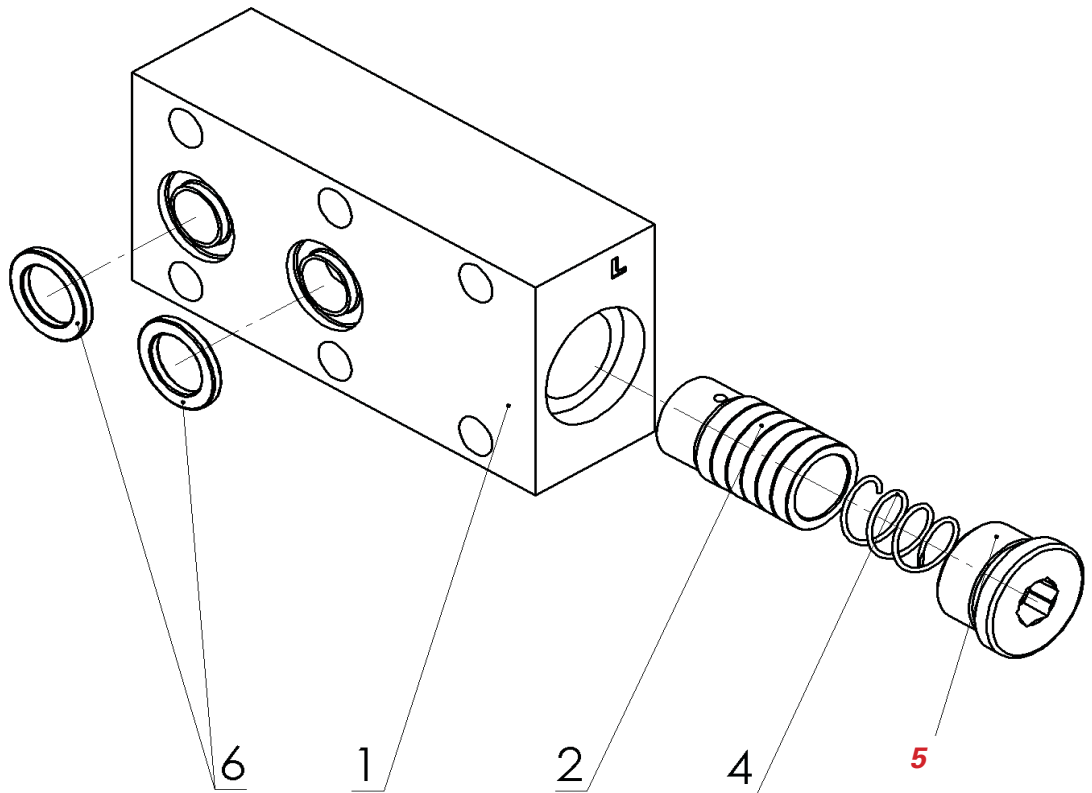

ITEM	PART NUMBER	DESCRIPTION	QTY	TORQUE
5	511579	Screw Plug	1	103 ft lbs/140 Nm

SPEED VALVE ADJUSTMENT continued

SPEED VALVE ASSEMBLY TORQUE VALUES: *MSD 7500, 9500 SHEARS*

Proper bolt installation is critical to ensure the safe and efficient operation of the speed valve. Carefully follow the steps below to properly install bolts.

NOTICE

Please note that the parts illustrated below (**Figure 5-51**) and on pages 5-54 through 5-55 are for speed valve #511461, which is used in MSD 7500 and 9500 shears.

1. Always replace bolts and nuts with the same size and class of fastener. Replacement fasteners can be ordered from the Stanley LaBounty Parts Department to ensure the correct part is used. Unless otherwise specified, use class 10.9 metric hex head capscrews, class 10.9 metric flat head capscrews, and class 12.9 metric socket head capscrews.
2. Make sure bolts, nuts and bolt holes are free of dirt, oil, grease and other contaminants. .
3. The torque values in this manual are for use with non-plated fasteners with clean, dry threads. These values are suitable for use with or without thread adhesives, such as Loctite products.

**SPEED VALVE
ASSEMBLY
P/N 511461 USED IN
MSD 7500 AND 9500
SHEARS**

FIGURE 5-51

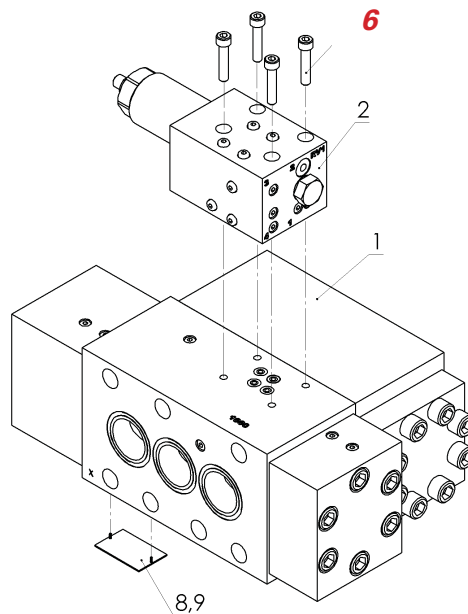

ITEM	PART NUMBER	DESCRIPTION	QTY	TORQUE
6	512210	Socket Head Screw M8X1.25X35	4	31 ft lbs/43 Nm

MSD SABER SERIES SHEARS

SPEED VALVE ADJUSTMENT continued

SPEED VALVE ASSEMBLY TORQUE VALUES: *MSD 7500, 9500 SHEARS*

MAIN BLOCK ASSEMBLY
P/N 512330 USED IN MSD
7500 AND 9500 SHEARS

FIGURE 5-52

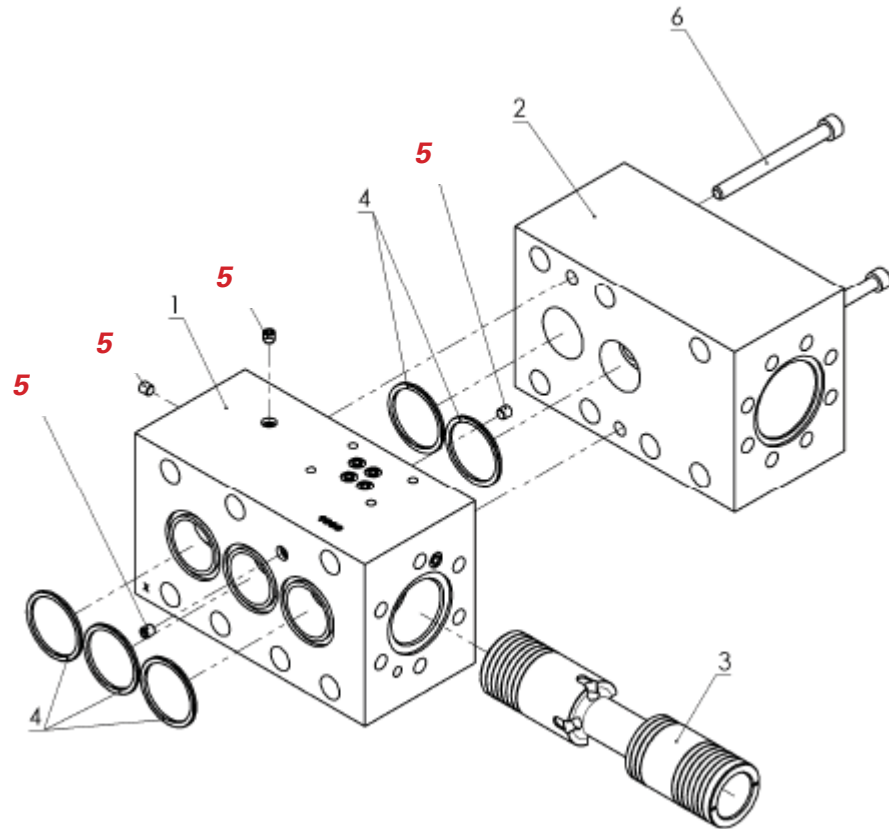

ITEM	PART NUMBER	DESCRIPTION	QTY	TORQUE
5	512338	Screw Plug M8X1	4	7.5 ft lbs/10Nm

MSD SABER SERIES SHEARS

SPEED VALVE ADJUSTMENT continued

SPEED VALVE ASSEMBLY TORQUE VALUES: *MSD 7500, 9500 SHEARS*

REGEN VALVE
P/N 512327 USED
IN MSD 7500 AND
9500 SHEARS

FIGURE 5-53

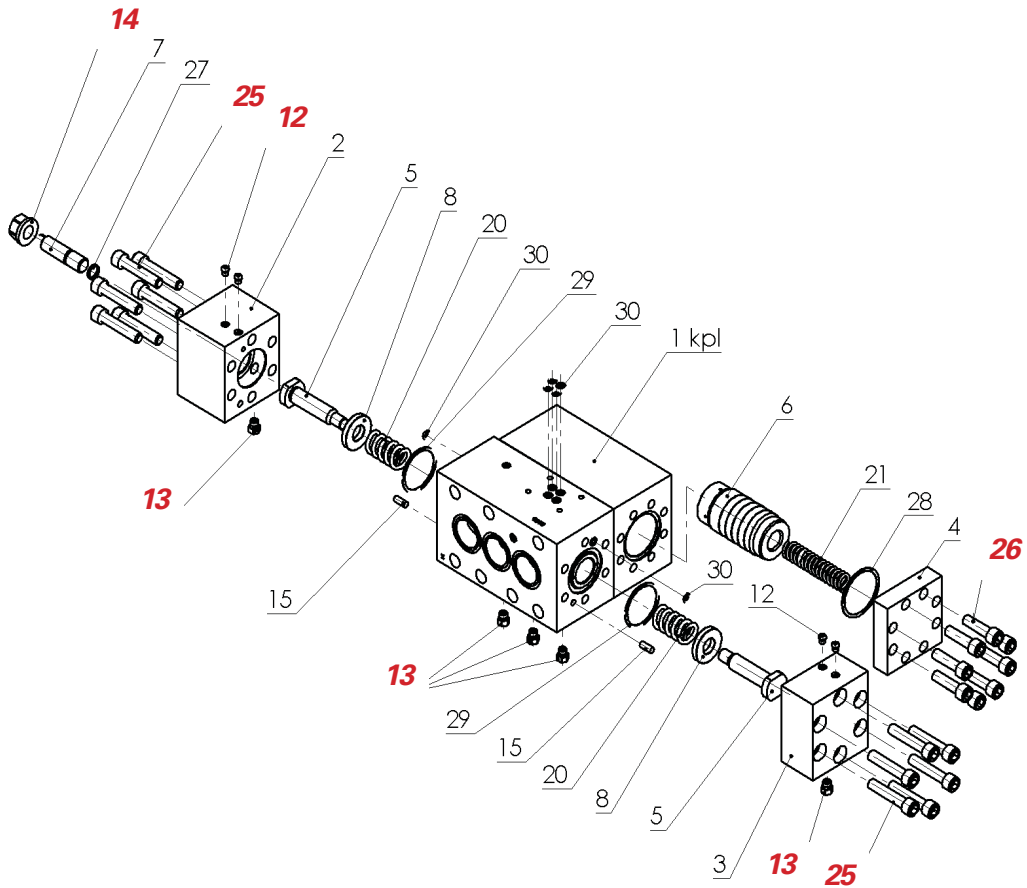

ITEM	PART NUMBER	DESCRIPTION	QTY	TORQUE
12	512338	Screw Plug M8X1	4	7.5 ft lbs/10 Nm
13	511515	Screw Plug 7/16-20	5	15 ft lbs/20 Nm
14	512339	Seallock Nut M20X1.5	1	73 ft lbs/100 Nm
25	512342	Socket Head Capscrew M14X70	12	51 ft lbs/70 Nm
26	512343	Socket Head Capscrew M14X50	8	51 ft lbs/70 Nm

MSD SABER SERIES SHEARS

DECAL AND LABEL MAINTENANCE

Be sure that all safety decals are installed and visible (see **Figure 5-54**). Replacement decals are available from your Stanley LaBounty dealer. Complete label installation kits are available upon request.

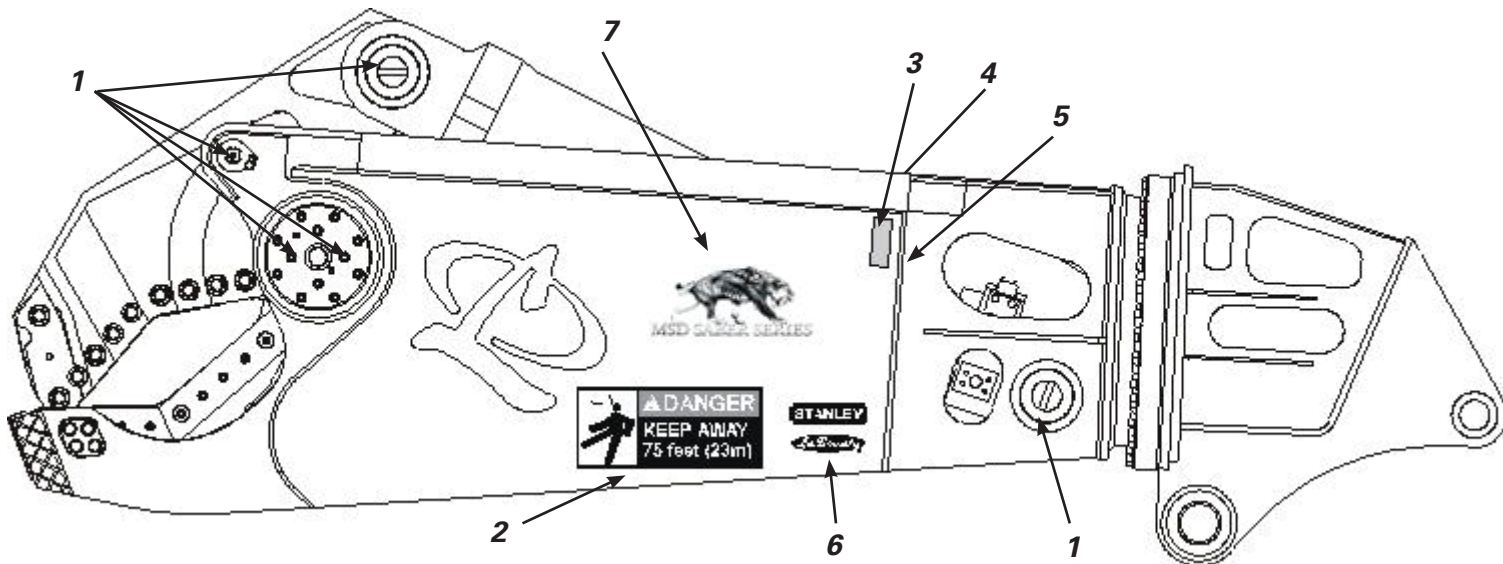

FIGURE 5-54

ITEM	PART NUMBER	DESCRIPTION
1	116388	Grease Decal- one at each grease fitting
2	116389	DANGER Decal- on both sides (Keep 75 feet away during operation)
3	503647	DANGER Decal- on both sides (top and front cab guarding required)
4	511045	Model and Serial Number Plate- on right side only
5	116404	Stanley LaBounty Decals- on both sides toward rear of shear
6	BY MODEL	Stanley LaBounty Decals- on both sides toward rear of shear
7	BY MODEL	Model Decals- on both sides

SECTION 6 ROTATOR MAINTENANCE

Major Components of Typical Rotation Systems	6-2
The Rotator	6-3
Bolt Torque	6-3
Torque Values for Turntable Bolts	6-3
Torque Values for Rotation Assembly Bolts.....	6-3
Planetary Gearbox Lubrication (if equipped)	6-4
Lubricant Change-out Procedure	6-4
Planetary Gearbox Lubricants	6-5
Synthetic Specification	6-5
Gearbox Fill Capacities	6-5
Turntable Bearing	6-6
Turntable Bearing Lubricants.....	6-6
Hydraulic Requirements	6-7
Rotation Control Valve Manifold.....	6-7
Case Drain	6-7
Rotation Control Valve Assembly Schematics and Descriptions.....	6-8
Internal Rotation Control System (if equipped)	6-9
Accumulator Control Valve Assembly (if equipped).....	6-10
Maintenance Intervals for Internal Rotation (if equipped).....	6-11
Accumulator Maintenance.....	6-11
Testing the Accumulator Pre-charge	6-12
Pressure Release.....	6-12
Accumulator Pre-charging.....	6-12
Operating Flow for Internal Rotation	6-13
Operating Pressure for Internal Rotation	6-13

MSD SABER SERIES SHEARS

MAJOR COMPONENTS OF TYPICAL ROTATION SYSTEMS

Typical second member upper head assembly (see **Figure 6-1**, below), with an internal drive rotator, a gearbox and standard rotation.

FIGURE 6-1

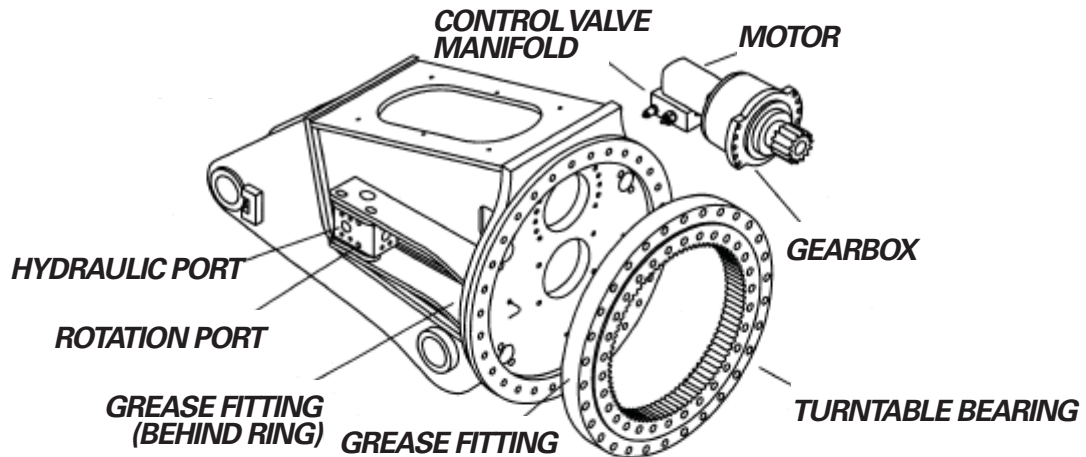

Typical third member upper head assembly (see **Figure 6-2**, below), with an external drive rotator, no gearbox and optional internal rotation control system.

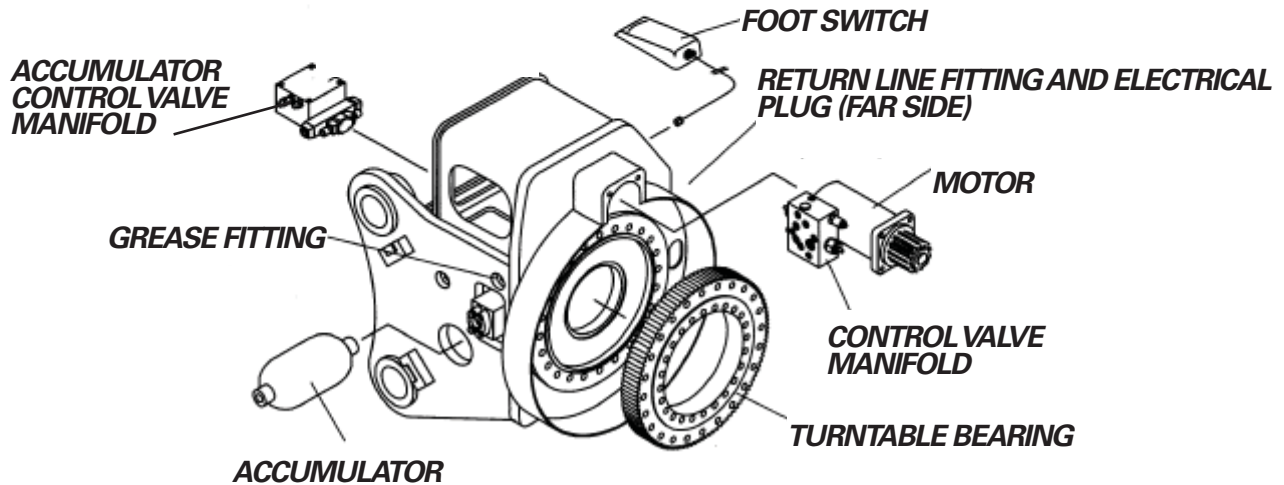

THE ROTATOR

The rotator gives the shear 360 degrees of continuous rotation in both directions for easy, accurate processing at all angles. The hydraulic rotation circuit consists of the hydraulic motor driving a turntable bearing, either directly or through a planetary gearbox. It is necessary to regularly maintain this system to ensure long life and good performance. The maintenance requirements of the rotator are outlined in the following pages.

BOLT TORQUE

The bolts connecting the turntable bearing are a critical structural area. The bolts must be inspected after the initial eight hours of operation and weekly thereafter. Damaged fasteners must always be replaced with the same size and grade of fastener. If bolts are found to be loose after operation, they should never be retorqued more than one time before they are replaced. Please contact the Stanley LaBounty Service Department for specific information about replacement.

TORQUE VALUES FOR TURNABLE BOLTS

SIZE	CLASS	FTLBS	N-M
M20	10.9	435	590
M20	12.9	523	710
M24	10.9	752	1020
M24	12.9	900	1220
M30	10.9	1511	2049
M30	12.9	1800	2450
1.00"	L-9	900	1220
1.50"	ZN-L-9	2600	3520

TORQUE VALUES FOR ROTATION ASSEMBLY BOLTS

SIZE	CLASS	FTLBS	N-M
M10	12.9	49	67
M12	10.9	71	96
M16	10.9	173	235
M20	10.9	335	454
.38"	Gr.8	63	85
.50"	Gr.8	106	209
.75"	Gr.8	380	515

⚠ WARNING

Always replace bolts and nuts with the same size and class fastener. Inferior fasteners can fail and cause injury or death and damage to the equipment.

NOTICE

- Use of the rotation feature for any other purpose may damage the rotation components and may void the shear warranty.
- It may be necessary to rotate the shear to access all the bolts connecting the shear, turntable bearing and rotating head.
- Be sure to use the proper torque value for the size, class, and type of bolt.

MSD SABER SERIES SHEARS

PLANETARY GEARBOX LUBRICATION if equipped

The planetary gearbox is used if changes in gear ratios are required between the hydraulic motor and turntable bearing to rotate the shear. Correct lubricant and change-out procedures are critical to maintain dependable gearbox operation. The Planetary Gearbox Lubricants chart on the following page specifies correct lubricants for various operating temperature.

The gearbox lubricant must be changed after the first 50 hours of operation to remove metal filings from the gearbox break-in period. Thereafter, refer to the following change-out schedule:

GRADE	TIME
SAE 80W-90	500 hours or one year
Synthetic ISO 150 @ 104°F	1000 hours or two years
Synthetic ISO 460 @ 104°F	1000 hours or two years

Recommended inspection of the gearbox fluid level is every 250 hours or six months.

- Cold weather lubrication is critical. If the temperature is below 5°F (-14°C), change out lubricant to synthetic specification.
- Slow rotation of the shear is recommended with all grades of lubricant at temperatures below 20°F (-7°C) to warm up the rotation system prior to working the shear.
- All rotating shears leaving the factory have synthetic ISO 150 @ 104°F grade lubricant in the gearbox.

LUBRICATION CHANGE-OUT PROCEDURE

1. Position the shear at a comfortable working height and in a position where gearbox is near level (gearbox rotation axis should be horizontal).
2. Remove the upper head to access cover.
3. Place a lubricant catch basin below the drain plug capable of hold more than 2 quarts.
4. Remove the drain plug (bottom) and the visible top plug. These plugs are magnetic and will attract metal filings from inside the gearbox. These filings should be removed from the plugs before reinstalling.
5. Reinstall the drain plug once the gearbox is fully drained.
6. Add the applicable gearbox lubricant through top plug hole. Refer to the chart on the following page for proper fill capacity for your gearbox.
7. Remove lubricant catch basin.
8. Reinstall top plug and gearbox access cover.



**Support the shear with blocking or cribbing during this procedure.
Be sure the excavator is shut off.**

PLANETARY GEARBOX LUBRICANTS

OPERATING AMBIENT TEMPERATURE RANGE	RECOMMENDED GRADES
5°F to 120°F (-14°C to 49°C)	SAE 80W- 90
-50°F to 120°F (-46°C to 49°C)	Synthetic ISO 150 @ 104°F
-25°F to 180°F (-32°C to 82°C)	Synthetic ISO 460 @ 104°F

APPROVED SOURCE/GRADE	GRADE
Manufacturers of approved SAE lubricants	SAE 80W- 90
Mobile Oil Corp- Mobilube SHC 75W-90	Synthetic ISO 150 @ 104°F
Mobile Oil Corp- Mobilube SHC 80W-140	Synthetic ISO 460 @ 104°F

SYNTHETIC SPECIFICATION

MOBILUBE SHC	75W- 90	80W- 140
Product Number	51100-6	51101-4
SAE Number	75W- 90	80W- 140
Gravity API	29.8	30.2
Flash PT °C (°F), Min.	204 (400)	218 (425)
Flash PT °C (°F), Max.	-48 (-55)	-42 (-45)
Viscosity		
cP @ - 40°C	109,000	---
cP @ -26°C	---	80,000
cST @ 40°C	117	312
cST @ 100°C	15.5	31.3
Viscosity Index	139	139

GEARBOX FILL CAPACITIES

PART NUMBER	FILL CAPACITY	MODEL NUMBER
510783	17 fluid ounces (0.5 liter)	MSD 1500R, MSD2000R
511491	68 fluid ounces (2.0 liters)	MSD 2500R
511493	68 fluid ounces (2.0 liters)	MSD3000R, MSD4500R
511373	68 fluid ounces (2.0 liters)	MSD7500R, MSD9500R
512565	22 fluid ounces (0.66 liter)	MSD1500R, MSD2000R

MSD SABER SERIES SHEARS

TURNTABLE BEARING

LUBRICATION FREQUENCY

Equipment operating frequently in extreme environments should be lubricated at least every eight hours. If the old grease is noted to be in good condition and free of contamination, the interval may be extended. Conversely, if the old grease is contaminated or deteriorated, the interval should be shortened. Rotating shears in storage should be lubricated at least every six months.

LUBRICATION PROCEDURES

Bearings are equipped with one to four grease fittings, depending upon the model. The grease fittings will be located either on the outside of the bearing (if it is an internal drive rotator) or on the upper head side plate (external drive). To lubricate the bearing, grease a fitting and then stand clear to rotate the shear. This will uniformly distribute the grease and effectively flush out the old grease and contaminants. Grease the same fitting again after rotating before moving on to the next fitting. Grease each fitting a total of eight pumps of the grease gun or until grease escapes through the bearing seals.

⚠ WARNING

Stand clear of the shear while rotating. Grease a fitting and then stand clear to rotate the bearing to distribute the grease. DO NOT attempt to grease the bearing while the shear is rotating or severe injury could occur.

TURNTABLE BEARING LUBRICANTS

For normal operating conditions, periodic lubrication with lithium Grade 2 extreme pressure grease is recommended. For operation below 32°F (0°C), Grade 0 is recommended. The following table lists typical lubricants for turntable bearings (comparable lubricants by other manufacturers may also be used):

APPROVED SOURCE	TRADE NAME	OPERATION BELOW 32°F	OPERATION ABOVE 32°F
Amoco	Rycon	EPO	EP2
Chevron	Dura Lith	EPO	EP2
Exxon	Lidok	EPO	EP2
Mobil	Mobilux	EPO	EP2
Shell	Alvania	EPRO	EP2
Sohio	Bearing Guard	LTO	2
Sun	Prestige	740EP	742EP
Texaco	Multifak	EPO	EP2
Union	Unoba	EPO	EP2

HYDRAULIC REQUIREMENTS

The rotating shear requires an auxiliary hydraulic circuit in order to operate the rotator. This circuit will need to be a medium pressure (2000- 2500 PSI/138- 172 BAR), low flow (8- 10 GPM/30- 39 LPM) hydraulic circuit. There are minimum and maximum pressure and flow requirements that may vary depending upon the shear model. These requirements are listed in the Hydraulic Installation Requirements sheet in the Parts Catalog for the shear. The rotation control manifold may vary depending upon the type of the rotation system and the particular requirements for the rotation circuit. Adjustment procedures for the rotation control valve are given on the following pages.

ROTATION CONTROL VALVE MANIFOLD

One of two rotation control valves is installed on the shear depending upon the model. The rotation control valve manifold provides overload protection and a load control system for the rotator with two crossover relief valves and two brake valves. The crossover relief valve and brake valves have been preset at the factory and require no adjustment. Do not tamper with these valves. If a malfunction is suspected due to a lack of performance in the rotator, a pressure check should be performed. Diagnostic fittings (which require a Parker PD Series coupler or gauge) are installed in the manifold to provide a means of checking pressure. Contact the Stanley LaBounty Service Department for the proper procedure for performing this check.

CASE DRAIN

A case drain is required because back pressure can develop in the hydraulic motor case as a result of metering flow out of the motor. Depending upon the shear model, this port will either be a bulkhead in the upper head side plate or will be located in the hydraulic port block. A 1/2" hydraulic line should be connected to this port and routed back directly to the tank via a return-line filter or a filter of its own. The maximum allowable back pressure in this line should not exceed 300 PSI.

NOTICE

The case drain line must be connected to prevent failure to the case or motor seals.

MSD SABER SERIES SHEARS

ROTATION CONTROL VALVE ASSEMBLY SCHEMATICS AND DESCRIPTIONS

Please refer to the Parts Catalog to identify the control valve assembly in your specific attachment.

ROTATION CONTROL VALVE USED ON MODELS MSD 1500R AND MSD 2000R

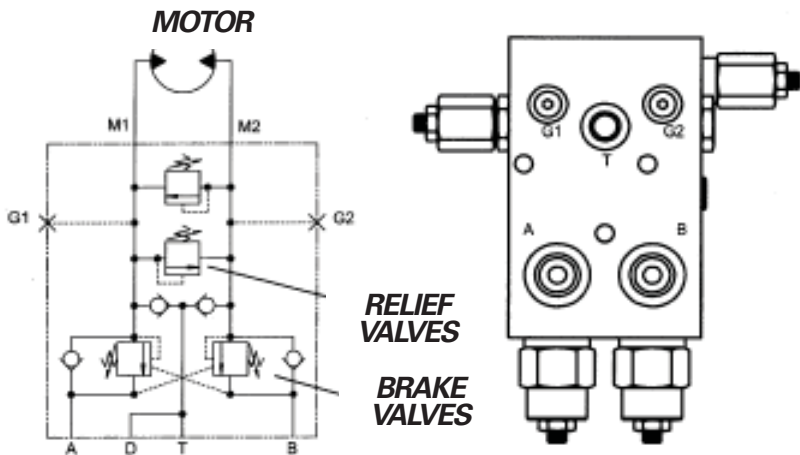

WORK PORTS (A & B)
SAE #8 O-Ring Boss Ports

GAUGE PORTS (G1 & G2)
SAE #4 O-Ring Boss Ports

FIGURE 6-3

ROTATION CONTROL VALVE USED ON MODELS MSD 2500R, 3000R, 4000R, 4500R

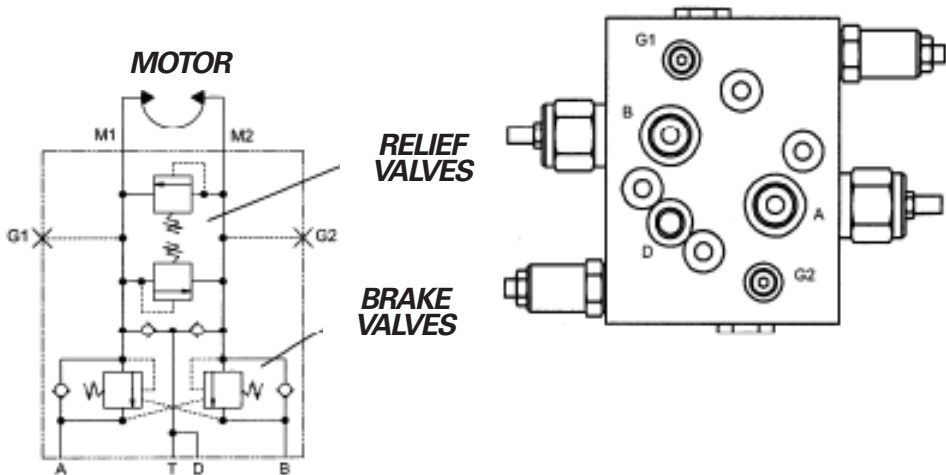

WORK PORTS (A & B)
SAE #10 O-Ring Boss Ports

GAUGE PORTS (G1 & G2)
SAE #4 O-Ring Boss Ports

FIGURE 6-4

INTERNAL ROTATION CONTROL SYSTEM if equipped

The optional Internal Rotation Control System is designed to provide a medium pressure, low-flow hydraulic power source for rotating the shear. The system is factory installed inside the rotating head of the shear and consists of the following major components: Accumulator, accumulator control valve assembly, and foot switch.

The circuit taps into the shear's hydraulic supply manifolds to draw only enough fluid to charge the accumulator. This fluid is held in reserve until the control valve is actuated, which sends the fluid to the rotation motor to drive the rotator. The diagram below, **Figure 6-5**, represents a typical Internal Rotation Control System. The layout of the system that has been installed in your shear may vary slightly, but the main components among shear models are generally the same.

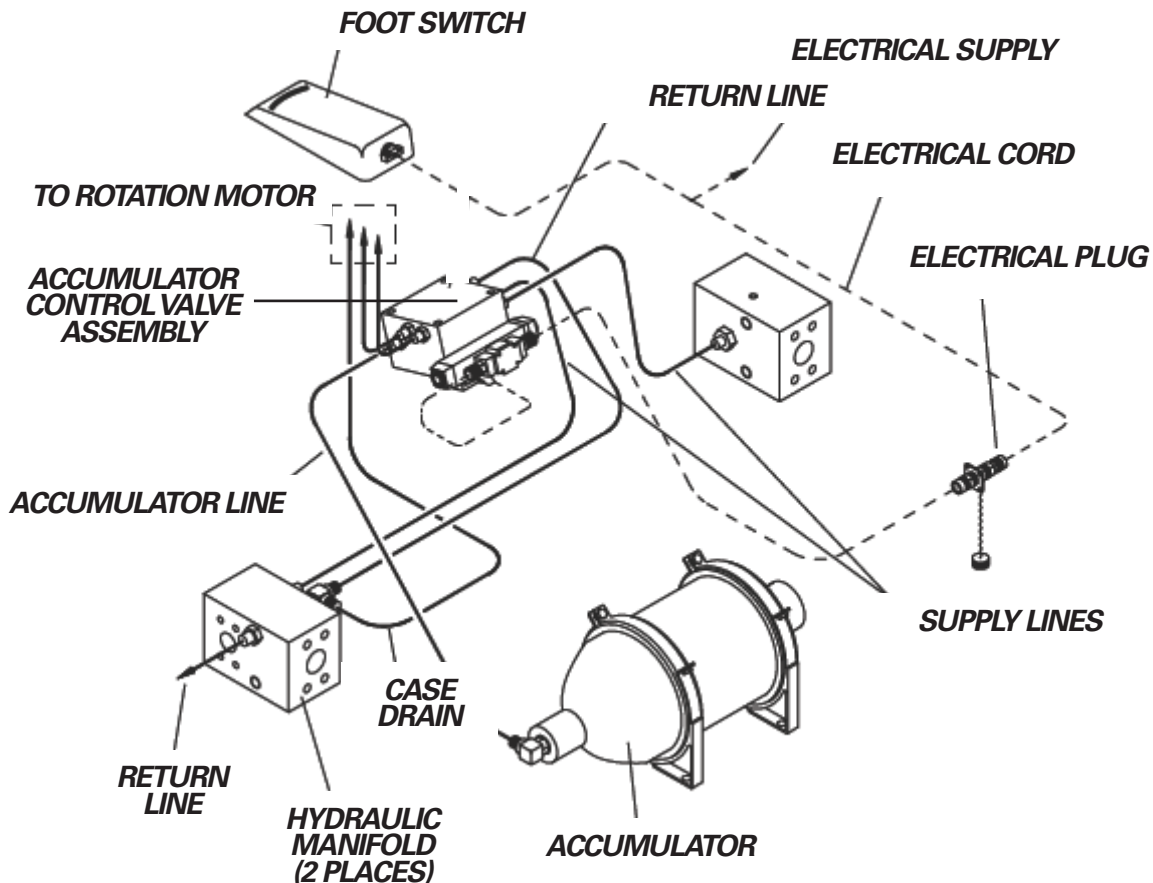

FIGURE 6-5

MSD SABER SERIES SHEARS

ACCUMULATOR CONTROL VALVE ASSEMBLY if equipped

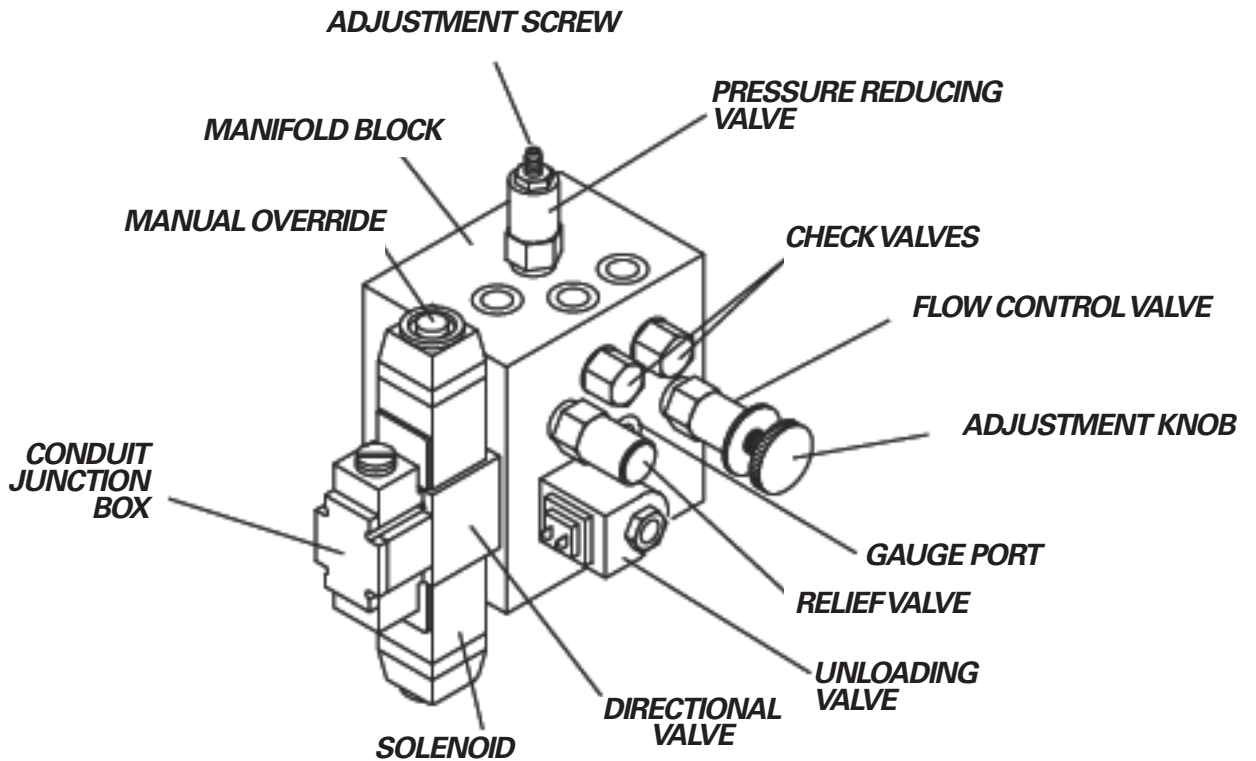

FIGURE 6-6

MAINTENANCE INTERVALS FOR INTERNAL ROTATION if equipped

A program of regular service should be established for the shear, including maintenance of the Internal Rotation Control System. Use the base machine hour meter to determine service intervals.

The 8-Hour Inspection Checklist in this manual includes the rotation system and should be used daily to check for wear, loose hose connections or components, and other signs of potential failure.

There are three maintenance items within the Internal Rotation Control System that should be checked every six months or 1000 hours of operation:

1. Accumulator Precharge Pressure
2. Operating Flow
3. Operating Pressure

Keeping these three items adjusted to the specifications provided in this section will ensure that the rotator is operating efficiently and safely.

ACCUMULATOR MAINTENANCE

There is a bladder inside the accumulator that is precharged with nitrogen gas when the shear leaves the factory. When the accumulator is filled with hydraulic fluid, this nitrogen bladder compresses and pressurizes the accumulator. When the rotator function is operated, the pressurized accumulator sends the fluid to the hydraulic motor to rotate the shear. If the accumulator is not properly precharged, it directly affects the performance of the rotator. For this reason it is necessary to check and maintain the proper accumulator precharge.

Prior to testing or precharging, lower the shear to the ground and support it properly in a position that will give you the best possible access to the accumulator. It is necessary to drain the accumulator of hydraulic fluid to accurately measure its precharge. This is done by shutting off the base machine, which will cause the unloading valve to drain the accumulator. To work on the accumulator, the protective cap and cap nut must be removed. The O-ring must not be removed. Install a Schrader valve into the accumulator if one does not already exist there. Contact the LaBounty Service Department if the Schrader valve hasn't been installed on your accumulator. Attach an accumulator charge and test unit so the gauge can be easily read. The location of some accumulators may require a special adapter for access to the gas valve.

MSD SABER SERIES SHEARS

TESTING THE ACCUMULATOR PRECHARGE

Once the test unit is attached, make sure the relief valve is closed and then turn the spindle. When the pointer of the gauge begins to move, turn the spindle one more full turn. The gauge should now show the amount of accumulator precharge pressure. The proper amount of accumulator precharge is 1100- 1200 PSI (76-83 BAR). If the gauge is showing something other than the proper precharge, it will be necessary to either release pressure or further precharge the accumulator.

PRESSURE RELEASE

To release pressure, slowly open the relief valve (see **Figure 6-7**). This will release nitrogen into the atmosphere. Close the valve when the desired pressure is reached.

ACCUMULATOR PRECHARGE

⚠ WARNING

Never use oxygen or shop air to precharge the accumulator. This could cause an explosion! Use only dry nitrogen for precharging accumulators.

1. Connect a charging hose to the shut-off valve of a commercially available nitrogen supply bottle. Connect the other end of the charging hose to the nipple of the charging unit. With the spindle open, slowly open the valve on the nitrogen supply bottle to release nitrogen into the accumulator until the desired level is reached.
2. Allow five minutes for the nitrogen temperature to adjust. Recheck and repeat process until proper pressure (1100 PSI/76 BAR) is reached.
3. When the required precharge pressure is reached, unscrew the spindle valve so the gas valve on the accumulator closes. Check the valve on the accumulator for leaks by using sealing spray or soapy water. Replace cap nut and protective cap.

⚠ WARNING

If the gas pressure in the nitrogen supply bottle is higher than the maximum operating pressure of the accumulator, a gas pressure reducing valve or regulator must be fitted.

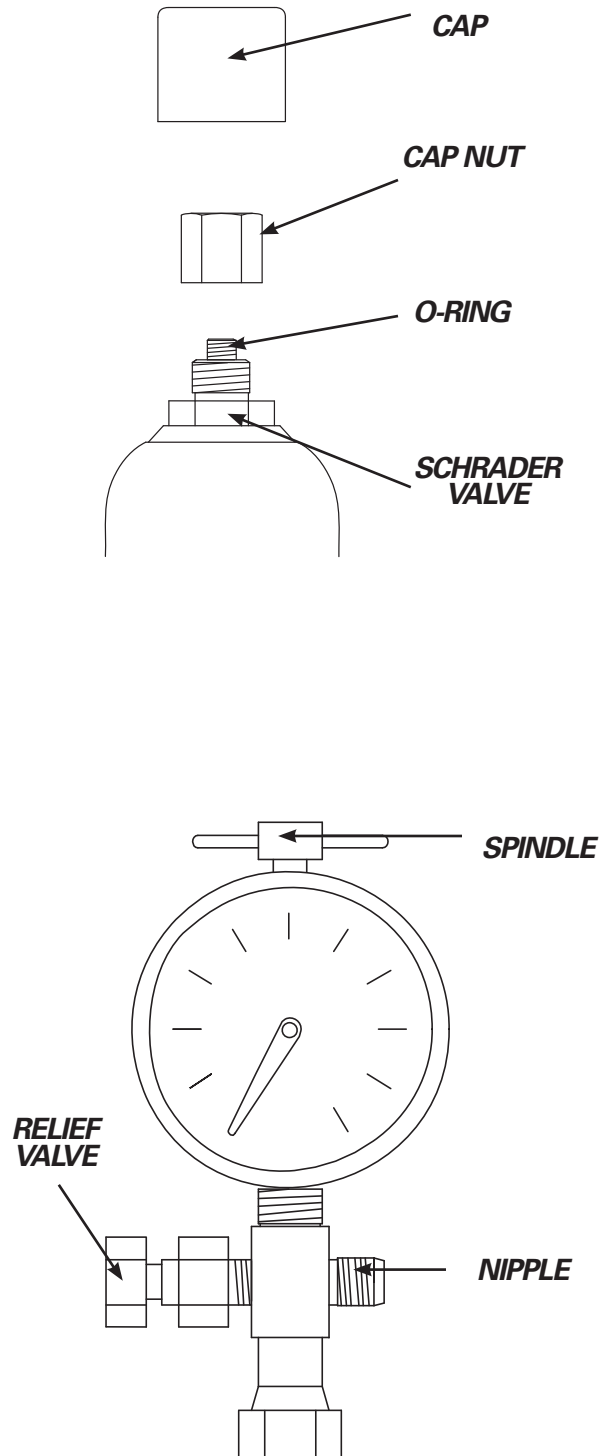

FIGURE 6-7

OPERATING FLOW FOR INTERNAL ROTATION

The operating flow of the Internal Rotation Control System directly affects the speed at which the shear will rotate. Two people are necessary to check the operating flow of the Internal Rotation Control System. Install a flow meter between the A and B ports on the Accumulator Control Valve Assembly (these are the works ports for the valve). The direction in which the flow meter is installed does not matter. Operate the direction valve by using the foot switch in the operator's cab and check the flow meter reading. LaBounty recommends that a flow of 6- 10 GPM (23- 38 LPM) be maintained.

It may be desirable for you to adjust the flow within the recommended range to increase or decrease the speed of rotation. To do this, the lock nut on the flow control valve first must be loosened. Then turn the flow control adjustment knob until you reach the desired flow. Make sure to retighten the lock nut when the adjustments are completed.

NOTICE

Do not exceed 10 GPM (38 LPM) or damage to the rotation system may result.

OPERATING PRESSURE FOR INTERNAL ROTATION

To check the operating pressure of the Internal Rotation Control System, the plug in the gauge port of the Control Valve Assembly (marked with a "G") must be replaced with an adapter fitting that is compatible with the pressure gauge you are using. The gauge port is a 7/16" - 20 SAE O-Ring Boss threaded port.

Once the pressure gauge is hooked up to the gauge port, have the operator start up the base machine. Cycle the shear until it is either fully open or fully closed and continue to operate this hydraulic function even after the jaws have bottomed out. This will cause the base machine operating pressure to rise and will enable you to check the operating pressure of the rotation system.

To adjust the operating pressure, first loosen the lock nut on the Pressure Reducing Valve (see **Figure 6-8**). Then slowly turn the adjustment screw in the end of this valve to adjust the pressure until it falls within the specified range. Retighten the lock nut when you have completed these adjustments.

NOTICE

The operating pressure of the Internal Rotation Control System should be 2000- 2500 PSI (138- 172 BAR). If your pressure does not fall within this range, it will be necessary to adjust it or the Rotation system may be damaged.

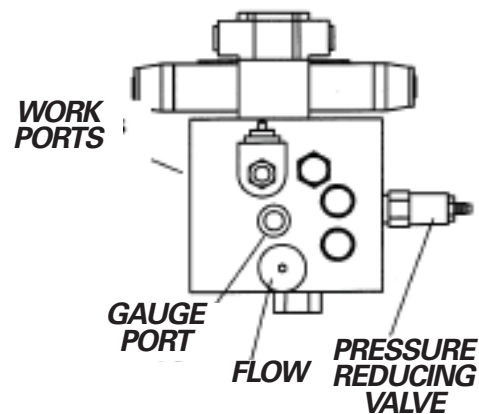

FIGURE 6-8

MSD SABER SERIES SHEARS

SECTION 7 TROUBLESHOOTING

Cutting Performance Troubleshooting Guide 7-2
Rotation Circuit Troubleshooting Guide..... 7-5
Internal Rotation Control System Troubleshooting Guide (if equipped)..... 7-7
Speed Valve Troubleshooting Guide 7-10



MSD SABER SERIES SHEARS

CUTTING PERFORMANCE TROUBLESHOOTING GUIDE

The information contained in this guide provides for troubleshooting the LaBounty shear only. Any references to the excavator will be made only to give some guidance as to where a problem may exist. Any specific maintenance and troubleshooting information will need to be provided by the Original Equipment Manufacturer of the excavator or the authorized dealer. If a question arises regarding the operation or maintenance of the shear, contact your LaBounty dealer for the proper instruction.

SYMPTOM	PROBABLE CAUSE	REMEDY
1. Upper shear jaw will not move	a. No hydraulic fluid to shear cylinder b. Broken hydraulic swivel c. Shear is jammed	i. Check hydraulic flow at hydraulic manifold block on shear. ii. Check excavator hydraulic circuit. i. Replace swivel and flush hydraulic circuit (if rotator). i. Consult the LaBounty Customer Service department for instructions.
2. Cutting speed is extremely slow	a. Excavator oil supply (flow) is too low b. Hydraulic cylinder seal bypass c. Hydraulic lines are kinked d. Hydraulic swivel seal bypass	i. Check flow to shear and compare with recommended flow (see hydraulic letter). ii. Check for excessive back pressure. iii. Check excavator hydraulic system. i. Check for cylinder seal bypass; replace seals if necessary. i. Check hydraulic lines; replace any damaged lines. i. Check for seal bypass (consult your dealer service department for instructions). Install new seal kit if necessary.
3. Jaws move too rapidly	a. Hydraulic flow to attachment is excessively high	i. Reduce flow to the attachment. NOTE The attachment may be damaged if flow exceeds the recommended GPM.
4. Upper shear jaw drifts	a. Excavator hydraulic valve open or closed is open center type b. Excavator control valve is faulty c. Hydraulic cylinder seal bypass d. Hydraulic swivel bypass (if rotator)	i. Check hydraulic circuit to verify. Replace with closed center spool type. i. Refer to excavator maintenance manual for correct procedures. - check for sticky spool - check for circuit relief valve bypass - check for spool seal bypass i. Check for seal bypass; replace seals if necessary. i. Check swivel for bypass; replace seals if necessary.

CUTTING PERFORMANCE TROUBLESHOOTING GUIDE

continued

SYMPTOM	PROBABLE CAUSE	REMEDY
5. Does not shear material	<p>a. Wrong type of material for shear size</p> <p>b. Worn blades</p> <p>c. Excessive blade gap</p> <p>d. Hydraulic lines are kinked</p> <p>e. Hydraulic pressure at shear is too low</p> <p>f. Excessive back pressure</p> <p>g. Cylinder seal bypass</p>	<p>i. Check material size and type then consult your LaBounty dealer or factory</p> <p>i. Rotate blades per maintenance manual instructions</p> <p>i. Check blade gap and shim (refer to shimming procedure) ii. Replace with LaBounty approved blades iii. Replace thrust washers</p> <p style="text-align: center;">NOTE Always consult your LaBounty dealer before entering the main pivot group.</p> <p>i. Check the lines feeding oil to the shear, replace any kinked lines.</p> <p>i. Compare with excavator's specific operating pressure ii. Check the shear cylinder iii. Check the shear rotation manifold, if equipped iv. Check the excavator hydraulic system</p> <p>i. Check for kinked lines on the return side (rod) ii. Check the size of the lines iii. Check for restrictor valve in the circuit iv. Check the return filter, replace if necessary v. Check the control valve</p> <p>i. Replace seal kit and inspect for any necessary repairs to the cylinder</p>
6. Material jams	<p>a. Excessive blade gap</p> <p>b. Worn Saber tip</p> <p>c. Dull blades</p> <p>d. Blades not within LaBounty specifications</p>	<p>i. Add blade shims (refer to blade shimming in jaws procedure) ii. Replace worn blades</p> <p>i. Either rotate or replace</p> <p>i. Rotate blades ii. Replace, if all four edges are dull, with LaBounty approved blades</p> <p>i. Replace blades with LaBounty approved blades.</p>

MSD SABER SERIES SHEARS

CUTTING PERFORMANCE TROUBLESHOOTING GUIDE continued

IMPORTANT NOTE: If the shear is jammed with material caught in the jaws and will not open, lubricate the blades with penetrating oil and attempt to cycle the shear open. If the jam persists, remove the lower blades and guide blades fasteners and open the shear. This will allow the blades to come out of their seats thus freeing the jam. Upon jam removal, perform the proper maintenance on the shear as detailed in this manual.

SYMPTOM	PROBABLE CAUSE	REMEDY
6. Does not shear material, continued	<p>e. Excessive guide blade/front Saber Tip Wear</p> <p>f. Worn cross blade</p>	<p>i. Add guide blade shims (refer to guide gap blade shimming procedure)</p> <p>ii. Rotate guide blade or replace when both sides are worn</p> <p>iii. Replace Saber Tip</p> <p>i. Rotate or replace the cross blade</p>
7. Blade gap is uneven	<p>a. Non-LaBounty blades being used</p> <p>b. Debris in blade seat behind blades or adjustment plates from blade seats</p> <p>c. Inconsistent amount of blade shims between primary and secondary blades</p> <p>d. Upper shear is bent</p>	<p>i. Replace with LaBounty approved blades</p> <p>i. Remove blades and adjustment plates and clear all debris</p> <p style="text-align: center;">NOTE Adjustment plates must be replaced exactly as they were removed.</p> <p>i. Reshim blades for consistency (refer to blade shimming procedure)</p> <p>i. Consult the LaBounty Customer Service department for repair.</p>
8. Individual hydraulic function is slow	<p>a. Pilot control hoses pinched</p> <p>b. Jumpline or connections</p> <p>c. Excavator hydraulic malfunction</p> <p>d. Circuit relief valve for the function is set low or malfunctioning</p>	<p>i. Inspect and correct</p> <p>i. Inspect and correct leaking</p> <p>i. Check excavator hydraulic system</p> <p>i. See your excavator dealer</p>

ROTATION CIRCUIT TROUBLESHOOTING GUIDE

The information contained in this guide provides for troubleshooting the LaBounty shear only. Any reference to the excavator will be made only to give some guidance as to where a problem may exist. Any specific maintenance and troubleshooting information will need to be provided by the original equipment manufacturer of the excavator or the authorized dealer.

SYMPTOM	PROBABLE CAUSE	REMEDY
1. Shear will not rotate	<ul style="list-style-type: none"> a. Operating flow is too low b. Crossover relief valve is bypassing oil c. Operating pressure is too low d. System hydraulic fluid e. Broken output shaft drive f. Internal leakage in manifold block on motor g. Excessive wear on motor rotating components h. Speed reducer gearbox shaft broken i. Internal leakage in valve supplying oil j. Valve supplying hydraulic flow is faulty 	<ul style="list-style-type: none"> i. Flow control valve needs adjustment ii. Check supply flow i. Replace crossover relief valve i. Check crossover relief valve ii. Check supply pressure i. Check base machine hydraulic system temperature excessively high i. Replace or rebuild the hydraulic motor i. Replace manifold block on motor ii. Check cartridge valve seals for damage i. Replace or reseal the hydraulic motor ii. To check this remove the case drain line and measure the amount of flow out of the case i. Rebuild or replace the gearbox i. Check base machine hydraulic system i. Check base machine hydraulic system
2. Rotation is excessively slow	<ul style="list-style-type: none"> a. Operating pressure is too low b. Crossover relief valve bypassing oil c. Operating flow is too low 	<ul style="list-style-type: none"> i. Replace crossover relief valve to increase the pressure i. Replace crossover relief valve i. Adjust flow control to increase flow to rotation group

MSD SABER SERIES SHEARS

ROTATION CIRCUIT TROUBLESHOOTING GUIDE

continued

SYMPTOM	PROBABLE CAUSE	REMEDY
2. Rotation is excessively slow, continued	<p>d. Internal leakage in manifold block on motor</p> <p>e. Motor is worn out</p> <p>f. Supply pressure too low</p> <p>g. Supply flow too low</p> <p>h. Internal leakage in valve</p> <p>i. Valve supplying hydraulic fluid is not working</p>	<p>i. Replace manifold block on motor</p> <p>ii. Check cartridge valve seals for damage</p> <p>i. Rebuild or replace the motor</p> <p>i. Check base machine hydraulic system</p> <p>i. Check base machine hydraulic system</p> <p>i. Check base machine hydraulic system</p> <p>i. Check base machine hydraulic system</p>
3. Rotation speed excessively high	<p>a. Operating flow too high</p> <p>b. Supply flow too high</p>	<p>i. Adjust flow control to decrease flow to rotation group</p> <p>i. Check base machine hydraulic system</p>
4. Rotation erratic	<p>a. Crossover relieve valve cartridge is faulty</p> <p>b. Flow control valve cartridge is faulty</p> <p>c. Valve spool sticking in valve supplying oil</p> <p>d. Faulty electrical signal at control valve (if electrically controlled)</p> <p>e. Planetary gearbox binding</p> <p>f. Motor binding in planetary gearbox</p> <p>g. Fault circuit relief valve</p> <p>h. Varying pilot pressure to control valve</p>	<p>i. Replace crossover relief valve</p> <p>i. Replace flow control valve</p> <p>i. Check base machine hydraulic system</p> <p>i. Replace electric solenoid</p> <p>i. Rebuild or replace gearbox</p> <p>i. Disassemble motor from gearbox and inspect to determine cause of binding</p> <p>i. Check base machine hydraulic system</p> <p>i. Check base machine hydraulic system</p>
5. Rotation drifts	<p>a. Control valve ports are open to tank with spool in neutral position</p> <p>b. Excessive leakage in control valve spool</p> <p>c. Crossover relief valve is leaking excessively</p> <p>d. Crossover relief valve set too low</p>	<p>i. Check base machine hydraulic system</p> <p>i. Check base machine hydraulic system</p> <p>i. Replace crossover relief valve</p> <p>i. Replace crossover relief valve</p>

INTERNAL ROTATION CONTROL SYSTEM TROUBLESHOOTING GUIDE

if equipped

The information contained in this guide provides for troubleshooting the Internal Rotation Control System only. Any references to the attachment or the base machine will be made only to give some guidance as to where a problem may exist. Any specific maintenance or troubleshooting information for the attachment or base machine will need to be obtained from its respective maintenance manual.

To properly troubleshoot the Hydraulic Rotation Circuit the following tools and equipment are needed:

- Hydraulic pressure gauge 0- 5000 PSI range
- Accumulator charge and test unit 0- 1000 PSI range
- Volt-Ohm meter
- Standard blade screwdriver
- Crescent wrench or similar tools for cover removal
- 3/16" Allen wrench
- Test light (optional)

SYMPTOM	PROBABLE CAUSE	REMEDY
1. Will not rotate	a. Faulty rotation motor b. No flow to rotation motor- no fluid in accumulator c. Faulty unloading valve d. Operating pressure is too low	i. Check motor per manual ii. Check for flow out of ports A & B ii. Check accumulator precharge pressure; should be 650 PSI. i. Check electrical power to the unloading valve. ii. Remove cartridge and check for contamination. i. Check pressure at the gauge "G" port, which should be 2000-2500 PSI; adjust pressure reducing valve if necessary.

MSD SABER SERIES SHEARS

INTERNAL ROTATION CONTROL SYSTEM TROUBLESHOOTING GUIDE

if equipped, continued

<i>SYMPTOM</i>	<i>PROBABLE CAUSE</i>	<i>REMEDY</i>
1. Will not rotate, continued	<p>e. Directional valve not operating</p> <ul style="list-style-type: none"> - spool sticking - faulty electrical signal - faulty valve solenoid coil <p>f. Flow control valve cartridge is faulty</p> <p>g. Accumulator does not charge with hydraulic fluid</p>	<p>i. Check electrical signal to valve coils. If the electrical signal is good, the coil is faulty and must be replaced.</p> <p>ii. Check continuity of valve coil.</p> <p>i. Remove, check for cartridge contamination.</p> <p>ii. Replace flow control valve.</p> <p>i. Unloading valve is faulty. Replace unloading valve.</p>
2. Rotation very slow	<p>a. Operating pressure is too low</p> <p>b. Flow control valve cartridge</p> <p>c. Faulty unloading valve</p> <p>d. Crossover relief bypassing oil</p> <p>e. Operating flow is too low</p>	<p>i. Check pressure at the gauge "G" port; this should be 2000-2500 PSI; adjust pressure reducing valve if necessary.</p> <p>i. Remove, check for contamination.</p> <p>ii. Replace flow control valve.</p> <p>i. Check electrical ground wire at the unloading valve.</p> <p>ii. Remove cartridge and check for contamination or seal damage.</p> <p>i. Replace crossover relief valve.</p> <p>i. Adjust shear flow control to increase flow to the rotation assembly.</p>

INTERNAL ROTATION CONTROL SYSTEM TROUBLESHOOTING GUIDE

if equipped, continued

<i>SYMPTOM</i>	<i>PROBABLE CAUSE</i>	<i>REMEDY</i>
2. Rotation very slow, continued	<p>f. Internal leakage of valve</p> <p>g. Hydraulic motor is faulty</p> <p>h. Supply flow too low</p>	<p>i. Remove unloading valve and relief valve cartridges in control valve cartridges; check for contamination or seal manifold damage.</p> <p>i. Rebuild or replace motor.</p> <p>i. Check base machine's hydraulic system.</p>
3. Rotation speed too fast	a. Operating flow too high	i. Adjust flow control to decrease flow from the accumulator.
4. Rotation is erratic	<p>a. Directional valve spool</p> <p>b. Faulty electrical signal at directional valve or unloading valve</p> <p>c. Flow control valve cartridge is faulty</p> <p>d. Faulty crossover relief on motor</p> <p>e. Faulty hydraulic motor</p> <p>a. Directional valve spool is sticking</p>	<p>i. Push in manual overrides alternately; then if sticking, try operating valve.</p> <p>i. Check electrical wiring, valve coil, electrical ground.</p> <p>i. Check for contamination or seal damage.</p> <p>i. Check shear manual</p> <p>i. Check shear manual</p> <p>i. Push in manual overrides alternately, then try operating valve.</p>

MSD SABER SERIES SHEARS

SPEED VALVE TROUBLESHOOTING GUIDE

There are two basic operating conditions of the speed valve that have a negative effect on shear performance and require troubleshooting and adjustment or repair. The first condition occurs when the speed valve does not seem to shift into the regenerative or speed mode, resulting in the shear closing slowly. The second condition occurs when the speed valve does not shift out of the speed mode at the appropriate time, resulting in a loss of shear cutting force. These conditions are referred to below with corrective actions listed to remedy the problem. For complete step-by-step instructions on adjusting the speed valve, please refer to page 4-37. If the problem still exists after attempting these adjustments, please contact your Stanley LaBounty dealer or the Stanley LaBounty Customer Service Department for further instructions.

The following tools and equipment are needed to properly troubleshoot and adjust the speed valve:

- pressure gauges- two are recommended so that two test ports can be checked simultaneously
- diagnostic test fittings and tools for installing the fittings
- a set of open or box end wrenches (12mm- 19mm)
- a set of Allen wrenches (4mm- 12 mm)

SYMPTOM	PROBABLE CAUSE	REMEDY
1. Shear does not shift consistently into speed mode when closing the jaw	a. Pilot pressure setting is too high	i. Adjust the pilot valve adjustment screw counterclockwise in increments of 1/8 of a turn (45°) until corrected.
2. Shear shifts into speed mode when jaw has been fully opened, but will not shift if jaws have only been opened partially	a. Too much back pressure in the base machine return line	i. Minimize back pressure if possible by using lines with larger diameters ii. If (i.) is not possible or does not completely solve the problem, adjust the main spool and then close adjustment screw clockwise in increments of 1/8 of a turn (45°) until corrected.
3. Shear jaw continues to close after the shear has shifted into speed mode and the operator has let go of the control	a. The main valve spool in the speed valve is not fully shifting out of speed mode	i. Adjust the main spool adjustment screw clockwise in increments of 1/8 of a turn (45°) until corrected.
4. Shear properly shifts into speed mode but seems to lack power	a. The main valve spool is not fully shifting out of speed mode	i. Adjust the pilot valve adjustment screw counterclockwise in increments of 1/8 of a turn (45°) until corrected.

LIMITED WARRANTY

NEW ATTACHMENT

Stanley LaBounty warrants its manufactured products against deficiency in material or workmanship for a period of 12 months from the date of first use, rental or sale, or 1500 hours of operation, whichever occurs first.

Limitations

- Remanufactured or used product or service repair are not warranted under this Limited Warranty.
- Product that is damaged by alteration, improper maintenance, unauthorized service, abuse, misuse, or contamination by the base machine is not warranted.
- This Limited Warranty is the exclusive warranty. Stanley LaBounty makes no representations, expressed or implied, of merchantability or fitness for a particular purpose.
- Agents of Stanley LaBounty have no authority to make representations beyond those contained herein.

Exclusive Remedy

The exclusive remedy for a product Stanley LaBounty determines deficient in material or workmanship is repair or replacement at Stanley LaBounty's option. The following procedure governs a repair or replacement warranty claim:

1. All warranty claims require a claim number provided by Stanley LaBounty Service Department.
2. A factory-issued Return Goods Authorization tag (RGA) must accompany returned product.
3. Returned product found deficient by Stanley LaBounty will be replaced or repaired without charge FOB Distributor/Customer or will be credited to account balance.
4. Authorized repair can occur at the Stanley LaBounty factory or authorized Stanley LaBounty Dealer. Labor for warranty repair will be paid under a formula determined by Stanley LaBounty.

Stanley LaBounty is not liable for incidental or consequential costs or losses incurred by the product, purchaser or user.

Limited Warranty

To validate the Limited Warranty, a completed warranty certificate and delivery inspection report must be returned to Stanley LaBounty. Prohibited operation and/or unauthorized adjustment or assembly will void this Limited Warranty. See the Operation, Maintenance and Safety Manual.

Contact Information

Contact your Stanley LaBounty Dealer or Stanley LaBounty regarding warranty questions. All requests for information, service or spare parts should include model and serial numbers. For the nearest Stanley LaBounty dealer contact:

Stanley LaBounty
1538 Highway 2
Two Harbors, MN 55616-8015 USA
Phone: (218) 834-2123 or (800) 522-5059
FAX: (218) 834-3879
E-mail: labounty@stanleyworks.com
Website: www.stanleyhydraulic.com



512141(ver 6/2012) The STANLEY and LABOUNTY names and logos are registered trademarks of Stanley Infrastructure Solutions