

STANLEY®

HSX SERIES MOUNTED HYDRAULIC COMPACTORS



HSX3



HSX6



HSX11



HSX22

USER MANUAL Safety, Operation and Maintenance



© 2015 STANLEY Black & Decker, Inc.
New Britain, CT 06053
U.S.A.
74918 11/2017 Ver. 7

DECLARATION OF CONFORMITY

DECLARATION OF CONFORMITY
ÜBEREINSTIMMUNGS-ERKLÄRUNG
DECLARATION DE CONFORMITE CEE
DECLARACION DE CONFORMIDAD
DICHIARAZIONE DI CONFORMITA

STANLEY
Hydraulic Tools
CE

I, the undersigned:
Ich, der Unterzeichnende:
Je soussigné:
El abajo firmante:
Io sottoscritto:

Weisbeck, Andy

Surname and First names/Familiennamen und Vornamen/Nom et prénom/Nombre y apellido/Cognome e nome

hereby declare that the equipment specified hereunder:
bestätige hiermit, daß erklaren Produkt genannten Werk oder Gerät:
déclare que l'équipement visé ci-dessous:
Por la presente declaro que el equipo se especifica a continuación:
Dichiaro che le apparecchiature specificate di seguito:

1. Category: **Hydraulic Powered Compaction Machine**
Kategorie:
Catégorie:
Categoria:
Categoria:
2. Make/Marke/Marque/Marca/Marca **Stanley**
3. Type/Typ/Type/Tipo/Tipo: **HSX3025S, HSX3125S, HSX6025S, HSX6125S, HSX11125S, HSX22125S**
4. Serial number of equipment:
Seriennummer des Geräts:
Numéro de série de l'équipement:
Numero de serie del equipo:
Matricola dell'attrezzatura:
5. Mass/Masse/Masse/Masa/Massa 168/998 kg

All

Has been manufactured in conformity with
Wurde hergestellt in Übereinstimmung mit
Est fabriqué conformément
Ha sido fabricado de acuerdo con
E' stata costruita in conformità con

Directive/Standards Richtlinie/Standards Directives/Normes Directriz/Los Normas Direttiva/Norme	No. Nr Numéro No n.	Approved body Prüfung durch Organisme agréé Aprobado Collaudato
EN ISO	12100:2010	Self
Machinery Directive	2006/42/EC:2006	

6. Special Provisions: **None**
Spezielle Bestimmungen:
Dispositions particulières:
Provisiones especiales:
Disposizioni speciali:
8. Representative in the Union: **Patrick Vervier, Stanley Dubuis 17-19, rue Jules Berthonneau-BP 3406 41034 Blois Cedex, France.**
Vertreter in der Union/Représentant dans l'union/Representante en la Union/Rappresentante presso l'Unione

Done at/Ort/Fait à/Dado en/Fatto a Stanley Hydraulic Tools, Milwaukie, Oregon USA Date/Datum/le/Fecha/Data 5-20-13

Signature/Unterschrift/Signature/Firma/Firma

Andy Weisbeck

Position/Position/Fonction/Cargo/Posizione Director of Product Development

Test Report #1252016HSX

TABLE OF CONTENTS

SAFETY SYMBOLS	4
SAFETY PRECAUTIONS.....	5
TOOL STICKERS & TAGS	6
OPERATION.....	7
TROUBLESHOOTING	10
FLOW TEST PROCEDURE	11
DEFINITION OF TERMS.....	13
SPECIFICATIONS.....	14
FLAT TOP MOUNTING DIRECTIONS	15
HSX3025S / HSX3125S PARTS LIST.....	16
HSX6025S / HSX6125S PARTS LIST.....	18
HSX11125S PARTS LIST.....	20
HSX22125S PARTS LIST.....	22
ATTACHMENT HOLE PATTERNS	24
NOTES.....	25

IMPORTANT

To fill out a product warranty validation form, and for information on your warranty, visit www.stanleyinfrastructure.com and select the Company tab > Warranty.

Note: The warranty validation record must be submitted to validate the warranty.

SERVICING: This manual contains safety, operation and routine maintenance instructions. STANLEY Infrastructure recommends that servicing of hydraulic tools, other than routine maintenance, must be performed by an authorized and certified dealer. Please read the following warning.

WARNING

SERIOUS INJURY OR DEATH COULD RESULT FROM THE IMPROPER REPAIR OR SERVICE OF THIS TOOL.

REPAIRS AND / OR SERVICE TO THIS TOOL MUST ONLY BE DONE BY AN AUTHORIZED AND CERTIFIED DEALER.

For the nearest certified dealer, call STANLEY Infrastructure at (503) 659-5660 and ask for a Customer Service Representative.

SAFETY PRECAUTIONS

- Tool operators and maintenance personnel must always comply with the safety precautions given in this manual and on the stickers and tags attached to the tool and hose.
- These safety precautions are given for your safety. Review them carefully before operating the tool and before performing general maintenance or repairs.
- Supervising personnel should develop additional precautions relating to the specific work area and local safety regulations. Place the added precautions in the space provided in this manual.
- This tool will provide safe and dependable service if operated in accordance with the instructions given in this manual. Read and understand this manual and any stickers and tags attached to the tool and hoses before operation. Failure to do so could result in personal injury or equipment damage.
- Check the rules and regulations at your location. The rules might include an employer's work safety program. Regulations may identify hazards such as working around utility supply lines or hazardous slopes.



BE THOROUGHLY TRAINED BEFORE OPERATING THE UNIT ALONE

- Operator training must start in an area without bystanders and use all the controls until he/she can control the machine fully under the conditions of the work area.
- When learning to operate a machine, do so at a slow pace.

KNOW THE WORK CONDITIONS

- The operator must know any prohibited uses or work areas for the machine. For example, excessive slopes and poor or dangerous terrain conditions must be avoided.

OBEY SAFETY RULES

- Replace all faulty or leaking hydraulic hoses or fittings before further operation.

- Always operate the compactor with backhoe outriggers firmly on the surface. The compactor weighs more than the bucket. Position the compactor with caution.
- Travel with the compactor in full tuck (transport) position only.
- Never operate with any person near the compactor or between the compactor and operator.
- Operate the compactor in properly shored trenches and excavations. Do not allow personnel to work in the excavation near compactor operation.
- Make sure all controls (levers and pedals) are in the NEUTRAL position before starting the carrier.
- Wear safety eye protection, hard hat and safety foot protection while operating the compactor.
- Operate the carrier or compactor from the operator's seat ONLY. Make sure the seat belt is securely fastened before activating any controls.
- Make certain that no other personnel are within the arc prescribed by the movement of the stabilizers, front bucket or backhoe boom.
- Keep hands and feet on the controls at all times when the machine is running.
- Before leaving the operator's seat, always lower the loader arms and the backhoe boom.
- NEVER leave the machine with the engine running. ALWAYS ENGAGE THE PARKING BRAKE.
- Stop the engine before attempting to make any repairs or adjustments to either the carrier or compactor.
- To avoid personal injury or equipment damage, all tool repair, maintenance and service must only be performed by authorized and properly trained personnel.

TOOL STICKERS & TAGS

ITEM NO.	DESCRIPTION	HSX3	HSX6	HSX11	HSX22
1	LIFT POINT DECAL	47352	47352	47352	47352
2	MADE IN TAIWAN DECAL	67373	67373	67373	66373
3	STANLEY DECAL	74707	74705	74705	74772
4	HSX MODEL DECAL	73092	73093	73094	73095
5	COMPOSITE WARNING DECAL	73119	73119	73119	73119
6	CE HSX DECAL	74739	74741	74742	74743

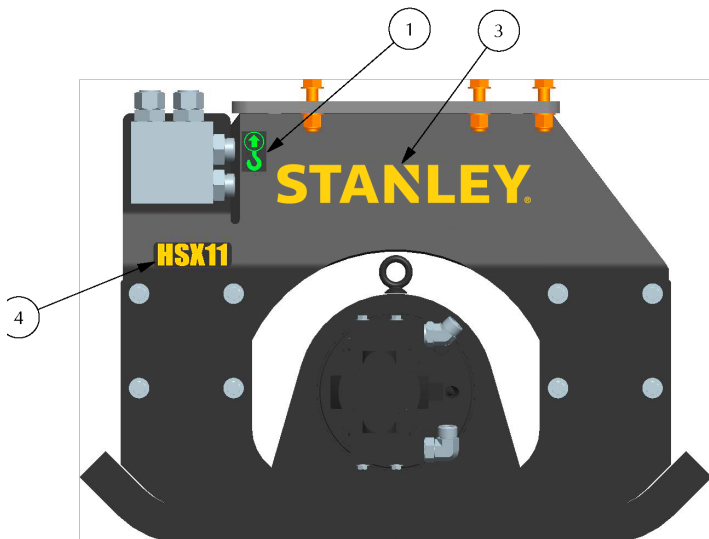
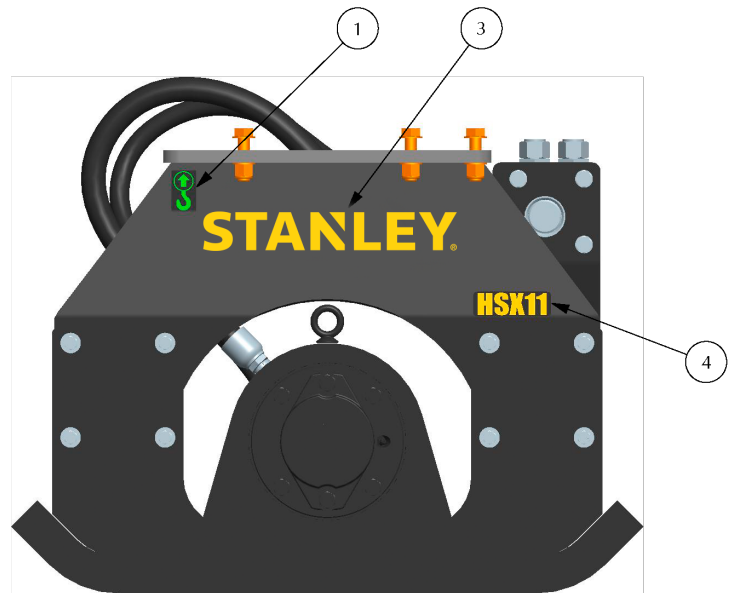
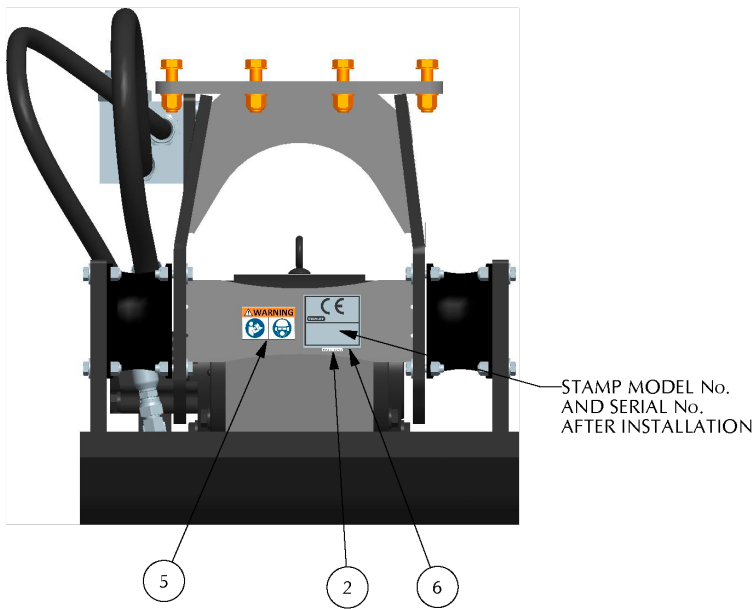

Lift Point Decal Location on Models HSX3025S & HSX6025S

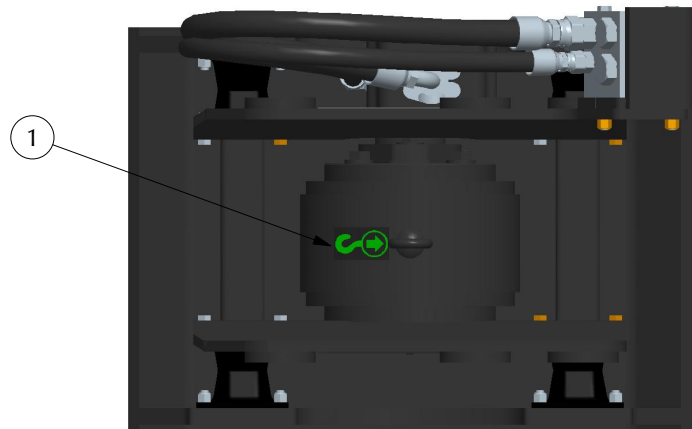

OPERATION

PRE-OPERATION PROCEDURES

DAILY MAINTENANCE CHECKS

Check for loose or missing fasteners. Tighten or replace as needed.

Check to be certain that the flow control valve on the carrier is set to the proper flow for the compactor. See the SPECIFICATIONS section of this manual.

Check shock mounts for cracks or tears. Rotate shock mounts 180° when fatigue tears begin to show at top outer crease of the shock mount. This will prolong the life of the shock mount.

Check for abrasion and hydraulic leaks at fittings and hoses. Replace defective hoses and fittings. Adjust hoses and tighten fittings so the hoses do not deflect into contact with structure during use.

DO NOT USE BARE HANDS TO CHECK OR SEARCH

WARNING

FOR HYDRAULIC LEAKS AROUND HOSES AND FITTINGS. PINHOLE LEAKS CAN PENETRATE THE SKIN. TO INSPECT FOR LEAKS, DEPRESSURIZE THE SYSTEM, CLEAN AROUND SUSPECTED AREA, REPRESSURIZE THE SYSTEM, AND VISUALLY CHECK FOR LEAKS.

Lubricate bearings with two pumps of grease every 40 hours of operation. A greasing location is provided in both bearing carriers.

Inspect pins and bushings for correct fit and lubrication.

Check level of hydraulic reservoir on carrier.

Make certain that quick couplers are fully engaged and leak free.

PRE-INSTALLATION INSTRUCTIONS

Test the carrier hydraulic system to verify that the system is operating at the manufacturer's specified capacity and pressure ratings.

Be sure the fluid and filter in the hydraulic system are clean.

When tightening pipe threads, be careful that any sealant used (Teflon® tape, etc.) does not enter the hydraulic system. Foreign matter introduced into the system may

damage hydraulic valves, motors and pumps.

Follow instructions to install the STANLEY priority valve in the carrier hydraulic system. The warranty is in effect only if the valve and compactor are installed as outlined in the valve kit installation instructions. Major modifications or equipment substitution will cause the warranty to be void unless prior engineering approval has been granted by STANLEY.

The STANLEY priority valve is a metering (to the hydraulic tool) pressure compensating valve that controls the flow to the attachment and gives the primary system (i.e. backhoe functions) full operating pressure. Diverter valves or simple flow control valves will not perform all of these required functions.

Note: On carriers where priority valves are not used, check with your local STANLEY distributor for an adapter kit to equip your carrier for a specific model of compactor.

LOW TEMPERATURE WARM-UP PROCEDURE

When the weather gets cold, the shock mounts on compactors can become stiff. In severe weather, where the ambient temperature is below freezing for extended periods, shock mounts can even become brittle. Therefore, it is necessary to warm the shock mounts prior to using the compactor. To warm the shock mounts follow these steps:

1. After starting the carrier, warm up the system until hydraulic lines are warm to the touch.
2. With the carrier at idle, place the compactor flat on the ground, and using a slight down pressure to keep the compactor in place, turn the compactor on. DO NOT place a load on the compactor during this procedure.
3. When the ambient temperature is below freezing, the compactor should be operated on the ground with a slight down pressure (no load) for at least one minute before putting it to work.

OPERATION

IMPORTANT

DO NOT suspend the compactor in the air during the warm-up procedure.

The compactor must be placed flat on the ground with a very slight down pressure to keep it in place. When ambient temperatures are below freezing, suspending the compactor in the air without first warming it up may cause the shock mounts to crack.

Failure to follow these procedures will void compactor shock mount warranty.

GENERAL INSTRUCTIONS

The compactor is a device that uses available force to the best advantage. The DYNAMIC FORCE of the mass weight assembly, turning at a high rpm, produces a vibratory force, and with controlled placement, an impact force. The DOWN PRESSURE of the carrier on the compactor gives a high static pressure which assists in the compaction or driving. The vibration frequency is controlled by the hydraulic flow input to the compactor and is optimized for use in granular soils. The rate and density of compaction depends on such factors as moisture content of the soil, condition of the compactor and carrier, and the skill of the operator.

NOTICE

Efficient compactor performance is directly related to the flow rate specified. A higher flow rate does not improve performance. It results in fluid overheating, and contributes to early bearing failure. A lower flow rate causes reduced compaction performance.

General Compaction

The following instructions are very important to the proper performance of the compactor and the attainment of the specified compaction density.

With a standard baseplate, the compactor is held with full down pressure for no more than 5-10 seconds. The application pattern should always begin next to a bank or

footing and at the previously compacted area. When the maximum attainable density for that particular soil condition is reached, a slight increase in vibration will be felt by the operator. This increase in vibration is in no way harmful to the tractor, and indicates that the soil will not compress any further. In fact, additional time in that location may actually loosen the soil previously compacted.

Work as much area as possible from one position and overlap each compacted section slightly. The vibration frequency has been chosen to give maximum efficiency in granular soils using lifts of 2 to 4 feet. The closer the width of the trench is to the width of the compactor, the higher the delivered compactive effort.

It is necessary to turn the compactor OFF when being transported or sitting idle. Should the running compactor be placed on a hard surface without down pressure, the unit and the carrier will vibrate excessively. Down pressure transmits the vibration to the soil; neutral pressure will rattle the whole carrier assembly.

Slope technique

This method of compaction is of primary interest to a pipeline contractor seeking high production and efficient equipment utilization. The fill material is placed at one end of the trench and allowed to seek its own angle of repose. Compaction is begun on this angle above, but still near, the top of the pipe. All fill material is backfilled to this angle and the compactor is worked up and down the slope. Backfilling, compaction, and resurfacing can be done very shortly after the pipe is in place.

Soil testing

Compaction density specifications are based on soil samples of a set moisture content and soil composition. Changing weather conditions, for example, can alter the moisture content of the fill being used, and may make meeting the specifications impossible. It is imperative that frequent and reliable tests be conducted during application of the compactor to determine the maximum lift that can be used and still provide the required density. It is important that lifts in excess of the established test results NOT be used if the required density is to be achieved and maintained.

Driving

Many driving jobs can be done with the compactor. Timber sheeting, steel and aluminum sheeting, H and I-beams, soldier piles and guard rail posts. The compactor will drive

OPERATION

these materials in most soil conditions, except solid rock or soil with a very high clay content.

The compactor is placed on the object to be driven using the front one-third of the baseplate (the portion of the baseplate furthest from the operator). This position is critical to proper delivery of the compactor's vibratory force into the object. The front portion of the compactor will impart an impact or "slap" that will drive the material into the soil. The center portion of the compactor will "rock" on the material and provide very little impact force.

Apply down pressure evenly, but do not compress the shock mounts fully. Too much down pressure will make the compactor difficult to control on top of the driven object, and the impact required will be damped out.

⚠ WARNING

SERIOUS INJURY OR DEATH COULD RESULT FROM ATTEMPTING to support the driven material.

PERSONNEL WHO ATTEMPT TO support the driven material CAN BE STRUCK OR CRUSHED.

Do not ATTEMPT to support the driven material.



One note of caution; the forces generated and the methods used while driving with a vibratory device preclude the calculation of "bearing loads" for a piling or sheet of material. **DO NOT USE THE COMPACTOR IN APPLICATIONS WHERE A BEARING LOAD IS SPECIFIED.**

TROUBLESHOOTING

If symptoms of poor performance develop, the following chart can be used as a guide to correct the problem.

PROBLEM	CAUSE	SOLUTION
Compactor Inoperative.	System Flow Valve not operating or adjusted incorrectly.	Adjust flow for compactor; flow and pressure test attachment circuit or compactor flow control, if installed.
	Seized bearings.	Replace bearings and perform flow and pressure tests.
	Kinked hose.	Replace.
	Plugged quick-disconnect	Repair or replace.
Rapid bearing failure.	Lack of lubrication.	Lubricate both bearings every 40 hours.
	Overspeeding.	Adjust flow for compactor; flow and pressure test attachment circuit or compactor flow control, if installed.
Rapid shock mount failure.	Excessive down pressure or carrier too large for compactor.	Compress shock mounts no more than 2-2.5 in./51-64 mm during operation.
	Cold weather operation.	Warm up according to Low-Temperature Warmup procedure.
Failure to achieve required compaction specifications.	Improper use.	See Operation section of this manual.
	Overspeeding or underspeeding of compactor.	Adjust flow for compactor; flow and pressure test attachment circuit or compactor flow control, if installed.
	Moisture/soil content incorrect for specified density..	Correct condition of soil, or compactor specifications are not reasonable for conditions.

FLOW TEST PROCEDURE

The correct performance of this procedure will verify if the auxiliary circuit of the carrier is adequate to properly operate a STANLEY attachment.

This procedure is generic in form. It is the end users responsibility to ensure that this procedure will work with their specific type of equipment.

If an adequate flow meter is not available, contact your STANLEY distributor for assistance.

Test Procedure

1. With the auxiliary circuit (or kit) completely installed connect the flow meter between the tool inlet and outlet hoses.

Note: Always use the hoses that are supplied for the attachment and make sure the machine hydraulic oil is between 90° to 120° F. This will assure correct readings and adjustments.

2. With the machine setting at the mode that's going to be used to operate the attachment, record the GPM _____.

Locate the correct flow for the attachment in the manual under the specification section. Adjust the machine to the correct GPM.

Note: If possible, always set the machine to the highest GPM output mode. This will prevent the operator from over flowing the attachments.

3. Once the correct GPM flow is achieved fully open the restrictor on the flow meter.
4. With the machine in the attachment mode set in step 2 ,record the back pressure. At this point the pressure reading on the pressure gauge is the back-pressure in the circuit. This pressure must not exceed 200 psi/13.5 bar.

Excessive back-pressure will slow the attachments operation and lead to premature seal failures and over heating.

Record the back-pressure _____ psi.

5. Close the restrictor valve on the flow meter until the attachment relief starts to crack or open. The relief valve opens when the flow rate (GPM), indicated on the flow meter begins to decline rapidly. Locate the tools operating system relief pressure in the specification section in the manual. Adjust attachment relief to specification.

Note: The relief valve pressure must be greater than the operating pressure of the attachment and three times the back-pressure. Never use the relief valve to control the flow rate in the circuit. Cracking pressure means the loss of 4 or more GPM.

Record the relief cracking pressure _____ psi.

Example:

Operation pressure of a breaker is 2700 psi. Back pressure is 150 psi. A good rule to follow when setting the relief is to multiply the back pressure by 3 then add this number to the operation pressure of the attachment.

Operating Pressure	2700 psi
Back-pressure	450 psi
Operating pressure of the tool	3150 psi

The relief valve setting must be greater than the estimated operating pressure of the tool. If the setting is lower, damage to the circuit may occur. Excess heat will be generated in the circuit which will damage the attachment and carrier.

Heat Load Test

With the installation kit properly installed and adjusted, per the above procedure, conduct the head load test as follows.

1. Connect the flow meter between the tool inlet and outlet hoses.
2. With the carrier set in the attachment mode, restrict the flow meter until a pressure of 1000 psi is achieved. This pressure must be maintained throughout the heat test.

Note: Closing of the restrictor may be required as the temperature increases.

Monitor the oil temperature from the flow meter until no change is noted. Record the time required for oil to stabilize. Record the surrounding temperature (ambient temperature). Record the time required to stabilize _____ minutes.

Record the stabilized oil temperature _____ F.

Record the ambient temperature _____ F.

The "heat rise" is calculated as the stabilized temperature minus the ambient temperature.

FLOW TEST PROCEDURE

Example:

Stabilized Temperature	160°
Ambient Temperature	-80°
Heat Rise	80°

The normal operating temperature range of this circuit will be the typical ambient temperature range for the geographical area plus the heat rise calculated above. Ensure that the operating temperature range is lower than 180° for optimum operation of the attachment.

Troubleshooting

If adequate pump flow is available from the carrier pump(s) but is not getting to the attachment, consult your service representative and review the following:

1. Attachment valve(s) are not actuating. Review all electrical connections that are part of the attachment kit.
2. Ensure proper voltage to the valve(s).
3. Ensure the REG port of the valve is not blocked.
4. Check to make sure the carriers main relief is set to the manufacturers recommendation and that this value is equal or greater than the attachment circuit relief.
5. If the valve will not turn off, check the drain (tank) line of the valve to ensure that the pressure is 50 psi or less.

DEFINITION OF TERMS

Tool: The hydraulic attachment which the auxiliary circuit is intended to power. These may include hydraulic breakers, compactors, shears, etc.

Operating Pressure: That pressure at which the tool will naturally operate without influence from outside pressure relief mechanisms. This pressure is an operating characteristic of the tool and cannot be altered by the end user.

Relief Pressure: The relief pressure is that pressure at which the circuit will dump fluid in order to protect itself from damage.

Back Pressure: The pressure at the tool's connection to the return circuit of the carrier.

Flow Meter: Instrument for testing the operating characteristics of a hydraulic circuit. The data available from this device are pressure (psi/bar), flow (gpm/lpm) and temperature (°F/°C).

Restrictor Valve: A valve on the flow meter which allows the user to simulate an operating tool by adding a pressure load (through restriction) to the circuit. This feature is used to evaluate relief settings and flow ratings at pressure.

V60/V65/V100 Valves: A priority flow control valve manufactured by STANLEY. Allows for optimum operation of any attachment by providing the proper amount of flow for operation of the tool. The "priority" aspect allows the attachment to function properly if another control function is activated.

Inlet Flow: The hydraulic oil supplied to the "IN" port of the tool or valve.

Regulated Flow: The flow of oil supplied to the tool by the V60/V100 valve.

By-Pass Flow: The oil flow that is supplied by the carriers pump, but not used in the operation of the attachment. By-pass flow equals inlet flow (to the valve) minus the regulated flow.

Pressure Line: The hydraulic line(s) which supply pressurized oil from the pump to the valve or tool.

Return Line: The hydraulic line which connects the "OUT" port of the tool to the tank circuit of the carrier.

Cracking Pressure: The pressure at which the relief valve starts to open. Can be seen by a drop in the flow rate as shown by the flow meter.

Full Open Pressure: The pressure at which the relief valve is completely open, dumping all system flow to the tank.

Ambient Air Temperature: The temperature of the outside air.

Stabilized Temperature: The temperature at which the carrier hydraulic system temperature will stop rising during testing or operation.

SPECIFICATIONS

		HSX3	HSX6	HSX11	HSX22
Centrifugal Force	lbs	3400	6400	11,350	22,000
	kg	1542	2902	5147	10,000
Vibrations Per Minute	vpm	2100	2000	2000	2100
Weight	lbs	370	850	1425	2200
	kg	168	386	646	998
Length	in	25.5	34	35	45
	mm	650	860	889	1143
Width	in	17.5	23.5	27	32
	mm	445	600	686	813
Height	in	18.5	27.5	29	41.25
	mm	470	700	737	1048
Baseplate Size	in	18.8 x 20	23.5 x 26	27 x 30	32 x 42
	mm	442 x 508	600 x 660	686 x 762	813 x 1067
Hydraulic Pressure	psi	1600-2000	1800-2000	1800-2150	1800-2250
	bar	110-140	127-140	124-148	124-155
Flow Range	gpm	12-25	12-25	28-60	42-70
	lpm	45-95	45-95	106-227	159-265
Optimum Flow	gpm	13	13	30	45
	lpm	49	49	113	170
System Relief	psi	2500	2500	2500	2500
	bar	172	172	172	172
Back Pressure (max)	psi	250	250	250	250
	bar	17	17	17	17

Miscellaneous Flow Meter.....29085

Note: Torque values for a particular model can be found on the exploded views (pages 16 through 23). Look for the picture of the part (or fastener) you are trying to torque. The torque value is next to the item number of the part.

MAINTENANCE INTERVALS

SERVICE ITEM
10 HOUR / Daily Service
Check for Loose or Missing Fasteners
Check Shock Mounts
40 Hour / Weekly Service
Perform All Daily Service Checks
Lubricate Each Bearing with 2 Pumps of Grease Every 40 Hours of Operation

Note: Weights, dimensions and operating specifications listed on this sheet are subject to change without notice. Where specifications are critical to your application, please consult the dealer.

FLAT TOP MOUNTING DIRECTIONS

HSX3125S TOP PLATE MOUNTING DIMENSIONS

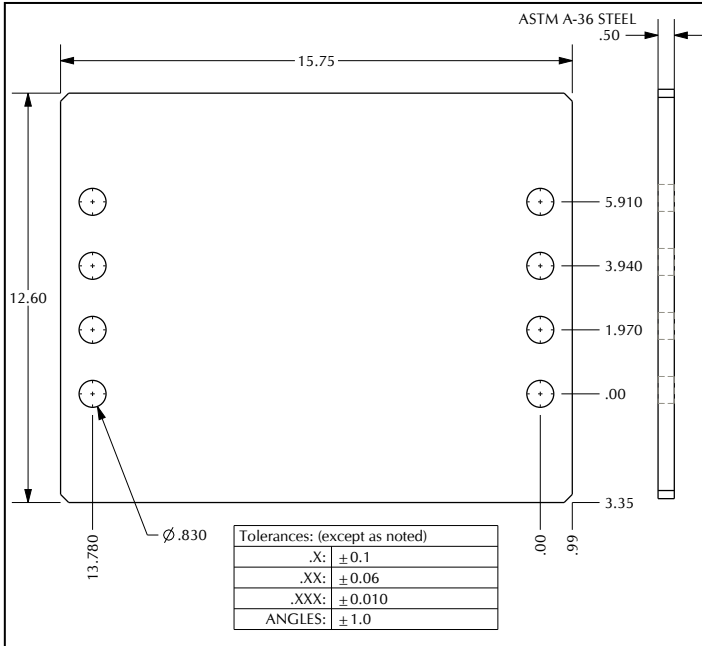

HSX6125S TOP PLATE MOUNTING DIMENSIONS

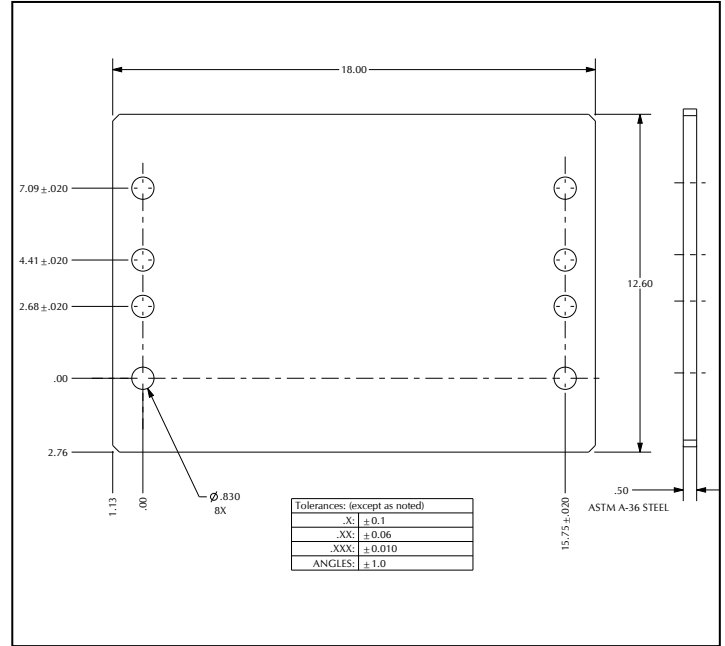

HSX11125S TOP PLATE MOUNTING DIMENSIONS

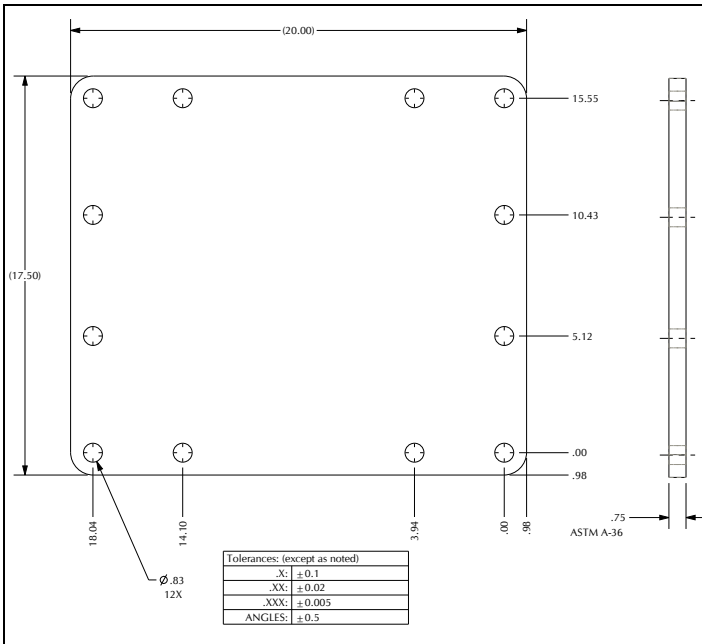

HSX22125S TOP PLATE MOUNTING DIMENSIONS

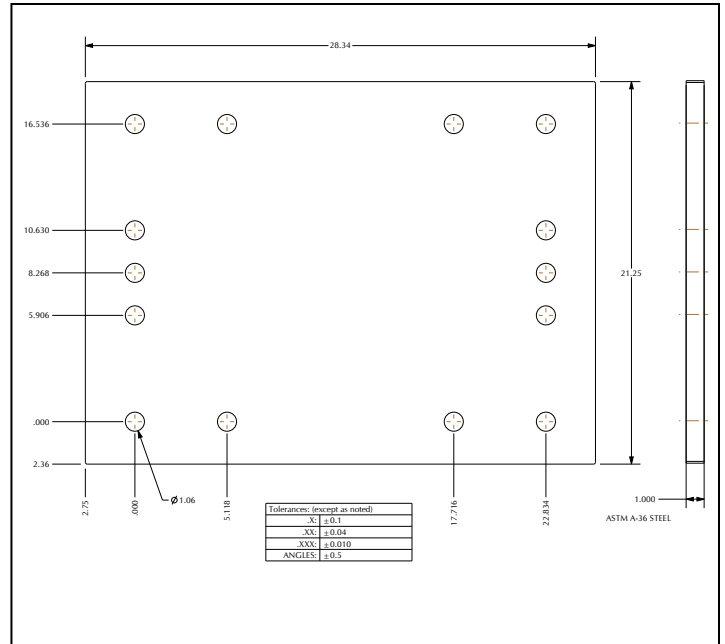

HSX3025S / HSX3125S PARTS LIST

Note: The HSX3025S and HSX3125S use the same parts shown on this page, with the exception of the upper frame weldment and fasteners shown at right. Items at right are for the HSX3125S only.

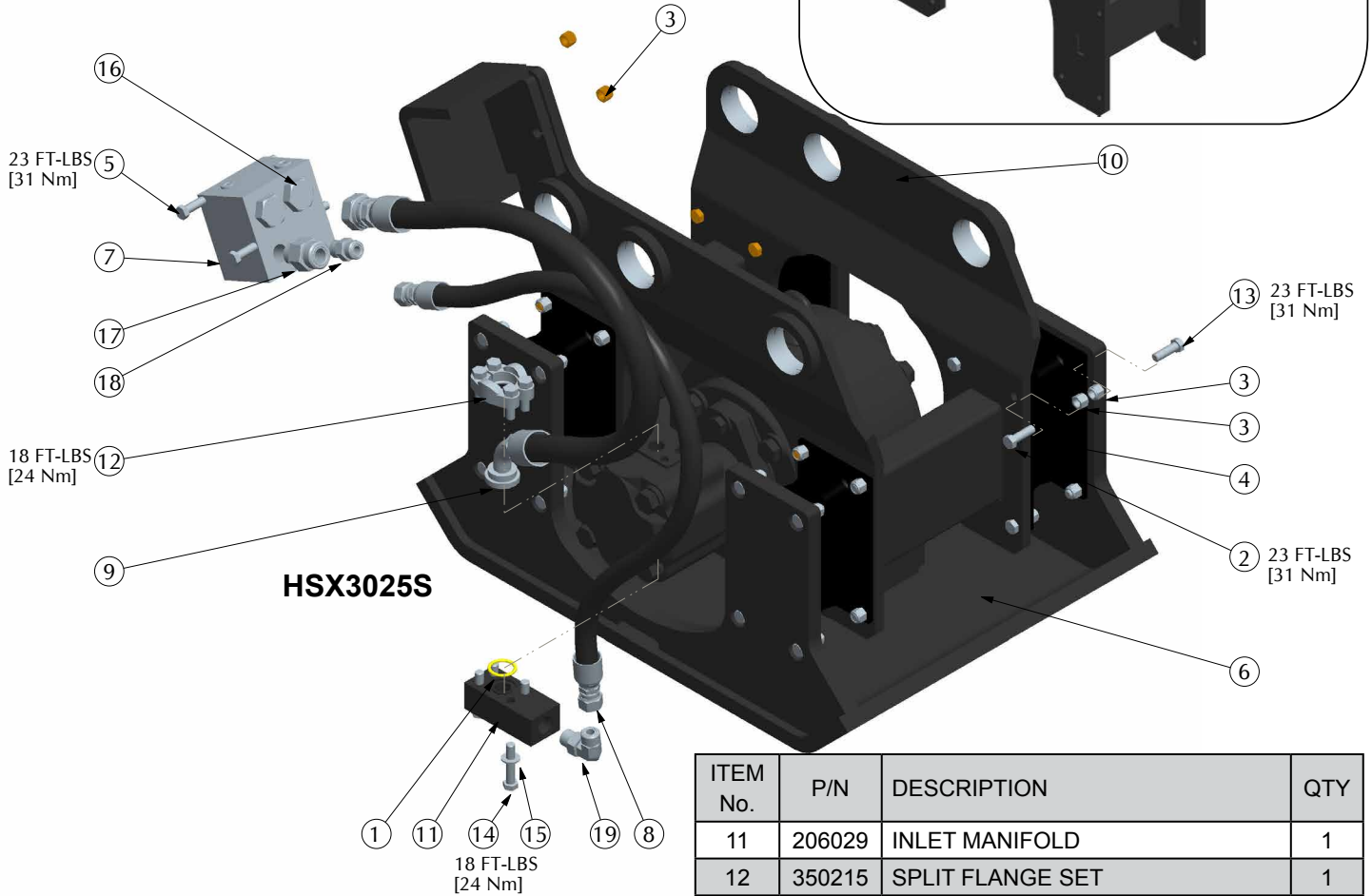
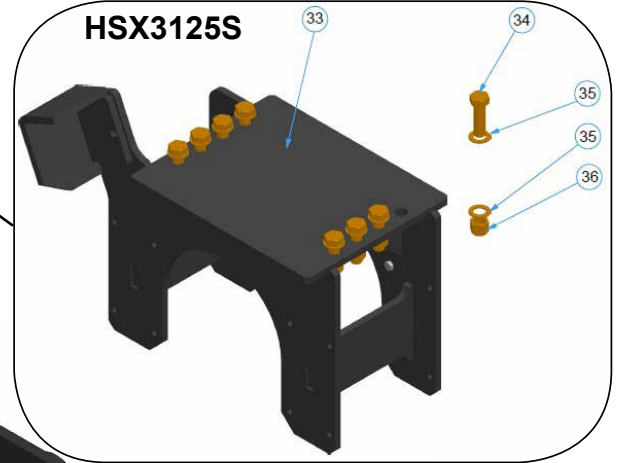

ITEM No.	P/N	DESCRIPTION	QTY
11	206029	INLET MANIFOLD	1
12	350215	SPLIT FLANGE SET	1
13	370152	HHCS 3/8-16UNC X 1.250	16
14	370155	HHCS 3/8-16UNC X 2.000	4
15	371056	WASHER 3/8" I.D.	4
16	501888	PLUG HEX SAE-12 ORB	2
17	514012	HYD ADAPTER 10SAE-12ORS	1
18	514013	HYD ADAPTER 8SAE-8ORS	1
19	514014	HYD ADAPTER 8SAE-8ORS-90	1
	67936	MOTOR SEAL KIT	1

HSX3125S ONLY			
33	72716	UPPER FRAME WELDMENT	1
34	72876	HHCS 3/4-10UNCx2.50	8
35	43533	WASHER	16
36	371501	NYLOCK NUT 3/4-10UNC	8

ITEM No.	P/N	DESCRIPTION	QTY
1	00834	O-RING 1 X 1-1/4 X 1/8 -214	1
2	02099	HHCS 3/8-16UNC X 1.250	16
3	04353	NYLOCK NUT 3/8-16UNC	34
4	12079	SHOCK MOUNT	4
5	27619	HHCS 3/8-16UNC X 5.5000	2
6	35245	SHOE WELDMENT	1
7	72708	FLOW CONTROL VALVE	1
8	72722	ASSY HOSE	1
9	72723	ASSY HOSE	1
10	73122	UPPER FRAME WELDMENT	1

HSX3025S / HSX3125S PARTS LIST

Note: The HSX3025S and HSX3125S use the same parts shown on this page. The differences between the two models are the upper frame weldment and the fasteners that come with it (see page 16 for details).

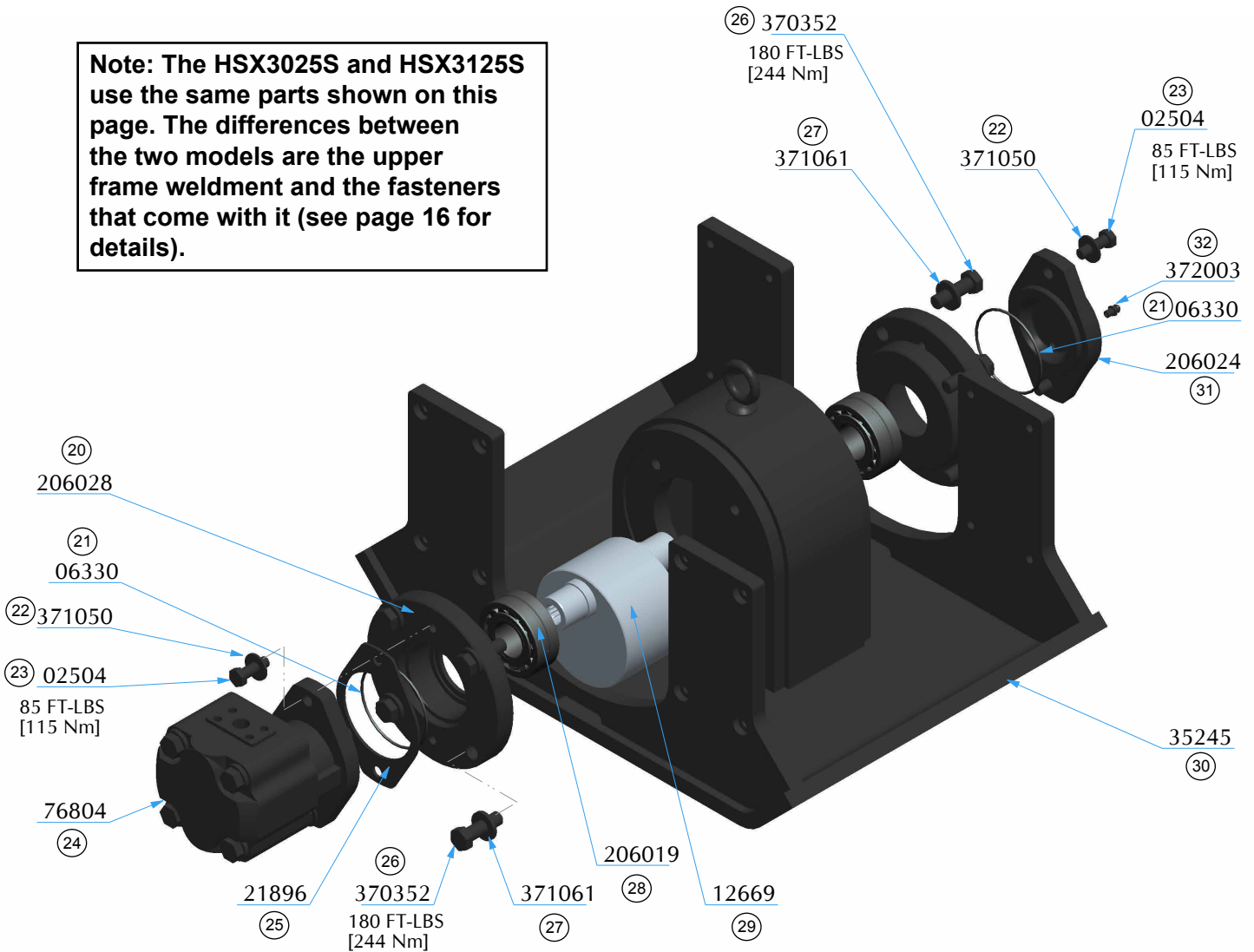

ITEM No.	P/N	DESCRIPTION	QTY
20	206028	BEARING CARRIER	2
21	06330	O-RING	2
22	371050	WASHER	4
23	02504	HHCS 1/2-13UNCx1-1/2	4
24	76804	MOTOR	1
25	21896	MOUNT ADAPTOR	1
26	370352	HHCS 5/8-11UNCx2	8
27	371061	WASHER	8
28	206019	BEARING	2
29	12669	MASS WEIGHT ASSY HSX3	1

ITEM No.	P/N	DESCRIPTION	QTY
30	35245	SHOE WELDMENT	1
31	206024	BEARING COVER	1
32	372003	GREASE FITTING	1
	67936	MOTOR SEAL KIT	1

HSX6025S / HSX6125S PARTS LIST

Note: The HSX6025S and HSX6125S use the same parts shown on this page, with the exception of the upper frame weldment and fasteners shown at right. Items at right are for the HSX6125S only.

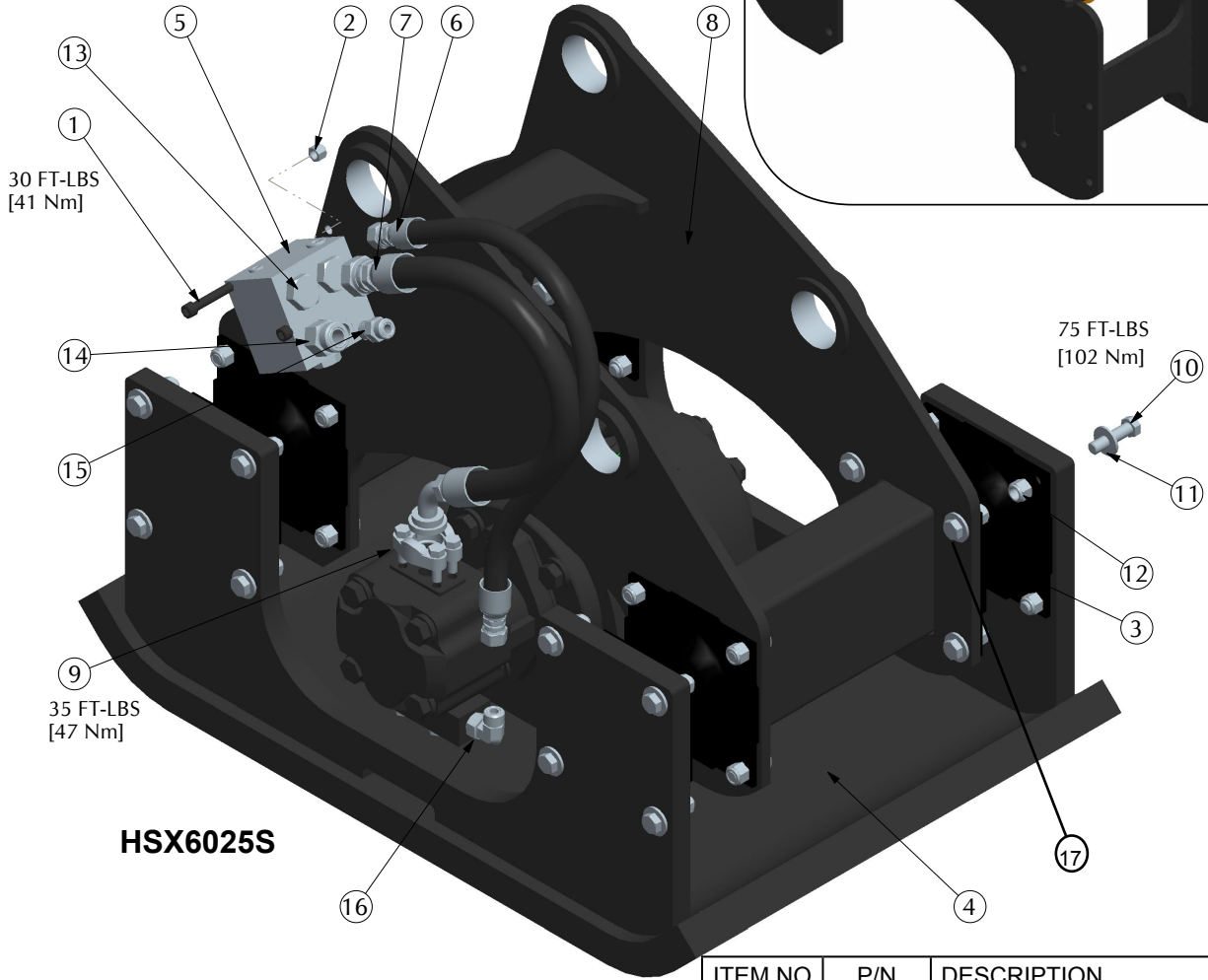
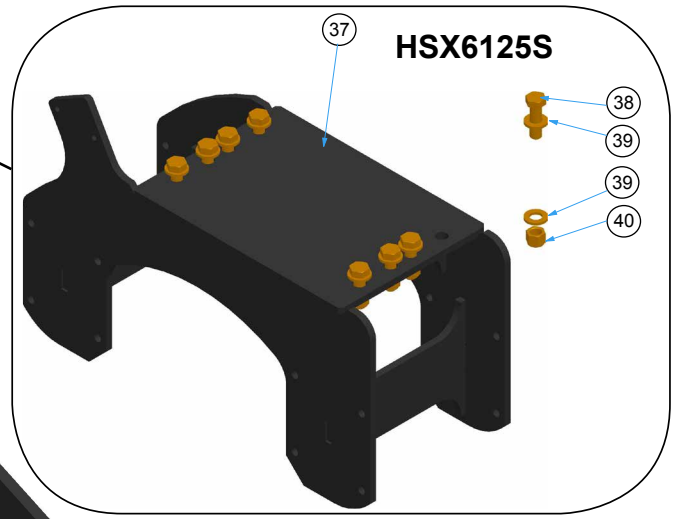

HSX6025S

ITEM NO	P/N	DESCRIPTION	QTY
1	02555	HSHCS 3/8-16 X 5.000	2
2	04353	NYLOCK NUT 3/8-16UNC	2
3	74844	SHOCK MOUNT	4
4	33688	SHOE WELDMENT	1
5	72708	FLOW CONTROL VALVE	1
6	72709	ASSY HOSE	1
7	72710	ASSY HOSE	1
8	73125	UPPER FRAME WELDMENT	1
9	350215	SPLIT FLANGE SET	1
10	370252	HHCS 1/2-13UNC X 2.000	16
11	371050	WASHER 1/2" I.D.	36

ITEM NO	P/N	DESCRIPTION	QTY
12	371500	NYLOCK NUT 1/2-13UNC	32
13	501888	PLUG HEX SAE-12 ORB	2
14	514012	HYD ADAPTER	1
15	514013	HYD ADAPTER	1
16	514014	HYD ADAPTER	1
17	370250	HHCS 1/2-13UNC X 1.500	16
	67936	MOTOR SEAL KIT	1

HSX6125S ONLY			
37	72705	UPPER FRAME WELDMENT	1
38	72876	HHCS 3/4-10UNC x 2.50	8
39	371052	WASHER 3/4 ID	16
40	371501	NYLOCK NUT 3/4-10	8

HSX6025S / HSX6125S PARTS LIST

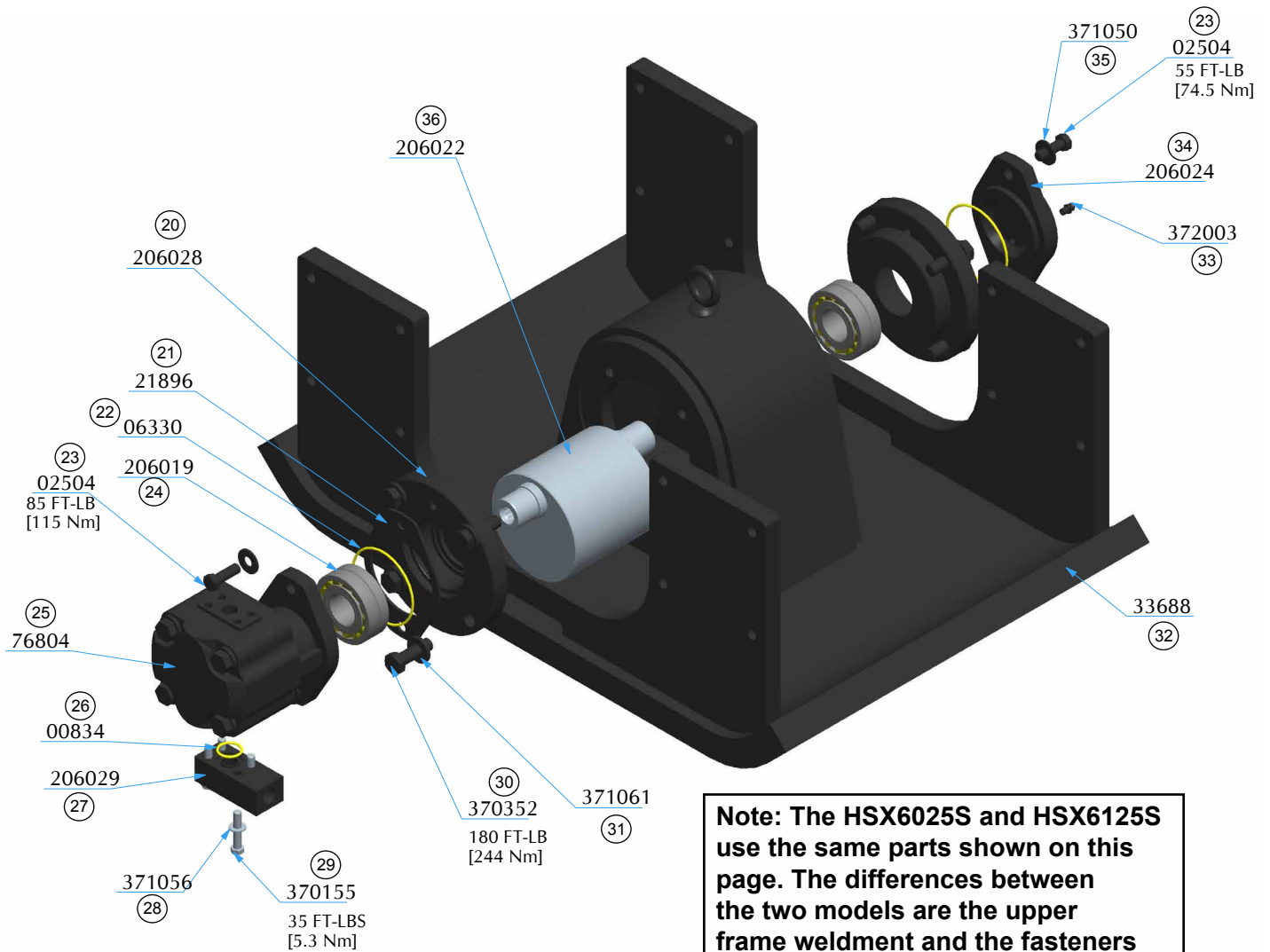

Note: The HSX6025S and HSX6125S use the same parts shown on this page. The differences between the two models are the upper frame weldment and the fasteners that come with it (see page 18 for details).

ITEM No.	P/N	DESCRIPTION	QTY
20	206028	BEARING CARRIER	2
21	21896	MOUNT ADAPTOR	1
22	06330	O-RING	2
23	02504	HHCS 1/2-13UNCx1-1/2	4
24	206019	BEARING	2
25	76804	MOTOR	1
26	00834	O-RING	1
27	206029	INLET MANIFOLD	1
28	371056	WASHER	4
29	370155	HHCS 3/8-16UNCx2	4

ITEM No.	P/N	DESCRIPTION	QTY
30	370352	HHCS 5/8-11UNCx2	8
31	371061	WASHER	8
32	33688	SHOE WELDMENT HSX6	1
33	372003	GREASE FITTING	1
34	206024	BEARING COVER	1
35	371050	WASHER	36
36	206022	MASS WEIGHT HSX6	1
	67936	MOTOR SEAL KIT	1

HSX11125S PARTS LIST

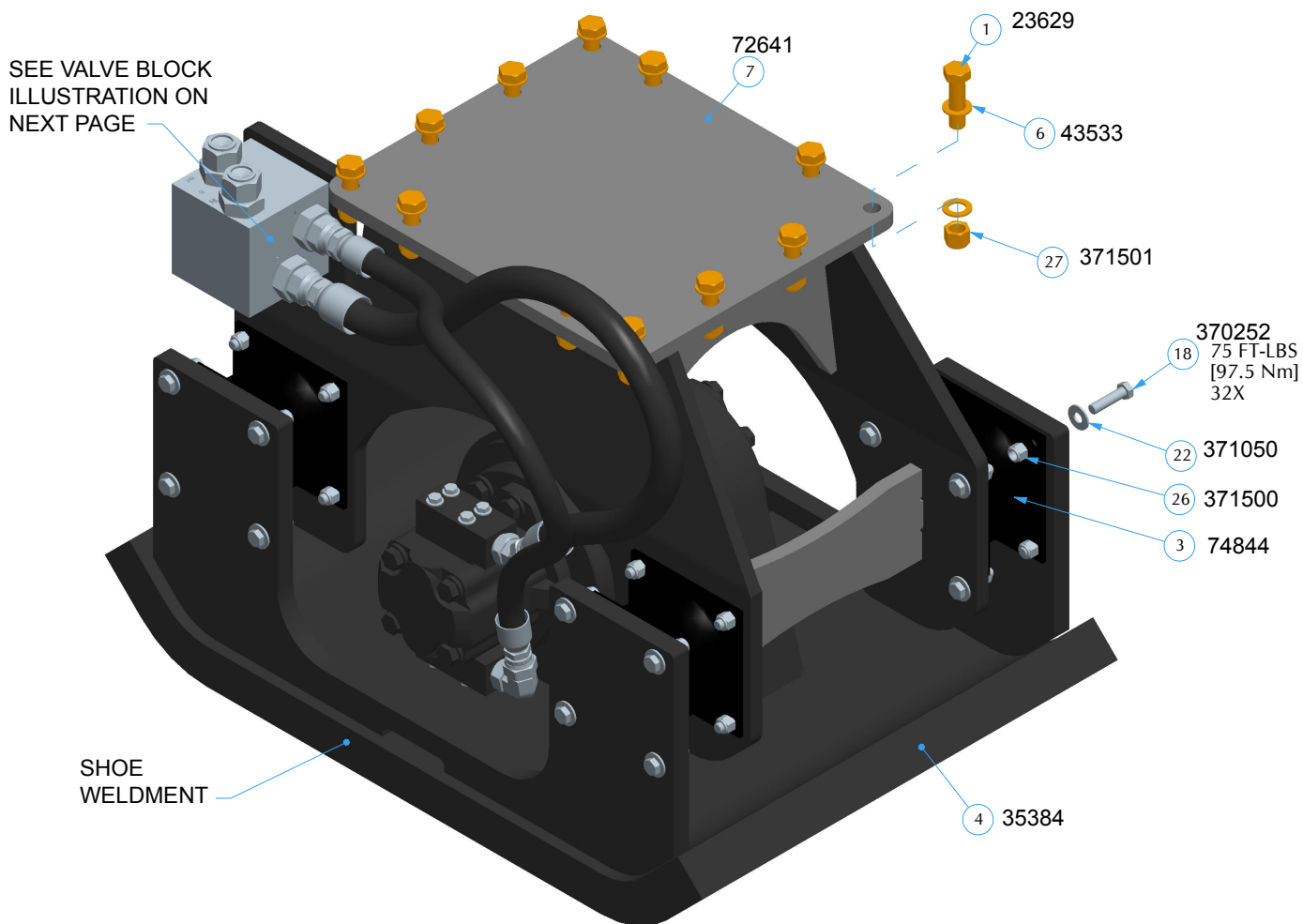

ITEM NO.	P/N	DESCRIPTION	QTY
1	23629	HHCS 3/4-10UNC X 2.750	12
2	29935	OUTLET MANIFOLD	2
3	74844	SHOCK MOUNT	4
4	35384	SHOE WELDMENT	1
5	76805	HYDRAULIC MOTOR	1
6	43533	WASHER 3/4" I.D.	24
7	72641	UPPER FRAME WELDMENT	1
8	72650	HOSE ASSY	1
9	72651	HOSE ASSY	1
10	72754	FLOW CONTROL 30GPM	1
11	211008	MASS WEIGHT ASSEMBLY	1
12	211009	LS BEARING CARRIER	2
13	211011	L.S. BEARING COVER	1
14	217010	BEARING	2
15	350713	O-RING	2
16	350758	O-RING	2

ITEM NO.	P/N	DESCRIPTION	QTY
17	370159	HHCS 3/8-16UNC X 2.500	8
18	370252	HHCS 1/2-13UNC X 2.000	32
19	370350	HHCS 5/8-11UNC X 1.750	2
20	370351	HHCS 5/8-11UNC X 1.750	6
21	370353	HHCS 5/8-11UNC X 2.250	8
22	371050	WASHER 1/2" I.D.	32
23	371056	WASHER 3/8" I.D.	8
24	371061	WASHER 5/8" I.D.	12
25	371071	LOCKWASHER 5/8" I.D.	4
26	371500	NYLOCK NUT 1/2-13UNC	32
27	371501	NYLOCK NUT 3/4-10UNC	12
28	372003	GREASE FITTING, 1/8 NPT	2
29	514010	HYD ADAPTER -20SAE	4
30	514015	HYD ADPT -12SAE	1
31	514016	HYD ADPT -12SAE	1
32	514017	HYD ADAPTER -CAP	2
	67935	MOTOR SEAL KIT	1

HSX11125S PARTS LIST

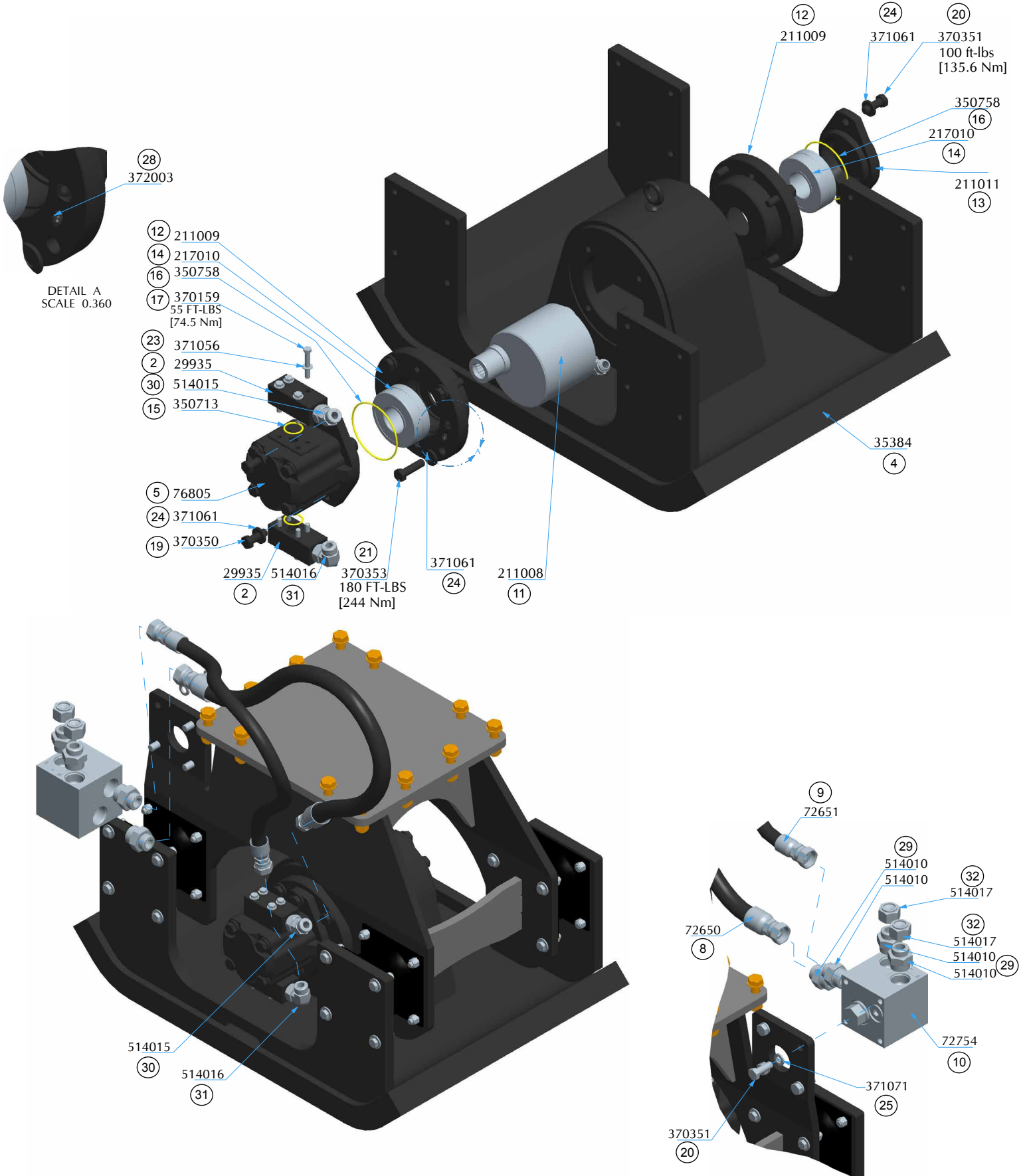

HSX22125S PARTS LIST

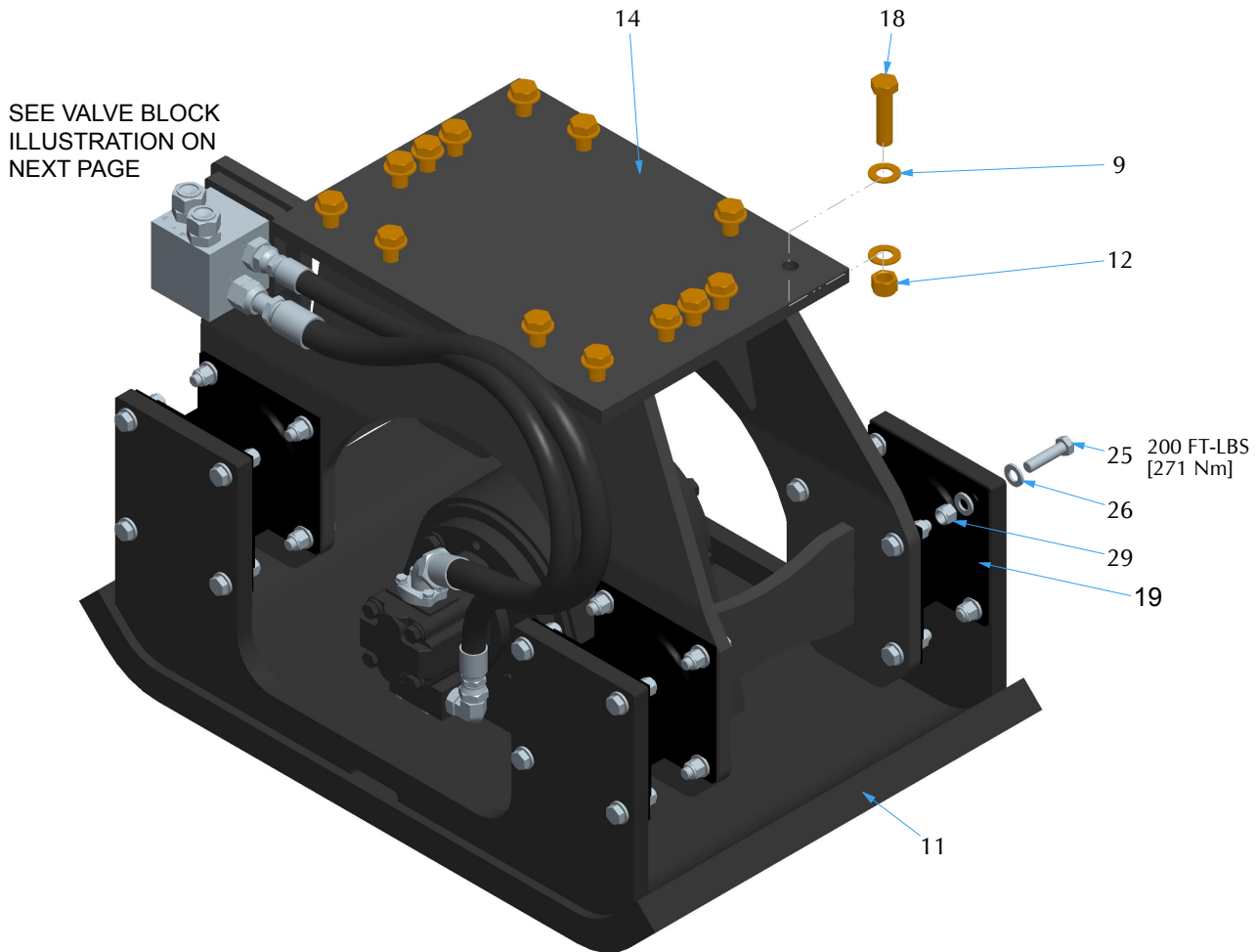

ITEM	PART NO.	DESCRIPTION	QTY
1	350609	SPLIT FLANGE HALF	1
2	22568	PILOT RING	1
3	22572	BEARING CARRIER	2
4	22606	MASS WEIGHT ASSEMBLY	1
5	22607	BEARING COVER	1
6	22608	BEARING	2
7	76797	MOTOR MODIFIED	1
8	22860	HHCS 7/16-14UNC X 2.750	4
9	23750	WASHER 1" I.D.	28
10	30269	O-RING	2
11	35653	SHOE WELDMENT	1
12	44956	NYLOCK NUT 1-8UNC	14
13	370360	HHCS 5/8-11UNC X 3.000	4
14	72630	UPPER FRAME WELDT	1
15	72636	ASSY HOSE	1
16	72637	ASSY HOSE	1
17	72826	FLOW CONTROL VALVE 42GPM	1

ITEM	PART NO.	DESCRIPTION	QTY
18	72875	HHCS 1-8UNC X 4.00	14
19	217005	SHOCK MOUNT CD-2000	4
20	217012	INLET MANIFOLD	1
21	350759	O-RING	2
22	370405	HHCS 3/4-10UNC X 2.250	2
23	370406	HHCS 3/4-10UNC X 2.500	8
24	370407	HHCS 3/4-10UNC X 2.000	2
25	370409	HHCS 3/4-10UNC X 3.000	32
26	371052	WASHER 3/4" I.D.	76
27	371061	WASHER 5/8" I.D.	4
28	371063	WASHER 7/16" I.D.	4
29	371501	NYLOCK NUT 3/4-10UNC	32
30	372003	GREASE FITTING, 1/8 NPT	2
31	514009	HYD ADAPTER -16SAE-16ORS-90	1
32	514010	HYD ADAPTER -20SAE-16ORS	1
33	514011	ADAPTER 20F5OLO-2	3
34	514018	ADAPTER CAP	2
	67935	MOTOR SEAL KIT	1

HSX22125S PARTS LIST

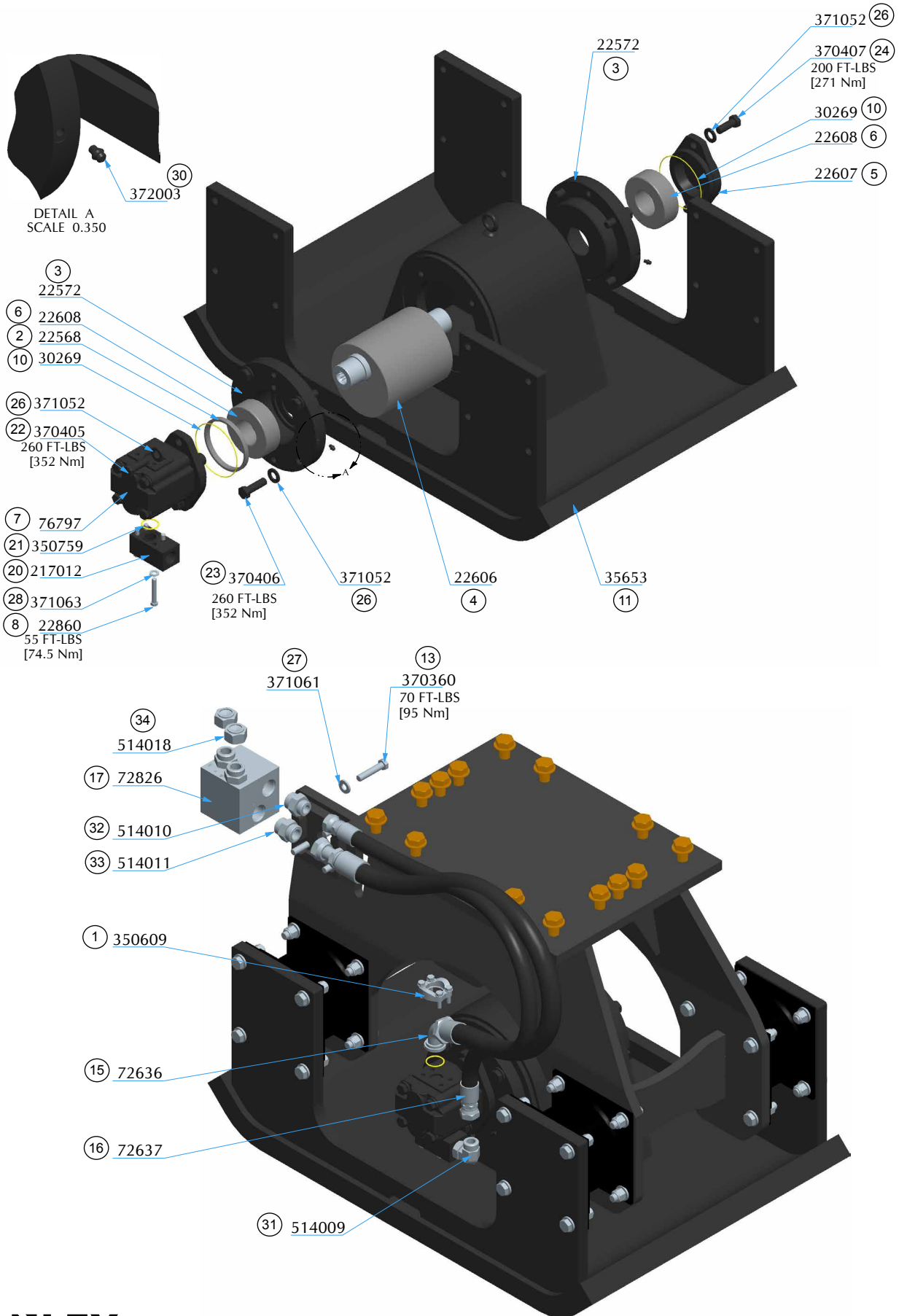

ATTACHMENT HOLE PATTERNS

HSX3, HXS6 & HSX11 WITH HOLE PATTERN CENTERED ON SHOE WELDMENT

Hole patterns shown below for pile-driving attachments.

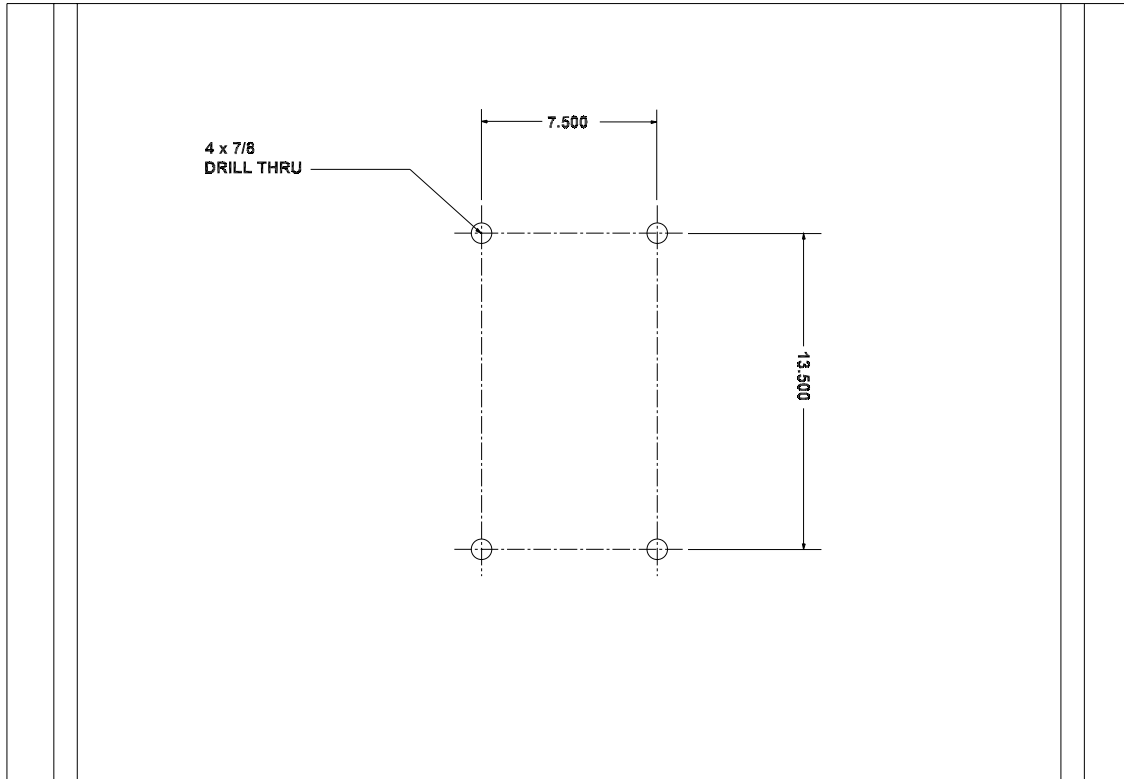

HSX22 WITH HOLE PATTERN CENTERED ON SHOE WELDMENT

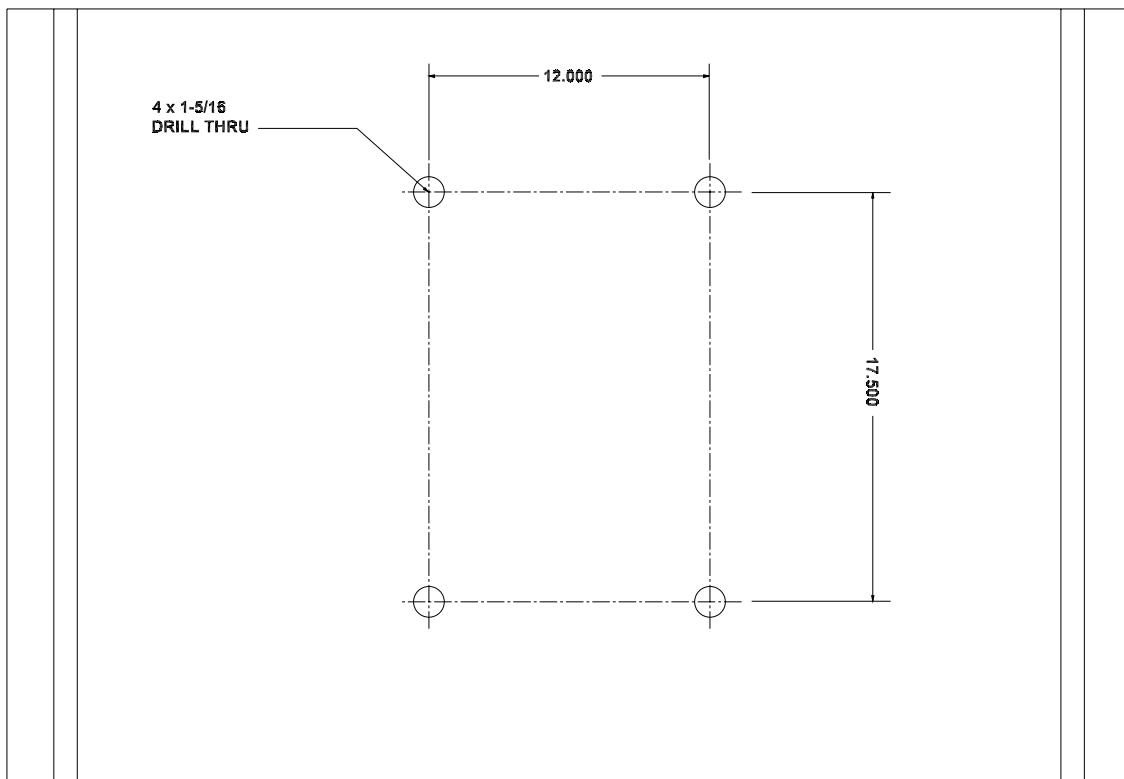

STANLEY®

STANLEY Infrastructure
3810 SE Naef Road
Milwaukie, Oregon 97267-5698 USA
(503) 659-5660 / Fax (503) 652-1780
www.stanleyinfrastructure.com